

STREET DESIGN MANUAL FOR URBAN AREAS IN KENYA

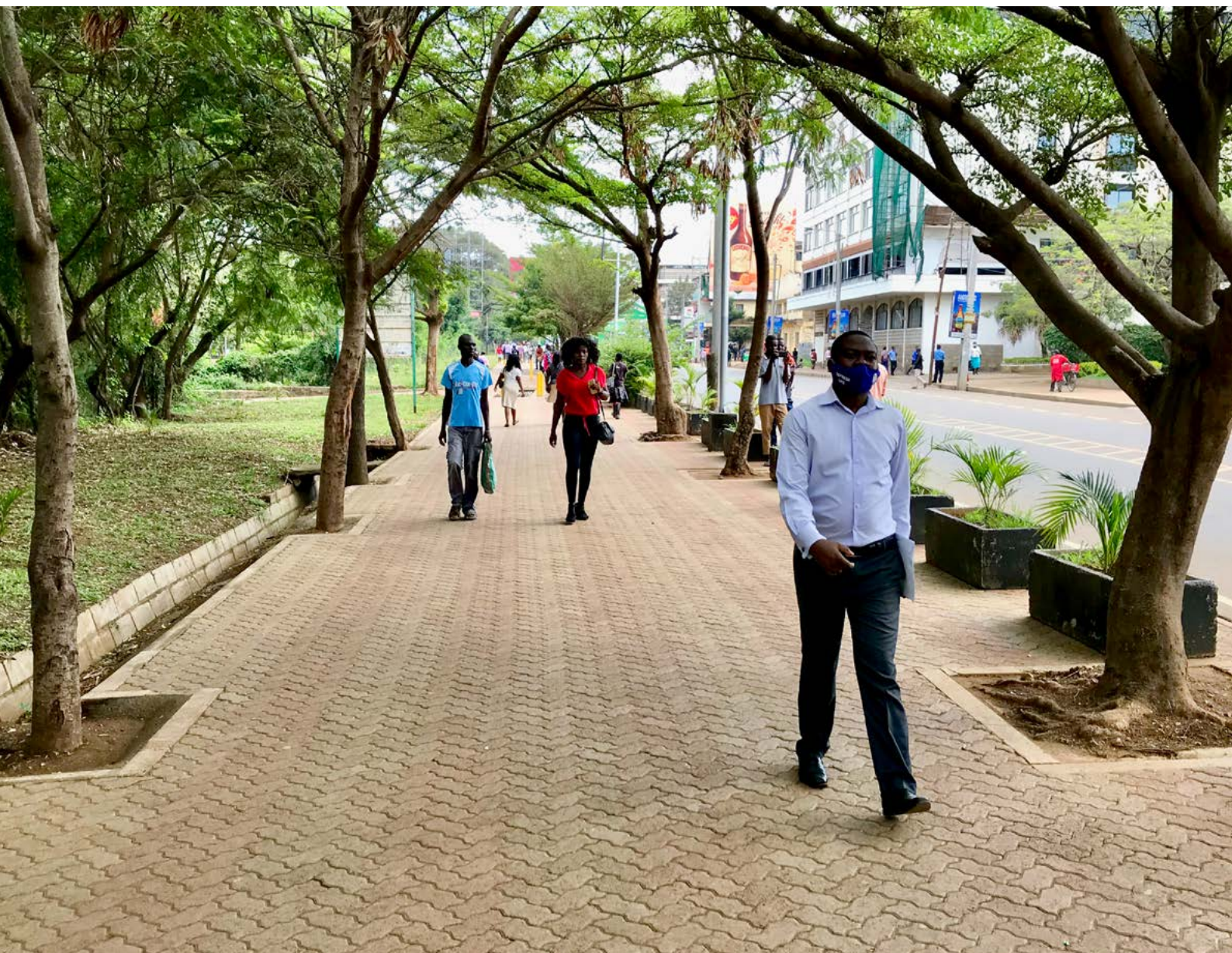

DEC 2022



Version 2.1

This work is licensed under a Creative Commons Attribution 4.0 License. Feel free to copy, distribute, and transmit, as long as you attribute the work.

Photos and graphics courtesy ITDP unless otherwise noted.

PREPARED BY



SUPPORT FROM



Supported by:



based on a decision of
the German Bundestag

ACKNOWLEDGEMENTS

The Street Design Manual for Urban Areas in Kenya was prepared by the Institute for Transportation and Development Policy (ITDP) and UN-Habitat, with support from the Global Road Safety Fund (GRSF), World Bank, and International Climate Initiative (IKI).

The SDMUAK was developed through a participatory process, incorporating input from the Ministry of Roads and Transport, Kenya National Highways Authority, Kenya Urban Roads Authority, Kenya Rural Roads Authority, National Transport and Safety Authority, Nairobi Metropolitan Area Transport Authority, county governments, and National Council for Persons with Disabilities. The Institution of Engineers of Kenya, Architectural Association of Kenya, Kenya Institute of Planners, Town and County Planners Association of Kenya, Kenya Private Sector Alliance, Association for the Physically Disabled of Kenya, cycling community, and public transport operators offered valuable input.

Contributors from ITDP included Christopher Kost, Gabriel Gitau, Gashaw Aberra, Muguru Wairimu, Eng. Nancy Njeri Mburu, Renata Carvalho, and Stanley Chanzu. Michael King, Rick Chellman, PE, and Pranjali Deshpande guided the development of the manual. Eng. Francis Gitau, Infrastructure Secretary, and Eng. James Kungu, Chief Engineer Roads, provided critical leadership during the preparation process

CONTENTS

1. Introduction	1
1.1. Policies and legislation	1
1.2. Institutional Structure	3
1.3. How to use the manual	4
2. Complete street design principles	7
2.1. Designing for safety	7
2.2. Designing for efficiency.....	8
2.3. Universal access.....	10
2.4. Gender sensitive design.....	11
2.5. Child friendly streets	12
2.6. Environmental sustainability	12
2.7. Modal hierarchy.....	12
3. Network design principles	15
3.1. National road and street classification system	15
3.2. Link & place designation	15
3.3. Multi-modal streets	17
3.4. Street network spacing	18
3.5. Complete network configuration	18
4. Street elements	25
4.1. Footpaths	26
4.2. Crossings.....	31
4.3. Cycle tracks.....	34
4.4. Greenways	38
4.5. Matatu/bus stops.....	40
4.6. Matatu/bus terminals	42
4.7. Bus rapid transit.....	44
4.8. Carriageways.....	48
4.9. Traffic calming	50
4.10. Landscaping	52
4.11. Vending	54
4.12. Street furniture	56
4.13. Service lanes	59
4.14. Street lighting	60
4.15. On-street parking.....	62
4.16. Storm water drainage.....	64
4.17. Utilities.....	66

5. Street templates.....	69
6. Intersections	103
6.1. Intersection typologies.....	103
6.2. Operations.....	103
6.3. Geometric design	104
7. Design process	123
7.1. Project identification and conceptualisation	123
7.2. Data and information collection.....	123
7.3. Concept designs	128
7.4. Stakeholder engagement.....	131
7.5. Preliminary designs, cost estimate, and economic evaluation.....	131
7.6. Design review.....	131
7.7. Detailed designs & final cost estimate.....	132
7.8. Tender documentation	132
8. Design checklist	133
9. Definitions.....	134





1. INTRODUCTION

In any urban setting, streets play a critical role in enabling residents to move from one part of the city to the next, meet, conduct business, socialise, and relax. Most African cities have experienced a surge in motor vehicle ownership over recent years. This has resulted in traffic congestion, air pollution, and a deteriorating urban environment. As many cities attempt to accommodate the increasing motorised traffic, more and more of the public realm is taken up by vehicles, leaving little or no space for the social and economic activities that enable cities to thrive. Kenya is currently experiencing unacceptable numbers of road crash fatalities and injuries, resulting in untold misery and loss of economic livelihoods for many families. From 2015 to 2020, road crash related fatalities increased by 26 percent while injuries increased by 47 percent.¹ Pedestrians represent the largest share of road crash victims.

With Kenya's urban population projected to exceed 22 million by 2030, connectivity to education, employment, and social opportunities is fundamental to the development of the country.² Kenya must start providing the required urban transport facilities and services to enable the citizens to access opportunities safely and efficiently.

To address these issues, the Ministry Roads and Transport in partnership with the Global Road Safety Fund (GRSF), Institute for Transportation and Development Policy (ITDP), and United Nations Human Settlements Programme (UN-Habitat) has prepared this Street Design Manual for Urban Areas in Kenya (SDMUAK). The manual seeks to mainstream best practice street designs that prioritise sustainable modes of transport and improve safety for vulnerable street users—particularly pedestrians and cyclists. Besides reducing the risk of death and serious injury, more inclusive urban street designs will enhance access to jobs and opportunities, lower demand for travel by motorised vehicles, and reduce air pollution.

1.1. POLICIES AND LEGISLATION

The desire for safe, attractive, and vibrant streets is reflected in a range of existing transport, planning, and environmental policies and acts. These policies advocate for the creation of streets that persons for all ages and abilities can enjoy together.

- **Constitution of Kenya (CoK) of 2010:** Establishes the devolved system of governance and the formation of county governments, which are tasked with the responsibility for county roads, street lighting, traffic, and parking. The Constitution mandates the national government with construction and operation of national trunk roads and formulating standards for construction and maintenance of county roads. The Constitution guarantees all citizens the right to freedom of movement under article 39(1) and the right to a clean and healthy environment under article 42. All public offices are mandated to respond to the needs of vulnerable members of the society, including women, aged, children, persons with disabilities, and minority/marginalised communities.
- **Integrated National Transport Policy of 2009:** Notes that urban areas, especially Nairobi, Mombasa, Nakuru, Kisumu, and Eldoret, are characterised by an inadequate supply of public transport and competition for limited road space among motorists, pedestrians and cyclists. The policy proposes strict parking policies, access restrictions for private cars, and road pricing in order to manage motor vehicle use. The policy notes the inadequacy of NMT infrastructure and emphasises the need to provide appropriate basic road infrastructure, including walkways, pedestrian crossings, and cycle lanes.
- **Nairobi City County NMT Policy of 2015:** Calls for street designs that adhere to complete street principles incorporating “dignified space” for NMT users, including continuous footpaths and dedicated cycle tracks. Street designs should be based on a user hierarchy that prioritises NMT first and cars second.

¹ Maguro et al. (2020). Trend analysis and fatality causes in Kenyan roads: A review of road traffic accident data between 2015 and 2020. *Cogent Engineering*. Retrieved from: <https://www.tandfonline.com/doi/full/10.1080/23311916.2020.1797981>

² World Bank. (2016). Kenya Urbanization Review. Retrieved from <https://openknowledge.worldbank.org/handle/10986/23753>

- **National Urban Development Policy (Draft of 2013):** Recognises that walking and cycling receive inadequate attention despite being key modes of urban transport. The policy calls for strategies and standards that place emphasis on safe, quality mass transport; pedestrian and cycling facilities; and well-designed public spaces in urban areas.
- **Physical Planning Handbook:** Provides guidelines for physical planning, including planning for transport infrastructure. The handbook calls for dedicated pedestrian and bicycle facilities and adequate landscaping.
- **Kenya Roads Board Act of 1999 (Revised Edition 2012):** Provides for the establishment of the Kenya Roads Board, an agency tasked with distributing revenues from fuel levies for use in road maintenance.
- **Kenya Roads Act of 2007:** Provides for classification, management, construction, and maintenance of public roads in Kenya. The Act establishes the national road authorities and stipulates their functions.
- **Physical Planning Act of 2019:** Provides for the preparation and implementation of physical and land use development plans, including provisions for street networks, footpaths, and cycle tracks.
- **Environmental Management and Coordination Act (EMCA) of 1999:** Establishes the National Environment Management Authority (NEMA) and legal framework for the management of the environment and lists major roads among projects to undergo environmental impact assessment before construction.
- **Urban Areas and Cities Act of 2011 (Revised 2012):** Provides for the classification, governance, and management of urban areas and cities. Parking, traffic control, public transport, and street lighting are listed as requirements for classification of an area as a city or a municipality.



Figure 1. Walking and public transport are dominant forms of mobility in Kenyan cities.



Figure 2. Multi-modal streets support equitable economic growth in urban areas.

- **Traffic Act of 1953 (Revised 2015 [2013]):** Defines the speed limit in urban areas as 50 km/h. This Act also prohibits driving on pedestrian walkways.
- **Street Adoption Act of 1963 (Revised 2012 [1984]):** Regulates the construction, improvement, and adoption of streets by certain local authorities.
- **Highway Code:** Offers guidelines on the use of roads by pedestrians, cyclists, and motorists.
- **Sustainable Development Goals (SDGs):** Kenya is a signatory to the SDGs. SDG 11.2 emphasises the need to provide safe, accessible, affordable, and sustainable transport systems for all irrespective of age, gender or physical ability, by 2030. SDG 3.6 calls for halving the number of deaths from traffic crashes.

1.2. INSTITUTIONAL STRUCTURE

In Kenya, responsibility for the planning, design, management, and maintenance of streets is shared among multiple agencies and levels of government. Effective institutional collaboration is critical to achieve high-quality street environments.

The Ministry of Roads and Transport is responsible for overall transport policy. The three road authorities, namely the Kenya National Highways Authority (KeNHA), Kenya Urban Roads Authority (KURA), and Kenya Rural Roads Authority (KeRRA), are responsible for the management, development, rehabilitation, and maintenance of national roads. The Kenya Roads Board (KRB) oversees the road network and coordinates its development, rehabilitation, and maintenance by administering the Fuel Levy. The National Construction Authority (NCA) regulates the construction industry, including the registration and classification of road

contractors. The Fourth Schedule of the Constitution of Kenya assigns fourteen functions to the county governments in Kenya, one of them being county transport, including construction and maintenance of county roads (classes D, E, and unclassified roads), street lighting, traffic management, parking, and public road transport.

The National Transport and Safety Authority (NTSA) is tasked with minimising the loss of lives through road crashes. The authority is mandated to formulate and implement a National Road Safety Action Plan. The Kenya Police Traffic Department is charged with managing traffic; preventing and investigating crashes; and enforcing laws, rules, and regulations.

1.3. HOW TO USE THE MANUAL

This manual offers guidance on the geometric design of urban streets. For material specifications, drainage design, and construction techniques, users are advised to refer to the accompanying manuals. For the design of roads outside urban areas, readers can refer to Part I: Geometric Design of Rural Roads. Following is a list of the available guidance documents:

- Road Design Manual Part I: Geometric Design of Rural Roads, 1979
- Road Design Manual Part II: Street Design Manual for Urban Areas in Kenya, 2022 (this manual)
- Road Design Manual Part III: Materials and Pavement Design for new Roads, 1987
- Road Design Manual Part V: Pavement Rehabilitation and Overlay Design, 1988
- Road Design Manual Part IV: Bridge Design, 1993
- BRT Design Framework (Nairobi Metropolitan Area Transport Authority)
- Manual on Traffic Control Devices: Part I: Road Marking, 1972; Part II: Traffic signs in Kenya, 1975; and Part III: Traffic signals



Figure 3. This manual covers the unique design requirements of urban streets.

- Standard Drainage Structures Manual: Part 1: Standard small span concrete bridges, 1987 and Part 2: Standard concrete box culverts, 1987
- Standard specifications for Road and Bridge Construction, 1986
- Road Maintenance Manual, 2004
- R2000 operations manuals
- Practice Manual for Water Supply Services in Kenya (Ministry of Water and Irrigation, 2005)
- Draft Practice Manual for Sewage and Sanitation Services in Kenya (Ministry of Water and Irrigation)
- Distribution Standard Guidelines (Kenya Power and Lighting Company)



HUAWEI



HUAWEI

itel

Infinix
NYALI INVESTMENT

TECNO

oppo

Tellom

10 mobile
HUAWEI

TECNO



NEW ARRIVAL
CAMC

KCB
564D

KCB
039

NYALI INVESTMENT

2. COMPLETE STREET DESIGN PRINCIPLES

Streets rank among the most valuable assets in any city. Streets not only ensure residents' mobility, but also are a place for people to meet, interact, do business, and have fun. Streets make a city liveable. They foster social and economic bonds, bringing people together. Decisions about how to allocate and design street space have a tremendous impact on quality of life.

Urban streets have multiple users, including pedestrians, cyclists, public transport passengers, motorists, and freight transport. The design of urban streets must therefore balance the needs of a diverse set of users—a very different exercise from the design of intercity roads, which are primarily geared toward facilitating fast vehicle movement. Effective urban street design ensures safety for all, particularly pedestrians and cyclists, and facilitates efficient use of road space by prioritising public transport.

2.1. DESIGNING FOR SAFETY

Safe urban street design encourages moderate vehicle speeds. Street designs that reduce motor vehicle speeds can significantly improve pedestrian safety since the likelihood of pedestrian death in a traffic collision increases dramatically when motor vehicle speeds rise above 30 km/h. A pedestrian has a 90 percent chance of surviving being hit by a car travelling less than 30 km/h, but only a 50 percent chance of surviving an impact at 45 km/h.

In addition to the risks associated with collisions, high speed also reduces the driver's field of view, thus affecting the driver's ability to respond to changing conditions in the roadway. At speeds below 30 km/h, it is much easier for drivers to see their surroundings and detect potential conflicts with pedestrians, cyclists, or other motor vehicles. Slower vehicles also create a feeling of safety for pedestrians.

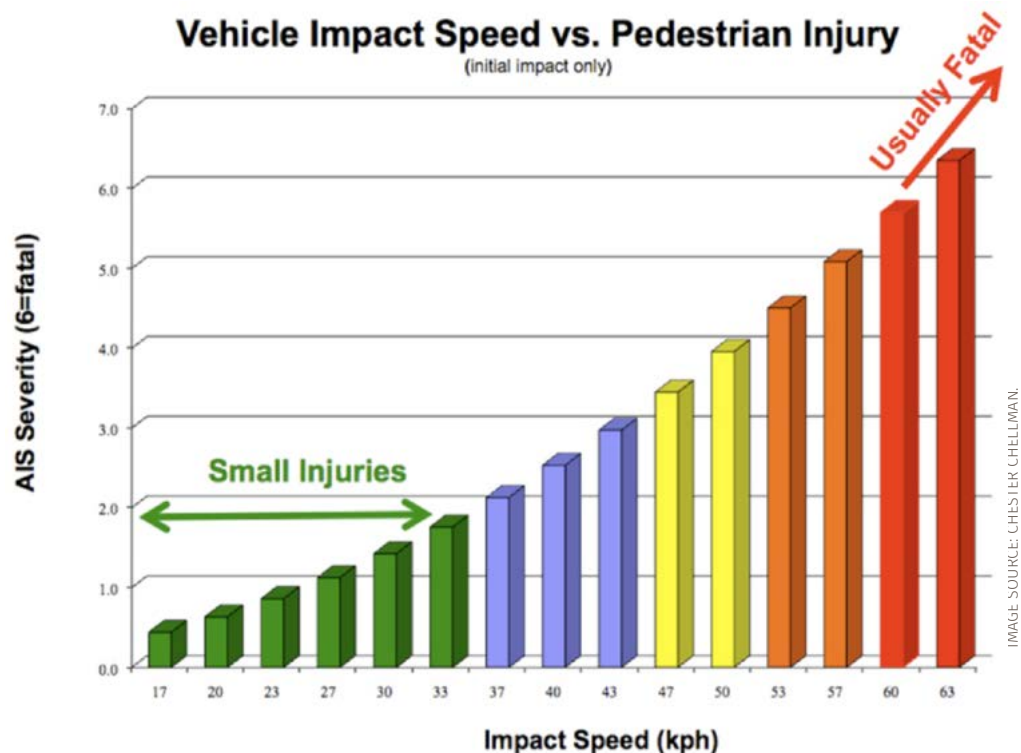

Figure 4. Speed reduction is critical for safe pedestrian environments because the chance of pedestrian death in a collision increases dramatically when vehicle speeds exceed 30 km/h.

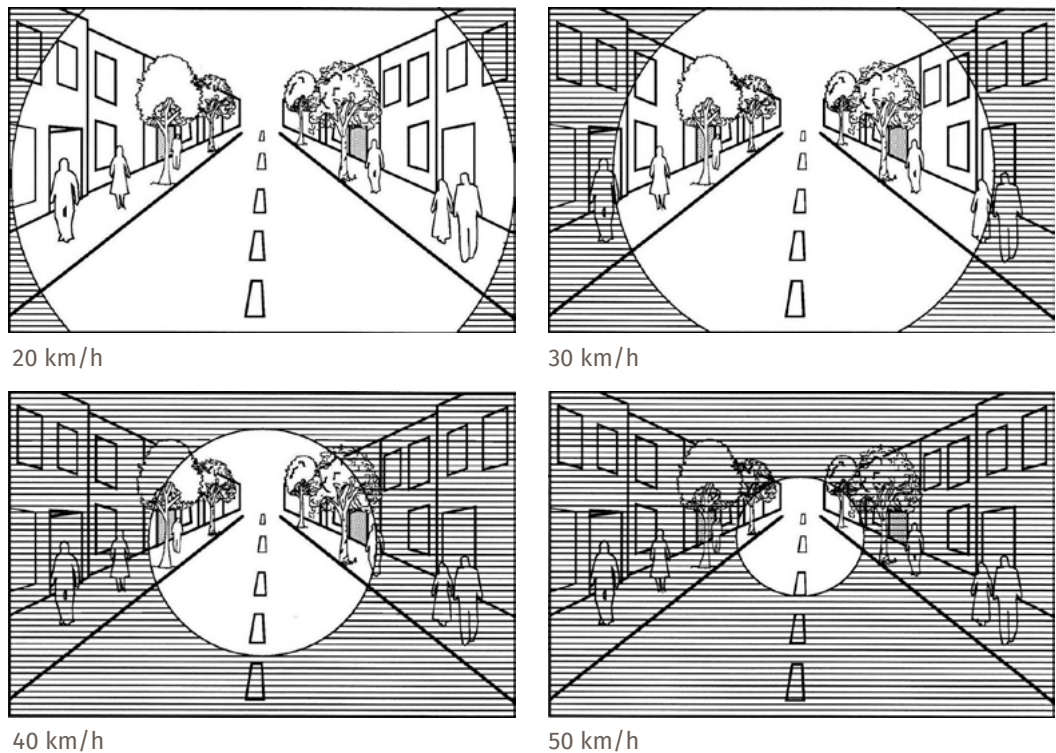

Figure 5. As the speed of a motor vehicle increases, the field of vision narrows, making it harder for the driver to respond to sudden incidents—such as a child running into the street.

The physical design of streets and the provision of footpaths, crossings, and other infrastructure is crucial to managing motor vehicle speeds and creating a safe walking and cycling environment. Accommodating non-motorised modes safely involves the following basic techniques:

- **Systematic traffic calming on smaller streets** to reduce motor vehicle speeds and provide safe places for the mixing of pedestrians and other modes. Shared lanes are safe for pedestrians, cyclists, and motor vehicles to travel together if speeds are restricted to 15 km/h. For speeds up to 30 km/h, separate footpaths are needed but cyclists can travel in the carriageway.
- **Pedestrian and cycle infrastructure that is physically separated from motor vehicle traffic on larger streets**, paired with traffic calming or traffic control to facilitate safe crossing. Pedestrian footpaths should provide clear space for walking, with other elements positioned in a strategic manner. Similarly, larger streets need dedicated cycle tracks with physical separation from mixed traffic. Speeds of up to 50 km/h are appropriate for urban streets.
- **Appropriately designed motor vehicle lanes.** The design of the carriageway should reflect the speed limit. On a multi-lane carriageway, lanes should be restricted to a width of 3.0-3.25 m within urban areas.

2.2. DESIGNING FOR EFFICIENCY

Streets are often designed to maximise the amount of space for motor vehicle movement. Yet vehicle movement and mobility are not one and the same. Mobility is about getting people to where they want to go, efficiently, conveniently, and safely. Mobility can be provided through high-quality, high-capacity public transport, which does not necessarily mean moving large numbers of vehicles. Furthermore, increasing vehicle speeds on urban streets does not necessarily increase capacity. At higher speeds, capacity drops as drivers need more room to operate. In fact, an urban street's capacity is determined largely by traffic signals and intersections.

Street typology

Speed limit for motor vehicles

Sample cross section

Local streets with shared space. At speeds of up to 15 km/h, motor vehicles, pedestrians, and cyclists can safely mix. Traffic calming is needed to minimise vehicle speeds

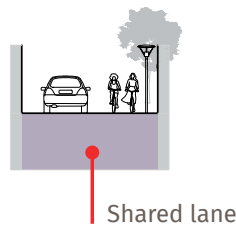

Local and collector streets. Streets with speeds of 30 km/h require separate footpaths. With traffic calming, cyclists can share the carriageway with mixed traffic.

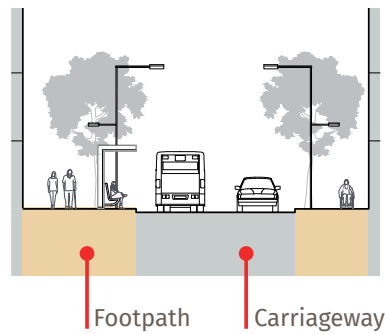

Arterial streets. Streets with speed limits of 40-50 km/h require physically separated cycle tracks and footpaths. Traffic calming or signalisation is required at pedestrian crossings.

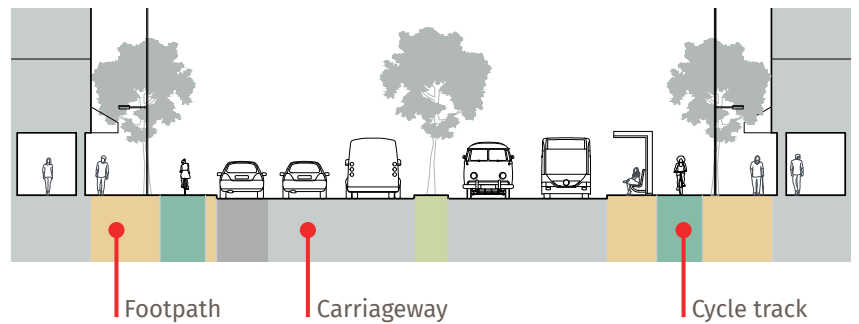

Figure 6. Smaller streets can function as shared spaces where pedestrians walk together with slow-moving vehicles. On larger streets with heavy vehicles and faster speeds, separate space for pedestrians and cycles is needed.

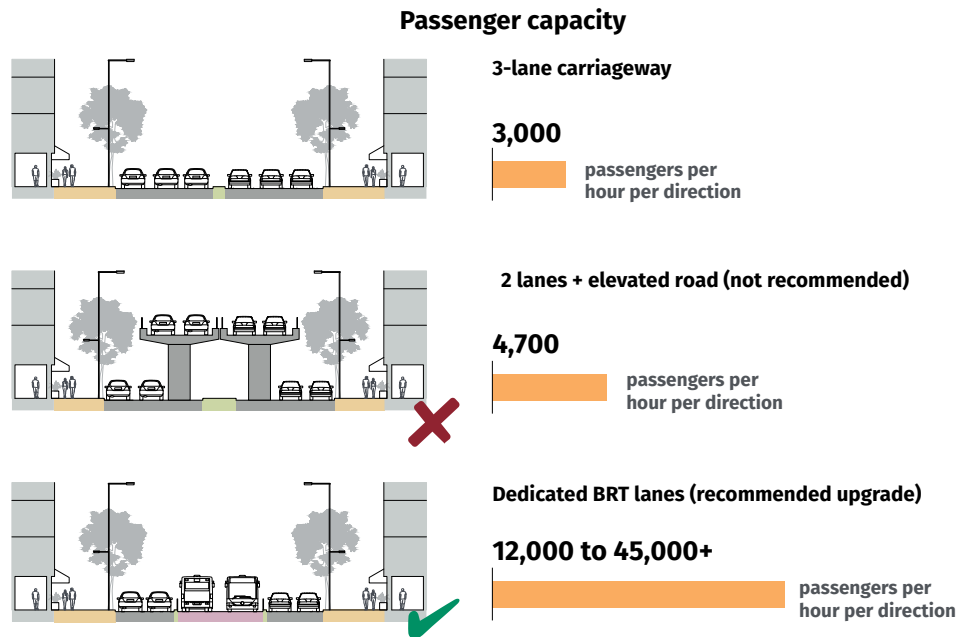

Figure 7. To maximise person-carrying capacity, streets should incorporate dedicated space for public transport and NMT.

While a road widening, flyover, or elevated highway may reduce congestion temporarily, the improvement is usually short-lived. The reason is simple: expanding the available road space initially increases speed and comfort and thereby encourages people to travel more often and take longer trips in private motor vehicles. More and more users take to the route until the wider road returns to its original level of congestion—but with significantly more vehicles stuck in traffic.

The government in turn may feel pressure to widen the road once again, but it is not possible to solve traffic jams by building larger and larger roads indefinitely. In fact, no city in the world has solved its mobility crisis by simply building more roads. On the contrary, some of the cities with the most elaborate road networks also have the worst congestion.

The only viable long-term solution for ensuring mobility is to build high quality facilities for public transport and non-motorised transport. These modes can carry large numbers of passengers without an exponential increase in road space requirements. In most cases, an appropriate solution is bus rapid transit (BRT). A single BRT lane can carry 13,000 passengers per hour per direction (pphd), and if passing lanes are added at stations, the proven capacity increases to 38,000 pphpd. The same lane can carry 800 cars per hour—only 1,000 to 1,600 persons at typical occupancy rates—assuming that the lane receives one half of the signal time at intersections.

There are solutions to traffic congestion too. The key to reducing congestion is lowering the number of vehicles on streets rather than increasing street widths to accommodate an ever-growing number of vehicles. This can be done through various means, including parking fees, congestion pricing, and other travel demand management tools. At a larger scale, compact, walkable transit-oriented development is the key to reducing congestion by keeping trip lengths short.

2.3. UNIVERSAL ACCESS

Universal access is the concept of designing transport services and environments that as many people as possible can use, regardless of age or ability. Per Article 54 of the Constitution of Kenya, persons with disabilities are entitled to reasonable access to places and transport

services. The Persons with Disabilities Act of 2003 further entitles persons with disabilities to a barrier-free and disability-friendly environment, including accessible streets. People with small children, people carrying heavy shopping or luggage, people with temporary accident injuries, and elders can all benefit from an inclusive transport environment.

In order to ensure that persons with disabilities can make complete journeys, needs should be accommodated in each step of the transport chain, from origin to destination. Access to transport is only as strong as the weakest link, so inclusive design must cover public passage, public transport stop and boarding, vehicle interiors, alighting, and passage to the final destination. Streets designed according to universal access principles accommodate assistive devices for particular groups of persons with disabilities. An accessible environment has ample, well connected pedestrian facilities with unobstructed space for movement, consistent pavement surfaces, appropriately sloped ramps, and safe pedestrian crossings. Multiple elements of the streetscape must be designed in an integrated manner.

2.4. GENDER SENSITIVE DESIGN

Until recently, transport planning has tended to take a “one-size-fits-all” approach, assuming that men and women will benefit equally from improvements in transport services. In reality, women and men have different expectations from the transport system and different perceptions of security. Thus, transport policies and plans need to respond to these differences. An integrated and safe transport system provides access to education, work, health care, cultural, and other important activities that are crucial to women’s participation in the society. Of particular concern in the context of street design is the level of safety and security that female users experience. Inclusive designs help to improve the experiences of women and girls, making it easy to walk, cycle, and use public transport.



Figure 8. Well-designed urban streets consider the needs of all users, including women, children, and persons with disabilities.



Figure 9. A safe shared street.

2.5. CHILD FRIENDLY STREETS

Streets should be safe and inviting for children and caregivers. Children have low perception of risks, and drivers cannot easily see children, making them some of the most vulnerable street users. It is therefore crucial that streets be designed with emphasis on children's safety. This can be achieved by providing ample footpaths, safe crossings, physically protected cycle tracks, and speed control features. Street designs can create a playful, inspiring, and educational environment through features such as wide walkways, landscaping, shade, artwork, seating, and play elements.

2.6. ENVIRONMENTAL SUSTAINABILITY

Kenyan cities experience high levels of particulate matter, nitrous oxides, and other dangerous pollutants that contribute to respiratory ailments, heart disease, and lung cancer. Greenhouse gas emissions from vehicles contribute to the global climate crisis, which is already affecting Kenya in the form of increased incidence of droughts and flooding. Street design that encourages use of public transport and active modes can enable a shift away from the use of polluting cars. Street design features such as tree cover and permeable surfacing also contribute to urban resilience, helping to mitigate the urban heat island effect and absorb water runoff.

2.7. MODAL HIERARCHY

To promote safe, efficient designs, this manual uses modal hierarchies to inform design and operation decisions. The main modes include pedestrians, bicycles, public transport, personal vehicles, and freight. The default hierarchy for this manual is pedestrian > bicycle > public transport > freight > personal vehicles > personal vehicle parking.

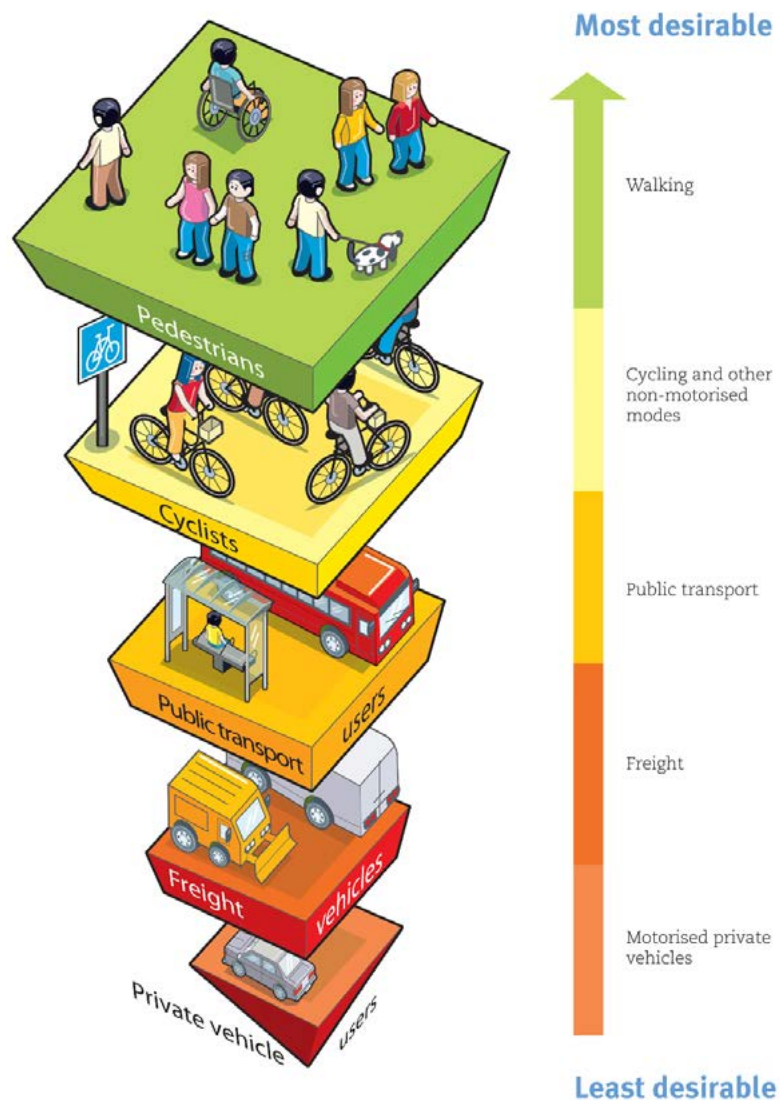

Figure 10. To encourage the design of safe and efficient streets, this manual prioritises pedestrians, cyclists, and public transport in the user hierarchy.



PLATINUM
DIAL *619#
TO APPLY FOR
LOANS
0709 900 000

DIAL *400#



3. NETWORK DESIGN PRINCIPLES

City streets do not exist in a vacuum—they are part of street networks. Networks are typically grid-like, or variations thereof. For the past 70 years, street networks have largely been seen as mono-modal: designed to facilitate driving. Other considerations, from other modes to other uses of the street, are often ignored. This section discusses how a street network can be planned and designed to be more “complete.”

3.1. NATIONAL ROAD AND STREET CLASSIFICATION SYSTEM

Rural roads and urban streets in Kenya were classified through the Kenya Gazette Supplement No. 4 of 2016 (22 Jan), Fourth Schedule. The Gazette notice defines two classes of roads: National Trunk Roads, comprised of classes A, B, and C; and County Roads, comprised of classes D, E, F, G, and others.

The classification recognises the differences between rural roads and urban streets, offering a parallel coding system for urban streets. When roads traverse cities or rural centres, their designs need to reflect the local context. Designs should be modified to signal to drivers that they have entered an urban area. Once the corridor passes out of the urban area, the rural cross section can resume.

The national street classification system is important for funding, reporting, and bureaucratic requirements. While it focuses on the vehicle throughput function of a street, it is silent on the many other aspects of complete streets and networks, which are discussed in this section.

Table 1. Road classification per Gazette Supplement No. 4 of 2016.

Functional category	Rural road class	Urban road class
Arterial	S	-
	A	Au / H
	B	Bu / J
Collector	C	Cu / K
	D	Du / L
	E	Eu / M
Local	F	Fu / N
	G	Gu / P

3.2. LINK & PLACE DESIGNATION

Every urban street has a “link” and “place” designation. Link describes the vehicle circulation, access, and throughput function of a street. Arterial, collector, and local are link designations. Conversely, place describes the context, neighbourhood, land use, transect, and built form of a street. Central business district, commercial centre, suburban, residential, informal settlement, and industrial are all place designations. Street designs need to respond to the character of the place, regardless of the link designation of the corridor.

The link designations are taken from the Kenyan street classification system. The place designations have been created. **Central business districts (CBDs)**, or downtown areas, are the commercial and business centres of Kenyan cities and towns. CBDs have commercial activities



Central business district



Commercial centre



Suburban



Residential



Informal settlement



Industrial

Figure 11. Place designations.

as their primary land use and play a central role in the city's economic activities. The streets in CBDs see heavy foot traffic and should incorporate generous footpaths, wide crossings, cycle tracks, seating, and landscaping, to cater to all users. Streets in downtown areas also require defined vending zones and frontage areas to serve local commerce.

Commercial centres are secondary mixed use hubs. These areas may contain retail, office, and residential activities. The streets in commercial centres need to incorporate adequate footpaths to serve the pedestrians accessing commercial uses in the area as well as those who reside there. Streets in such areas also need to be integrated with playgrounds and parks to cater for local residents, especially children. Traffic calming is critical, especially where malls, office complexes, and other uses attract high volumes of motor vehicles. Examples of commercial centres include Kondele in Kisumu, central Kilimani in Nairobi, and Links Road in Mombasa.

Suburban areas combine medium density residential uses and some commercial activities, especially offices. Streets in these areas need adequate footpaths and cycle tracks to cater to commuters accessing local employment as well as residents. Traffic calming is needed to manage the speed of through traffic. Many streets in Nairobi's Westlands and Parklands areas and Mombasa's Nyali neighbourhood fall in this category.

In **residential** areas, the primary use is housing. Some retail activities may exist, but they primarily cater for the local population. Motorised and non-motorised traffic are separated on major streets, but most local streets can have shared space, with traffic calming to maintain vehicle speeds at 15 km/h or below. Many estate areas fall into this category.

Streets in **informal settlements** are unique because they have limited right-of-way and are often the sole public spaces available to local residents. In many cases, it is not feasible to separate motorised and non-motorised traffic, so streets need to manage high volumes of pedestrians and cyclists along with the occasional vehicle moving at moderate speeds. Adequate street

lighting is critical for residents' security. Street upgrades in informal settlements should be aligned with efforts to improve water and sewage infrastructure.

Industrial zones may contain large- and small-scale manufacturing, warehouse, transport, and related activities. Industrial zones serve as employment centres for a broad spectrum of workers and thus need footpaths, cycle tracks, and adequate tree cover for non-motorised movement. Industrial zones need pavements that can handle the axle loads of recurring goods movement, and they are the only zones in urban areas that require 3.5 m carriageway lanes. Traffic calming, especially at pedestrian crossing locations, can ensure that movement of heavy vehicles does not endanger pedestrians and cyclists.

3.3. MULTI-MODAL STREETS

Urban streets are inherently multi-modal; however, the functions for specific modes may not mirror the legal classification of the street. For example, a BRT system could ply on a collector, thereby making it an "arterial" for public transport. Similarly, if an arterial has cycle tracks, then it would be an "arterial" for cyclists; otherwise not.

Table 2 describes recommended multi-modal configurations by street class to be used as part of this guide. Urban arterials (i.e., classes Au and Bu) can incorporate footpaths, cycle tracks, at-grade crossings, and public transport facilities, with design speeds of 50 km/h or below. Traffic calming measures should be provided to keep vehicle speeds moderate and enhance pedestrian safety. Collector streets in urban areas (classes Cu and Du) typically have footpaths, cycle tracks, and, in some cases, public transport services. Local streets in urban areas (classes Eu, Fu, and Gu) can have separate footpaths and carriageways, with cycles operating in the carriageway. Alternatively, a local street can be designed as a shared space, with all vehicles sharing the same space at low speeds (i.e., 15 km/h or below). See Section 5 for typical street configurations.

Table 2. Recommended multi-modal configurations by street class.

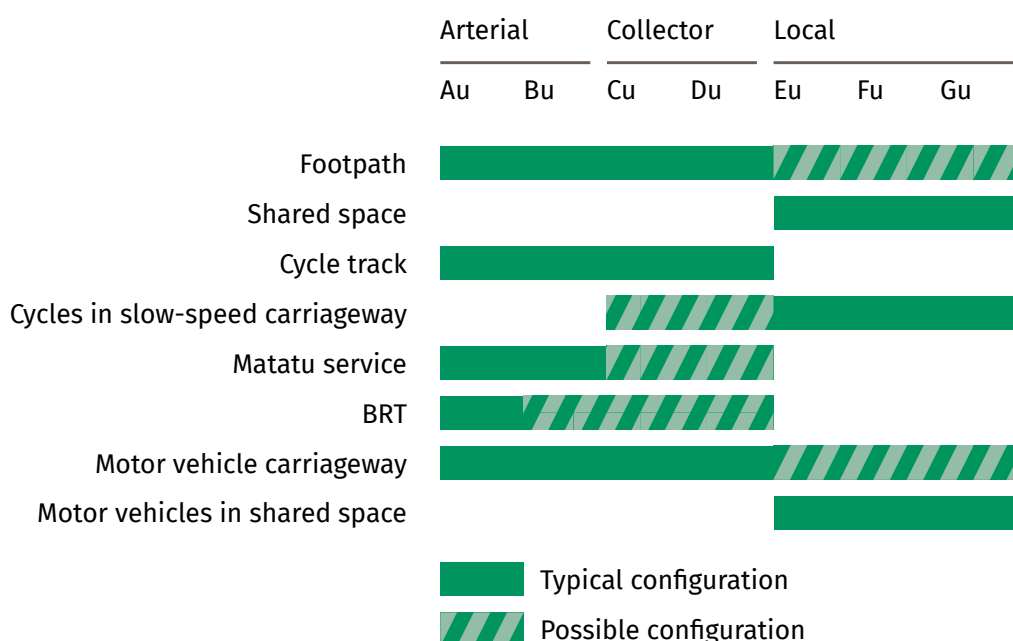

3.4. STREET NETWORK SPACING

Street networks have spacing requirements. Blocks should be of a particular dimension to facilitate walking. Main driving roads (e.g., arterials) should only occur ever so often lest the system overload. Public transport lines and stops are spaced to balance speed (e.g., of BRT buses) and access (to the stop or station). Table 3 lists the network spacing to be used as part of this guide. This guidance is intended to address:

- **Operational efficiency and safety:** Higher category streets have a limited number of motor vehicle crossings to facilitate operations of public transport. Lower category streets are spaced closely to provide access to each parcel.
- **Connectivity for all road users:** Smaller blocks facilitate walking and cycling.
- **Distribution of resources:** Rather than simply upgrading one main corridor through a community, mobility planning should emphasise the need for a complete street network.
- **Adequate amount of land in the public realm:** County spatial plans and local physical and land use development plans should aim to allocate at least 20 percent of urban land to streets and pedestrian access routes.

To support the permeability of the pedestrian network, streets should incorporate pedestrian crossings at existing or expected desire lines, such as at bus stops, schools, or cross streets. If crossing behaviour is not considered, road corridors themselves can become barriers to pedestrian connectivity, dividing one part of a community from another. It is important to maintain neighbourhood access even as a street is being upgraded.

Table 3. Spacing of streets and facilities.

Type of street or facility	Classification	Spacing (m)
Public transport	Express stop/station	600-800
	Local stop/station	300-500
NMT	Cycleway	150-200
	Walking path	20-40
	Street crossing	60-120
Street (vehicle)	Arterial (Au, Bu)	1,000-1,500
	Collector (Cu, Du)	250-500
	Local (Eu, Fu)	60-100
	Local (Gu)	30-50

3.5. COMPLETE NETWORK CONFIGURATION

Complete streets and networks have the power to create walkable communities where people are safe from traffic violence and have a lower greenhouse gas footprint. This section outlines a process to create a complete network that prioritises walking, cycling, and public transport. Motor vehicles are accommodated, but in a supportive role.

The typical street grids traditionally used are shown in Figure 12. Districts are outlined by arterial roads and highways. The district on the left is divided by a series of collectors, which are in turn sub-divided by a series of local streets. There is no hierarchy, even though the street classification suggests one. One can drive on any street in any direction. It is mono-modal

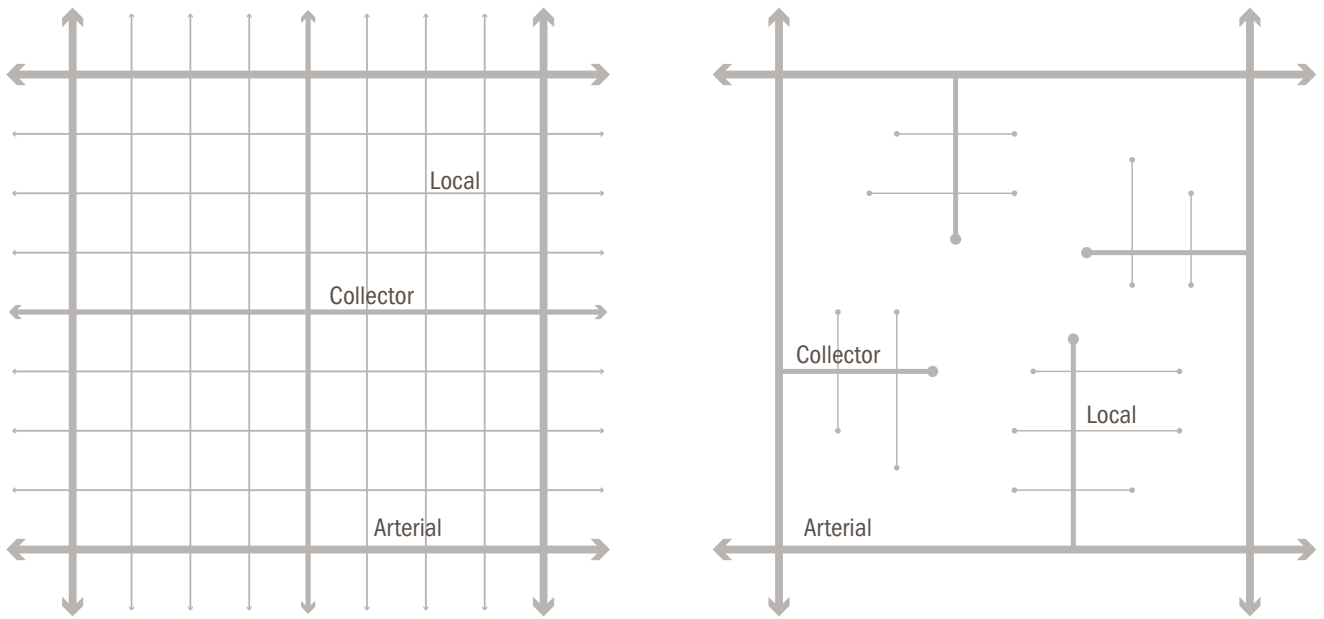

Figure 12. Traditional mono-modal street grids for motor vehicle movement: typical non-hierarchical street grid (left) and typical hierarchical street grid (right).

with no regard for walking, cycling, or public transport. This network is a plumbing diagram for traffic. The district on the right is hierarchical. It funnels drivers from local streets to the arterials via collectors. While it is also mono-modal and auto-centric, there is no through traffic on smaller streets.

By contrast, the starting point of a complete network is public transport and walking. Public transport can move large numbers of people quickly and efficiently in urban areas. A well-connected street network enables public transport to operate within walking distance of all urban residents. Street networks should enable public transport services to operate with direct

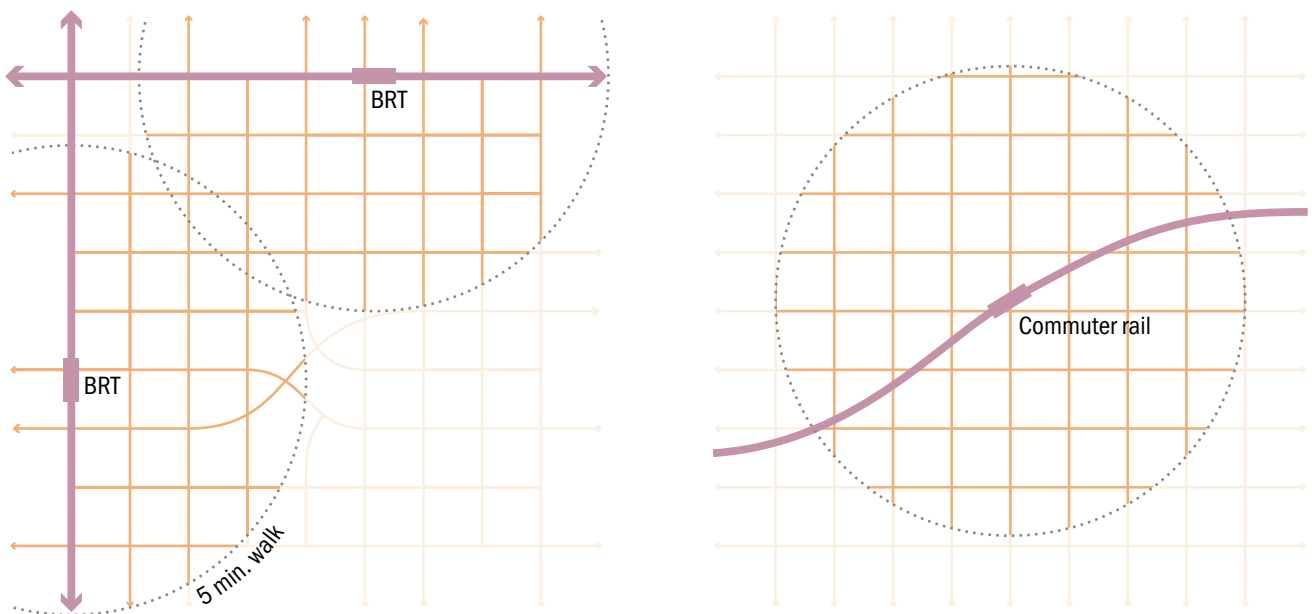

Figure 13. Transit-oriented districts: BRT-based (left) and rail-based (right).

routing and minimal detours. High-demand corridors can incorporate dedicated right-of-way services such as bus rapid transit (BRT) to enable buses to bypass the jam. On corridors with regular matatu services, street designs should provide for convenient public transport access through shelters, signage, and safe pedestrian crossings.

Walking is a dominant mode in Kenyan cities, and public transport trips also start and end on foot. As a healthy and pollution-free form of mobility and recreation, walking is key to urban life. Pedestrian networks must have complete, publicly accessible walkways where all destinations are connected to each other and protected from vehicle traffic.

Figure 13 shows two versions of a representative transit-oriented district. On the left is a BRT system that plies the arterial street network. On the right is a rail-based system that does not follow the street network. Both have a network of streets and paths that lead to the rapid transit stations. Both diagrams use a 5-minute (400 m) walking radius.

Greenways, paths, and other non-motorised transport facilities play a key role in complete networks. Cycling offers low-cost, pollution-free mobility. For cycling to be safe and comfortable for people of all ages, cities should create complete cycle networks serving all city areas and key destinations through the shortest possible routes. The cycle network can include various types of facilities, including slow-speed neighbourhood streets, physically separated cycle tracks on major streets, and cycle paths running through parks and greenways. The cycle network should be integrated with public transport systems and pedestrian priority areas. Secure cycle parking should be available at destinations.

Figure 14 shows the greenway and cycle track components of a complete network. The left image illustrates how cycling facilities may or may not follow the grid. Aside from corridors on streets, the cycle network can follow a river or train tracks. On the right, the greenways are overlaid on the BRT-based transit-oriented grid.

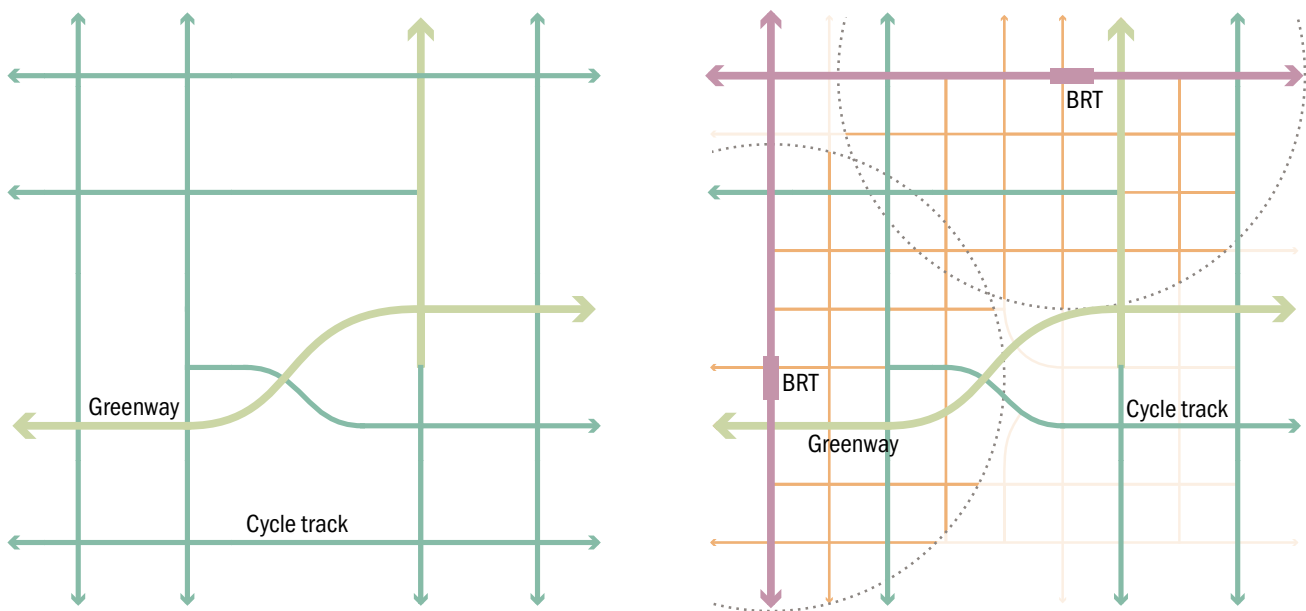

Figure 14. Greenway components (left). Transit-oriented district with greenway (right).

Complete networks accommodate motor vehicles, but in a supportive role. They are primarily for service and deliveries. Specific measures, including on-street parking systems and congestion charging, manage the overall use of personal motor vehicles. These measures should seek to cap the overall vehicle kilometres travelled by personal motor vehicles over time and limit the mode share of personal motor vehicles to 20 percent or less of trips.

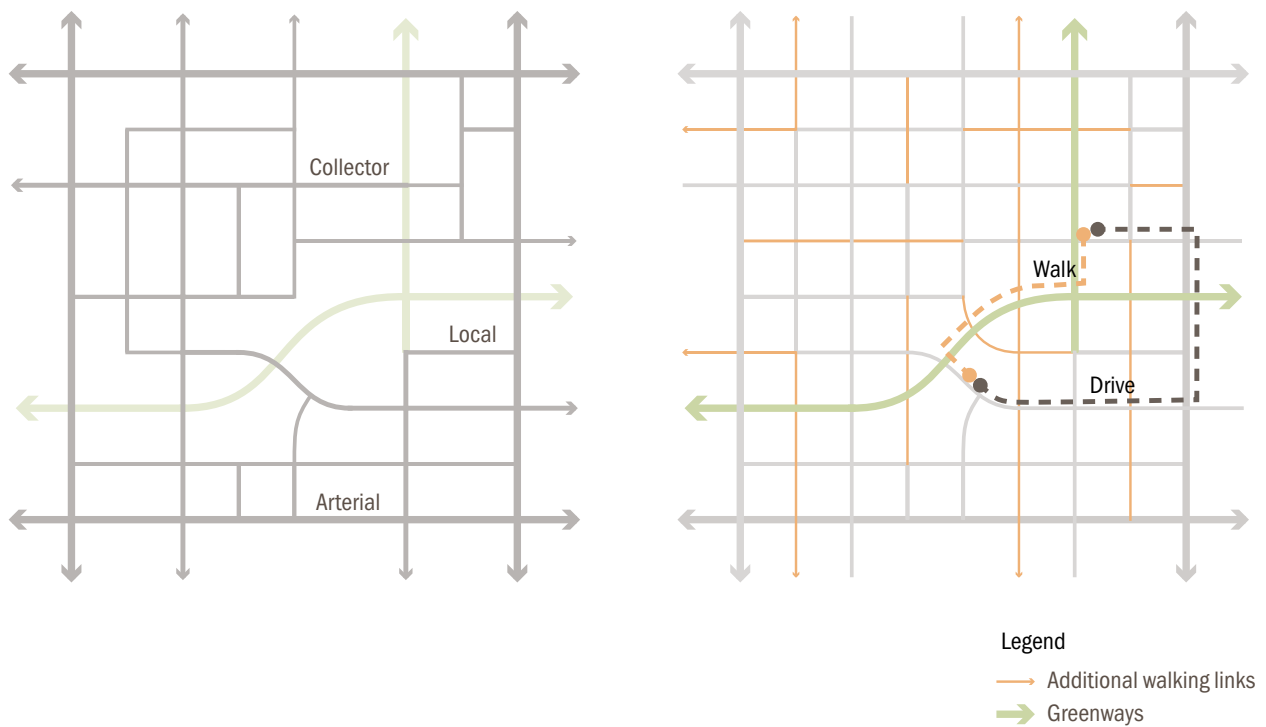

Figure 15. Motor vehicle network (left). It is often faster to walk or cycle within the district (right).

The motorist network (as shown in Figure 15) should provide access to the urban area while ensuring safety and efficient movement for pedestrians, cyclists, and public transport. A well-connected motor vehicle network can reduce bottlenecks and congestion. To ensure safety for all users, motor vehicle speeds must be managed carefully through traffic calming, appropriate street spacing, safe intersection designs, and automatic enforcement. Local and



Figure 16. A complete network may include some links dedicated to pedestrians and cyclists.



Figure 17. Fine-grained street networks offer multiple routes to destinations.

collector streets lead drivers to perimeter arterials. Through traffic is discouraged. By contrast, interconnected walking networks with short block lengths allow for short and direct routes through neighbourhoods for pedestrians and cyclists. As shown in the right image, it will often be faster to walk or cycle within the district.

With the various components in hand, a composite network can be formed, as seen in Figure 18. The starting point is public transport, in this case a surface based BRT system (red) passing through the district, providing access to the majority of residents within a 5-minute walk of the stations. Emanating out from the stations are the principal walkways (yellow)—promenades for people accessing the station, and also probably the signature streets of the district. Walking spurs connect to these walkways and provide access to all blocks and surrounding districts.

Greenways (yellow green) pass through the district, potentially along waterways. Cycleways (green) provide high-speed and comfortable passage for cyclists. Cycling infrastructure also extends the reach of the BRT stations. A network for drivers circumscribes the district, but does not interrupt it. Access is provided to all blocks, but drivers are channelled to the surrounding arterials. Motor vehicles support the neighbourhood, but do not define it.

The centre of the community is highly “green”—oriented towards walking, cycling, and public transport. Fine-grained networks offer multiple routes to various destinations and make it convenient to complete trips by foot or cycle. In areas where large blocks exist, redevelopment provides an opportunity to break up large blocks to improve pedestrian connectivity. The complete, transit-oriented district supports access for residents of all incomes, genders, and abilities.

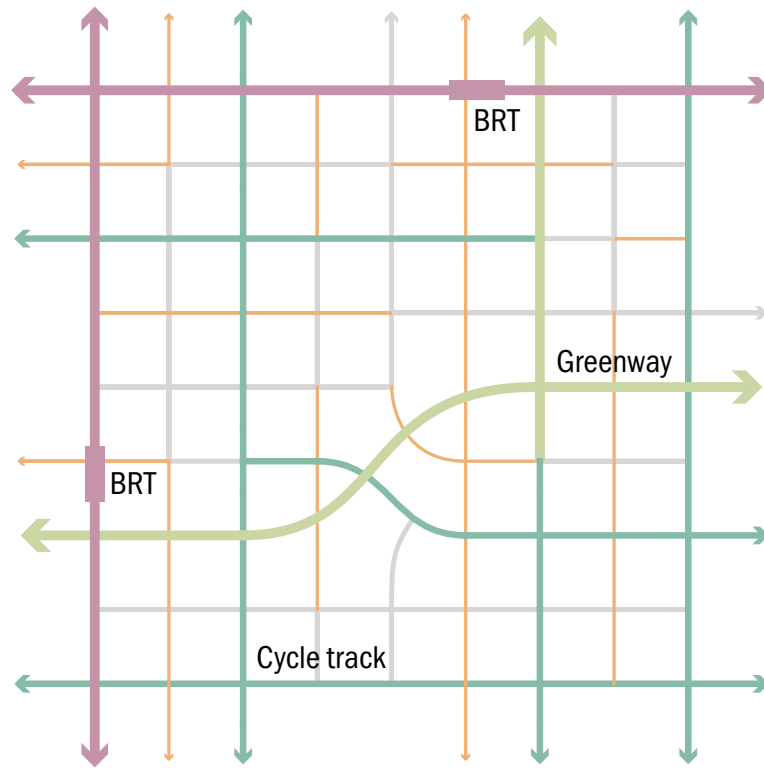

Figure 18. The complete, transit-oriented network.

KABAR
UNIVERSI
(NAIROBI CAMPUS)

The Monarch Insurance
Reception - 4th Floor
Opening Hours
Monday - Friday: 8.30am - 5.00pm
Saturdays: 9.00am - 1.00pm

First Community Bank
BUREAU DE CHANGE
First Floor

CHASE BANK
The Relationship Bank
6th Floor

NC



4. STREET ELEMENTS

Street design elements accommodate or serve specific functions. For example, a footpath supports pedestrian movement, and street lights improve safety. Street design elements demand detailed planning and need to be customised to fit the local context. Getting the elements in the right proportion and location is challenging because all elements interact with one another. For example, utility-oriented elements lie mainly underground, but when they surface in the form of utility boxes and manhole covers, they can impact the usability of elements such as footpaths and cycle tracks.

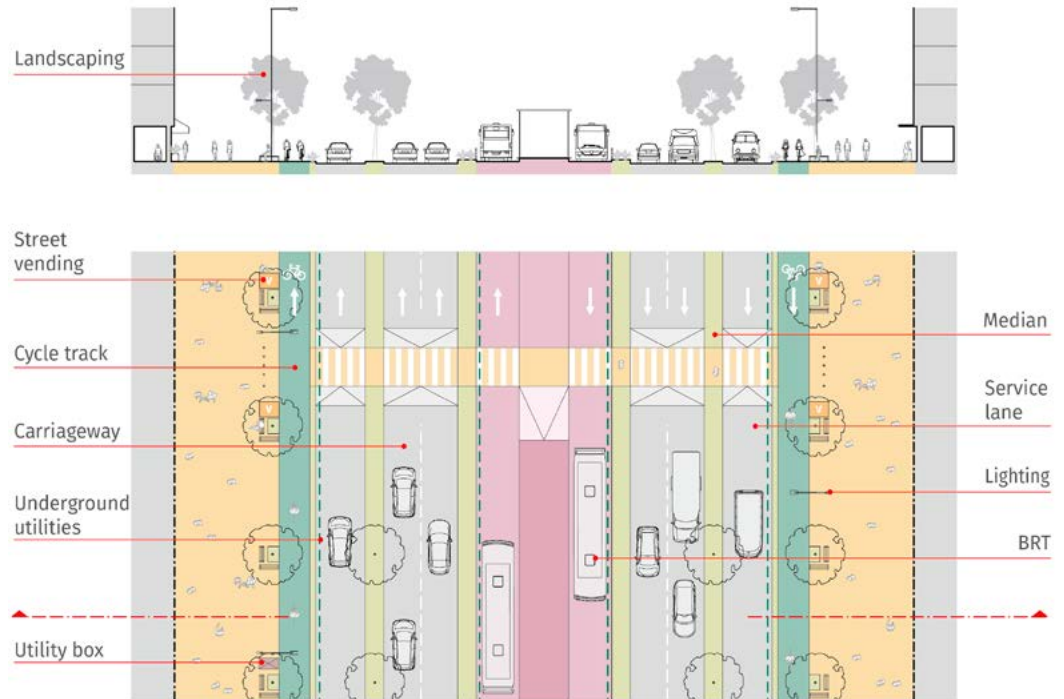

Figure 19. Main street design elements discussed in the manual.

4.1. FOOTPATHS

Good footpaths promote safe and comfortable pedestrian mobility. As the primary public space in a city, they should be accessible to all users, regardless of age, gender, or special needs. Comfort, continuity, and safety are the governing criteria for the design and construction of pedestrian facilities. For this reason, the footpaths are divided into three main zones: the frontage zone, the pedestrian zone, and the furniture zone. The pedestrian zone provides continuous space for walking and should be clear of any obstructions.

DESIGN CRITERIA

- ▶ Minimum clear width of 2 m. For areas with high pedestrian volumes, wider footpaths should be provided (see Figure 23).
- ▶ Elevation over the carriageway of +150 mm.
- ▶ Ramp slopes no steeper than 1:10. Slopes of 1:12 are preferred.
- ▶ Continuous shade through tree cover.
- ▶ No railings or barriers.
- ▶ Bollards to prevent encroachments by cars. Spacing of 900 mm between at least one pair of bollards for universal access.
- ▶ Constant height at property entrances. Ramps can be provided for vehicles, with a slope of 1:6 to 1:12 (maximum 1:4).
- ▶ Cross slope no more than 2%.
- ▶ Tactile pavers for people with visual impairments.



Figure 20. Footpaths designed per the zoning system provide uninterrupted walking space for pedestrians. The pedestrian zone should have at least 2 m of clear space.

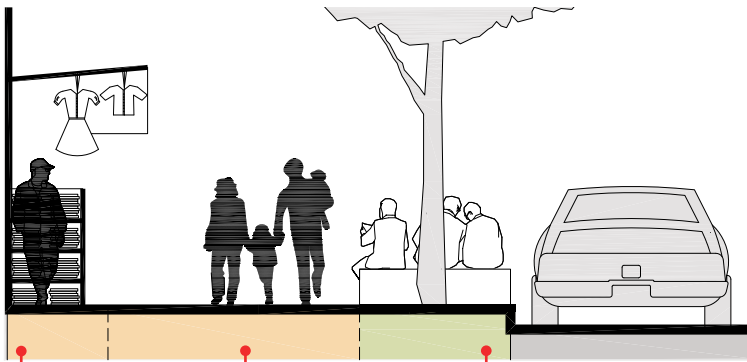

Figure 21. Footpaths have distinct zones that serve separate purposes.

Frontage zone.
Provides a buffer between street-side activities and the pedestrian zone.

Pedestrian zone.
Offers continuous clear space for walking. The clear width must be entirely free of obstructions.

Furniture zone.
Contains trees, street lights, benches, utility boxes, and other potential obstructions.

Smallest footpath/
tree pit package

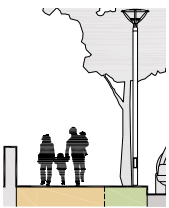

Pedestrian zone	Furniture zone
2 m	1 m

Commercial centre with moderate pedestrian volumes

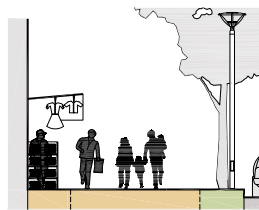

Frontage zone	Pedestrian zone	Furniture zone
1 m	3 m	1 m

Central business district with high pedestrian volumes

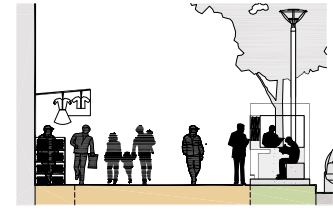

Frontage zone	Pedestrian zone	Furniture zone
1 m	4 m	1.5 m

Figure 22. The smallest well functioning footpath has a width of 3 m, including 2 m of clear space. Wider footpaths are recommended in areas with large pedestrian volumes.

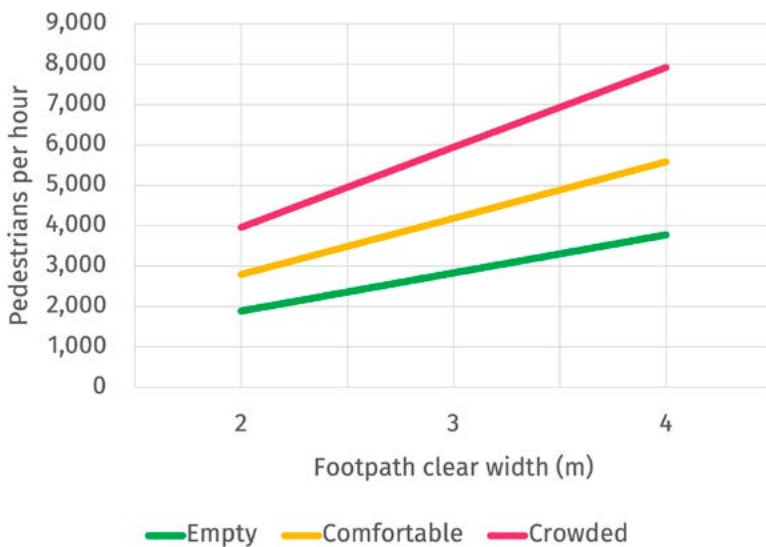

Figure 23. Relationship between footpath width and capacity. The widths represent the unobstructed clear width.

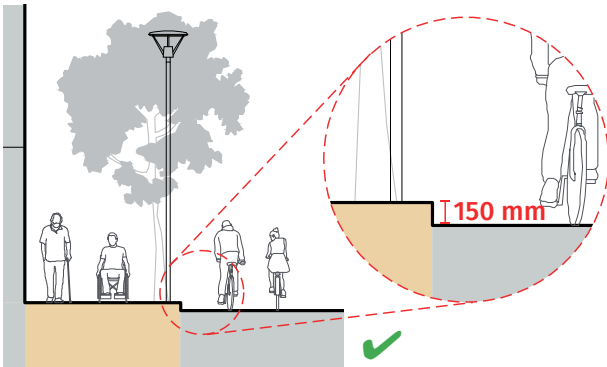
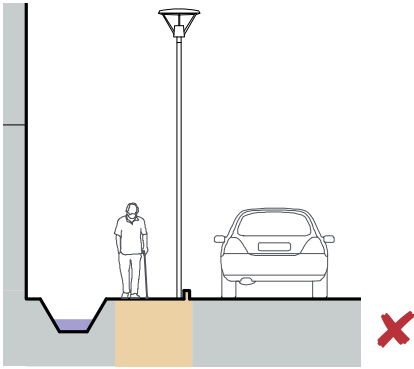

Figure 24. Footpaths placed below the carriageway often experience waterlogging. Footpaths should be raised +150 mm above the carriageway. A cross slope of 2% is required.

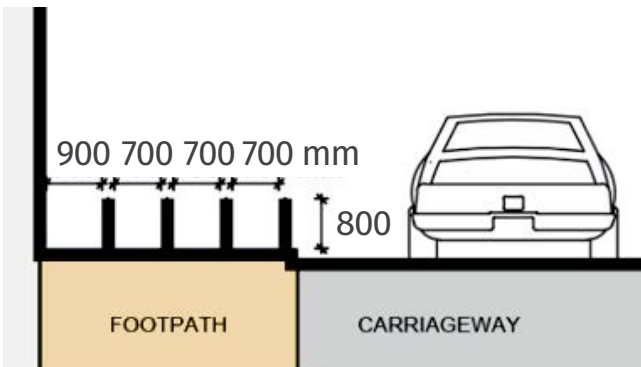

Figure 25. Bollards should be installed to prevent vehicles from parking on footpaths, with spacing of 900 mm between at least one set of bollards to allow wheelchairs to pass.

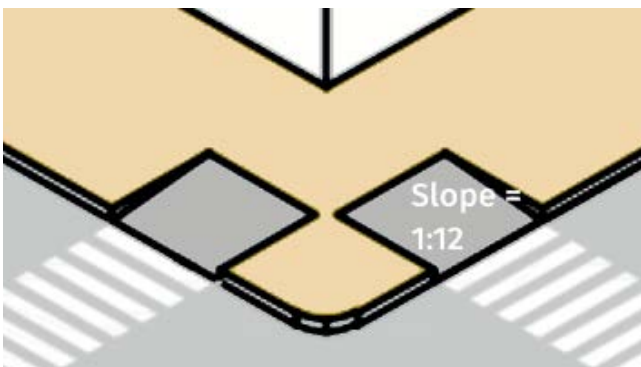
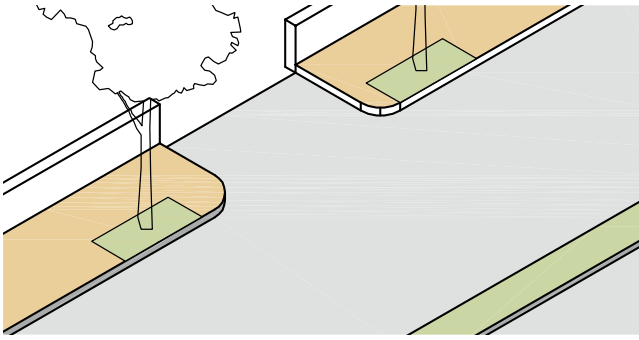
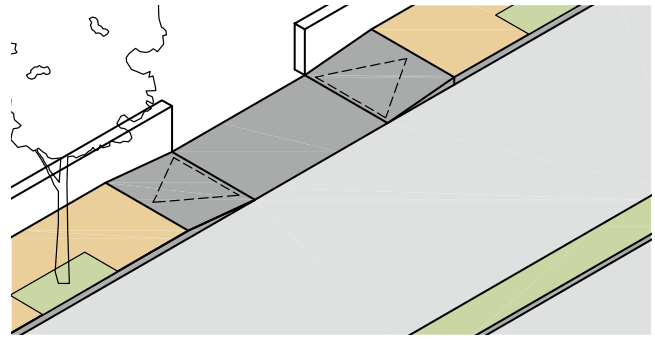

Figure 26. Where footpaths are ramped down to the level of the carriageway, the maximum ramp slope is 1:12.



✗ Ending the footpath with abrupt kerbs renders the footpath inaccessible for many pedestrians.



✗ Lowering the entire footpath to the level of the carriageway is unacceptable as property entrances may become waterlogged.

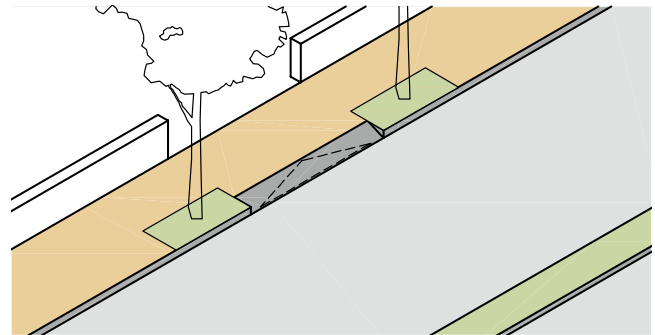

✓ Where required to provide the access to private properties, vehicle ramps should be provided in the furniture zone.

Figure 27. Footpaths should remain at the same level at property entrances and small side streets, with ramps for vehicles, in order to improve convenience for pedestrians and maintain universal access.

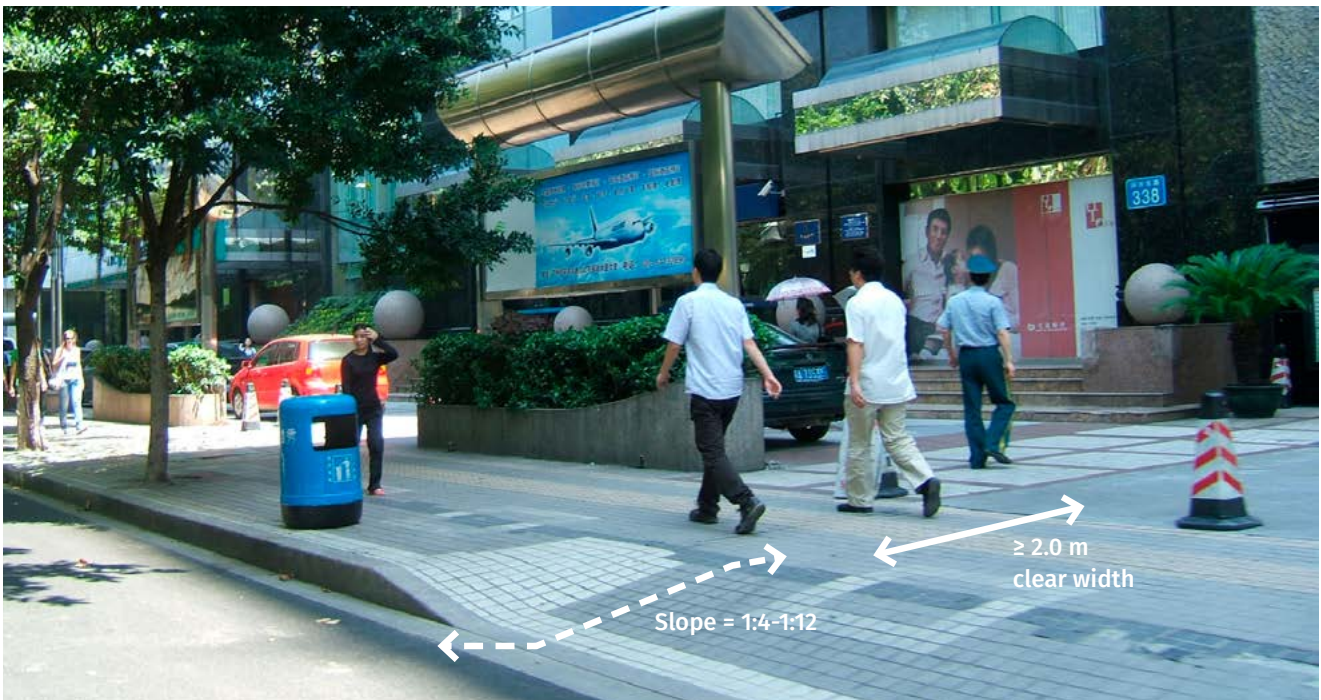

Figure 28. Footpaths that maintain a constant level through property entrances are convenient for pedestrians to use. Vehicles use a ramp, helping to reduce speeds.

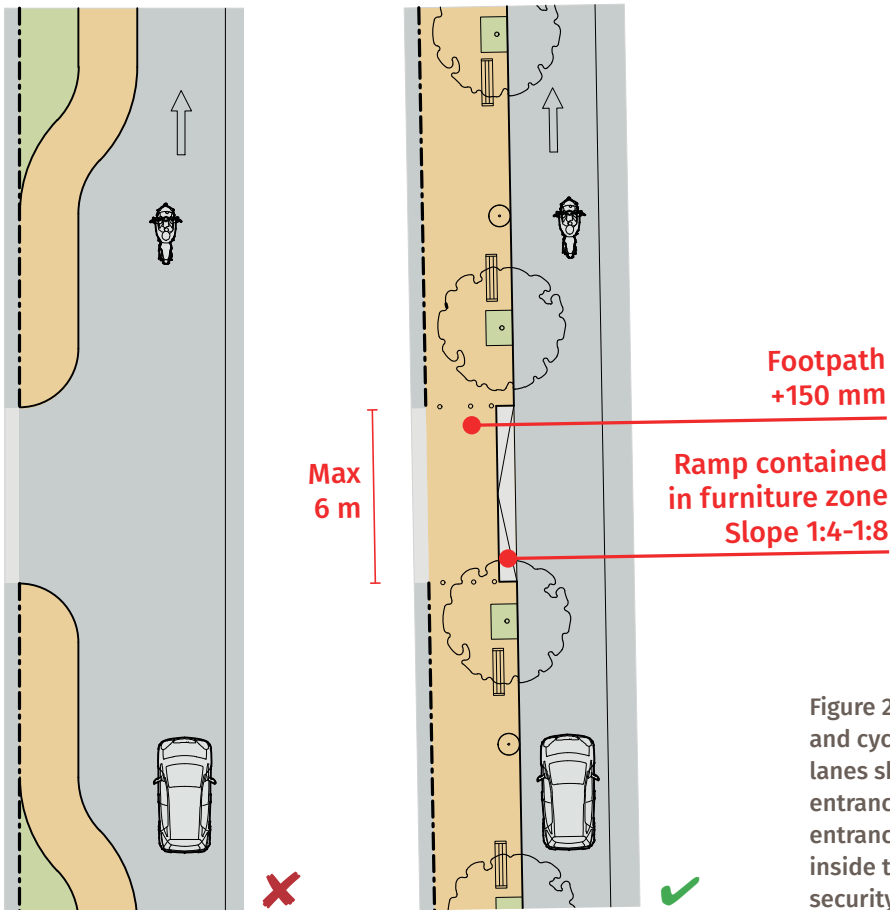
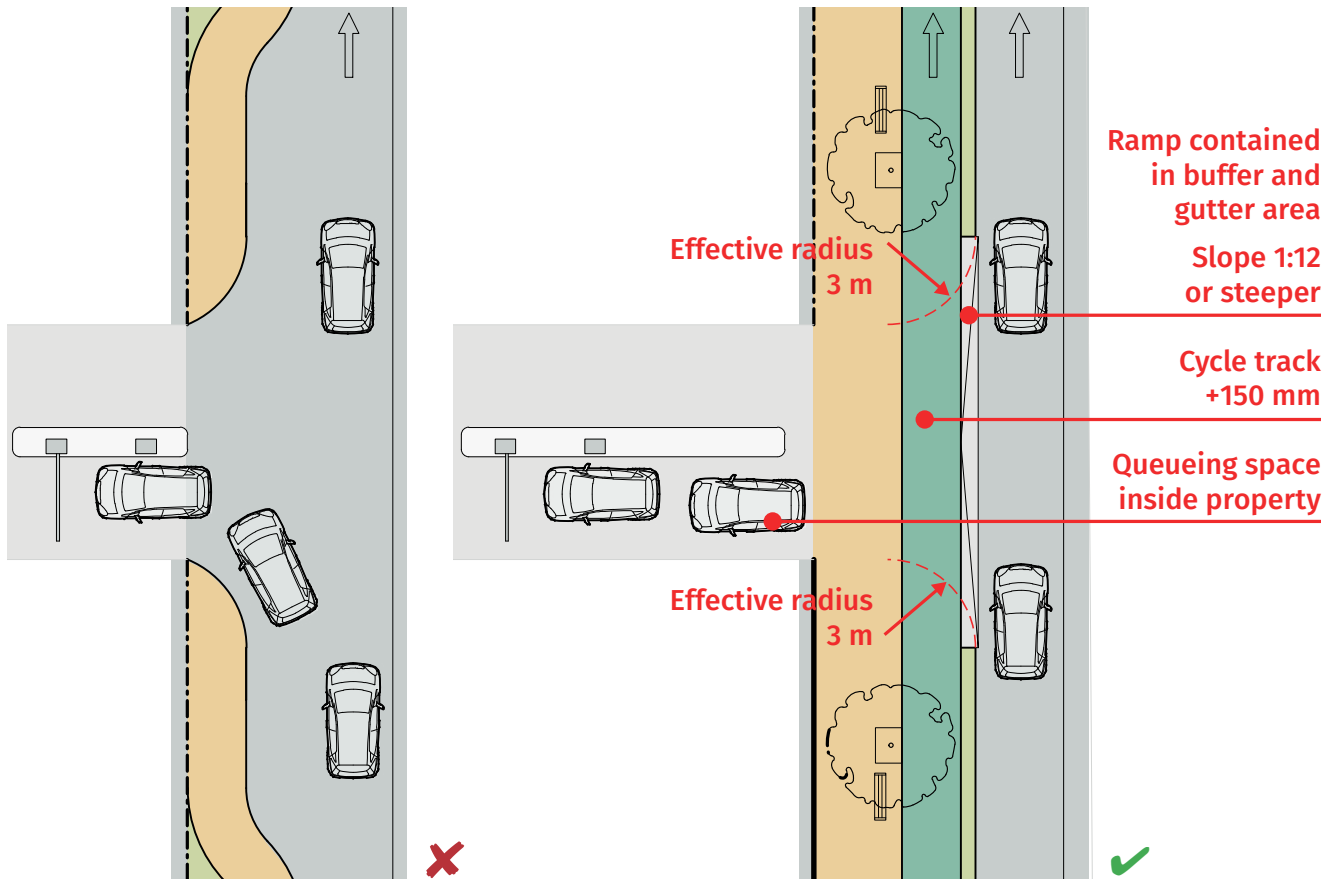

Figure 29. To improve safety for pedestrians and cyclists, acceleration and deceleration lanes should not be used at property entrances on urban streets. Commercial entrances require sufficient queueing space inside the property for vehicles undergoing security checks.

Residential property entrance



Commercial property entrance

4.2. CROSSINGS

Good crossings allow pedestrians and cyclists to cross busy streets safely and conveniently. A pedestrian crossing should be located wherever there is a concentrated need for people to cross the street (e.g., at a matatu stop, entrance to a shopping mall, or where a path intersects the street). In busy commercial areas, crossings should be spaced at more frequent intervals.

At-grade crossings are superior to pedestrian foot overbridges or tunnels. Pedestrians dislike having to climb a stairway in order to cross the street, so they are likely to avoid it and will cross at grade as they please. This preference makes costly overbridges and tunnels an unwise use of limited resources. To ensure safety, at-grade crossings should have traffic calming (e.g., in the form of a tabletop crossing or speed humps) or signal control.

DESIGN CRITERIA

- ▶ Pedestrian crossings should be located at pedestrian desire lines.
- ▶ Signalised or raised to the level of the footpath to provide universal access and traffic calming. People can cross a street with up to two lanes, low vehicle volumes, and slower speeds (i.e., 30 km/h or below). If a street has two or more lanes per direction, higher volumes, or faster speeds, crossings are made safer through median refuge islands combined with traffic calming and/or signal control.
- ▶ For tabletop crossings, the height should match the height of the adjacent footpath. A ramp slope of 1:8 is preferred. For more information on ramp slopes, see Section 4.9.
- ▶ If a speed hump is used, the hump should be placed 5 m before the crossing.
- ▶ Drainage inlets should be provided upstream of the tabletop crossing to prevent waterlogging.
- ▶ The pedestrian crossing should have a width of 5 m or equivalent width to the adjacent footpath, whichever is larger.
- ▶ Bulb-outs should be added in parking lanes to reduce the crossing distance.



Figure 30. Pedestrian crossings should be direct and should offer universal access.

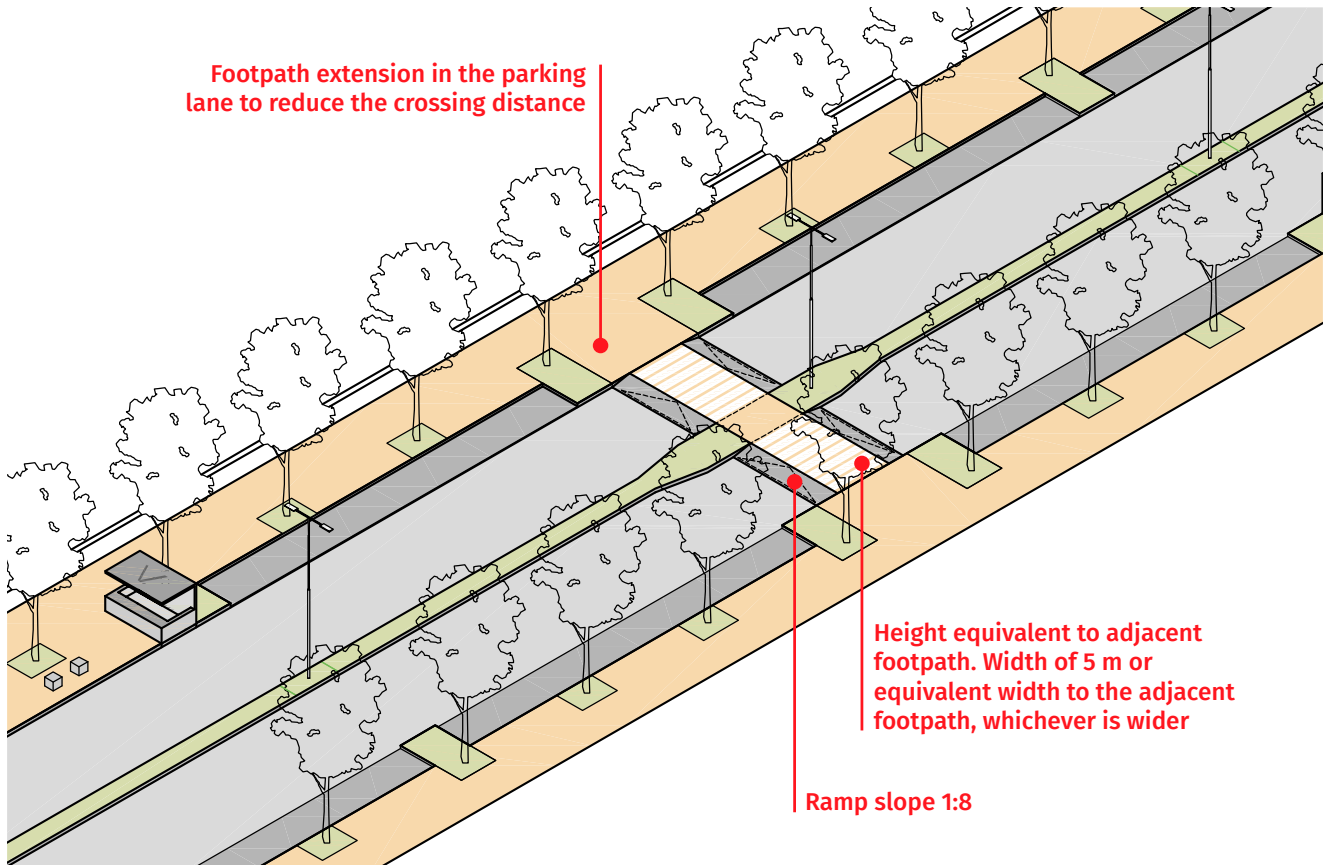

Figure 31. Raised pedestrian crossings offer universal access and reduce vehicle speeds to improve safety.



Figure 32. A tabletop crossing provides safe access to a BRT station.

BEST TO AVOID: FOOTBRIDGES & SUBWAYS

In an attempt to increase motor vehicle speeds, at-grade pedestrian crossings are frequently replaced by footbridges or subways. Since these facilities are inaccessible to many people, they should be avoided on urban streets. Grade-separated pedestrian crossings have numerous drawbacks:

- ▶ **Increase in travel time.** Footbridges lead to circuitous walking routes that typically increase travel distances and times, thereby discouraging walking. Pedestrians typically seek out short, direct routes to their destinations.
- ▶ **Lack of universal access.** Footbridges are often inaccessible and increase barriers to persons with disabilities, people carrying luggage, and parents with strollers. Extensive ramping may be installed to accommodate wheelchairs and bicyclists, but long crossing distances and steep slopes still discourage use.
- ▶ **Obstructions on footpaths.** Due to land constraints, footbridges sometimes block footpaths and cycle tracks. In order to accommodate both footbridges and footpaths, there might be a need to acquire land outside the public right-of-way (ROW), which can be expensive.
- ▶ **Prohibitive cost.** Footbridges cost upwards of twenty times as much as at-grade crossings.
- ▶ **Harassment and other crimes.** Grade-separated crossing facilities are potentially unsafe with regard to sexual assault and other crimes, especially during night-time hours, since the facilities are by definition removed from street-level activity and the security it provides.
- ▶ **Increased vehicle speeds.** Grade separation tends to increase motor vehicle speeds, further degrading the overall walking environment in the vicinity of the footbridge, especially for those who cross at grade.



✘ Figure 33. Footbridges often represent a wasted investment. When presented with a choice, pedestrians prefer to cross at street level.

4.3. CYCLE TRACKS

On streets with faster speeds, cycle tracks can reduce conflicts between cycles and motor vehicles. Cycle tracks make it possible for even novice users of all ages to opt for cycling. Efficient cycle tracks are safe, convenient, continuous, and direct.

DESIGN CRITERIA

- ▶ Physically separated from the carriageway—as distinguished from painted cycle lanes, which offer little protection to cyclists.
- ▶ Clear width of at least 2.0 m for one-way movement. The clear, or “effective” width, is the width clear of obstructions such as utility poles, shrubs, etc. 3.0 m of clear width for two-way movement. For the relationship between cycle volumes and width, see .
- ▶ A smooth surface material—asphalt or concrete. Paver blocks should be avoided.
- ▶ Elevated 150 mm above the carriageway.
- ▶ Positioned between the footpath and carriageway. Provide a buffer of at least 0.5 m between the cycle track and carriageway. The buffer should be paved if it is adjacent to a parking lane. Increase the buffer to 0.75 m next to buildings, walls, etc.
- ▶ Bollards to prevent encroachments by cars. One bollard placed in the middle of the cycle track, to allow for cyclists to pass on either side. Bollard spacing of 1.2 m.
- ▶ See Table 5 for facility selection.

Table 4. Relationship between cycle track width and volume.

One-way volume (bicycles/hr)	Bidirectional volume (bicycles/hr)	Effective width (m)*
< 150	N/A	2.0
150-750	< 100	3.0
> 750	> 100	4.0

* Add 0.5 m where there are 10% or more tricycles or cargo bicycles.

Table 5. Bicycle facility selection.¹

Bicycle facility	Motor vehicle speed, 95th percentile	Motor vehicle volume, daily, both directions
Shared street	≤ 15 km/h	-
Bicycle boulevard (bicycles in moderate-speed carriageway)	≤ 30 km/h	< 2,000 and under 50 motor vehicles per hour, peak hour, peak direction
	≤ 40 km/h	< 1,500 and under 50 motor vehicles per hour, peak hour, peak direction
Cycle track or protected bike lane	≤ 40 km/h	≥ 1,500
	> 40 km/h	≥ 1,500

¹ Adapted from NACTO. (2014). Urban Bikeway Design Guide.



Figure 35. This cycle track is physically separated from the carriageway, has a smooth surface material, and is wide enough for cyclists to overtake one another.

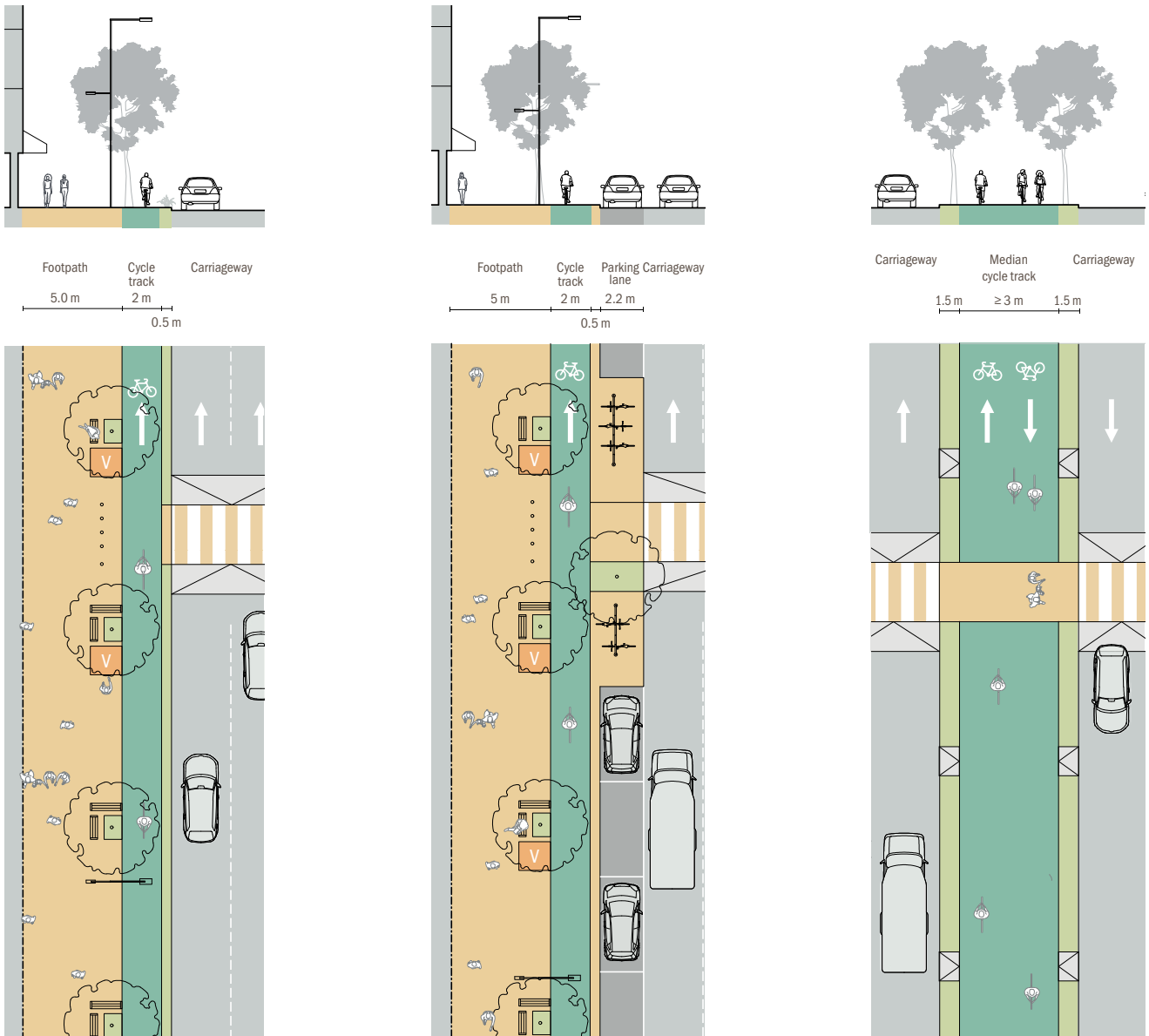
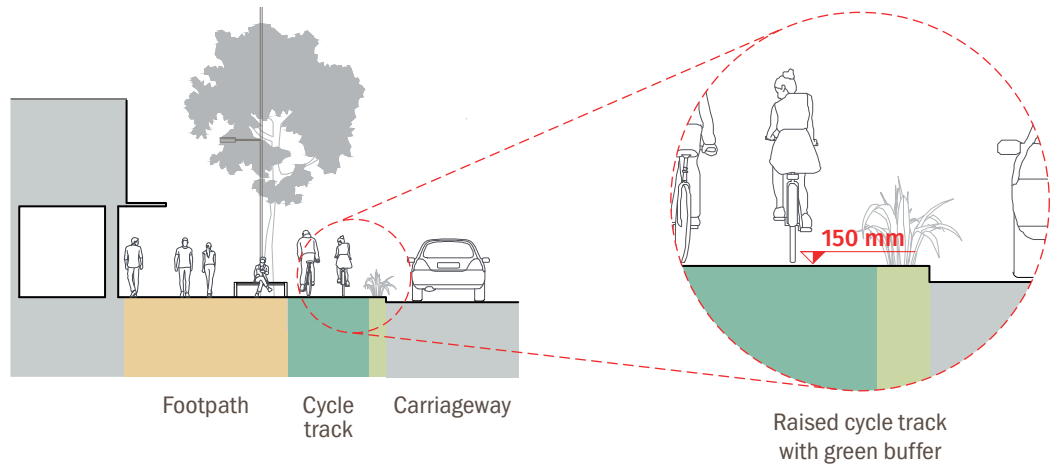
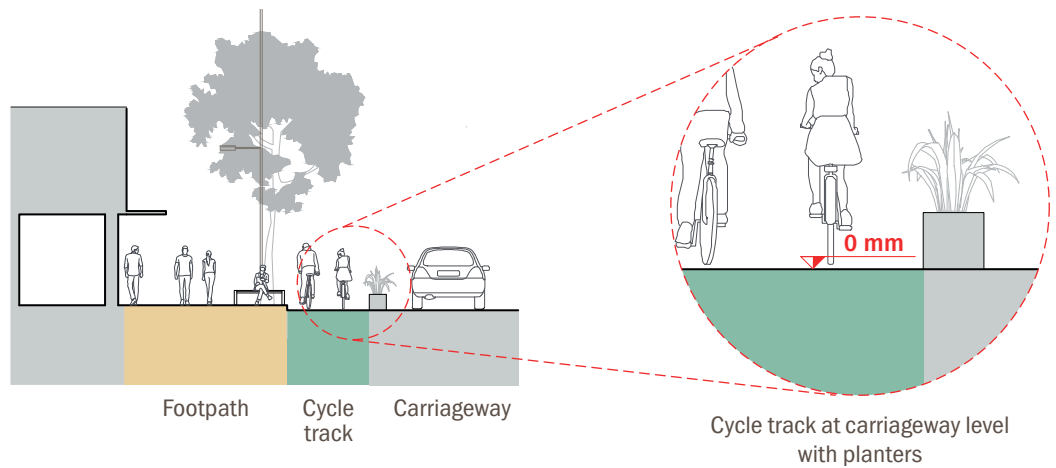

Figure 34. For one-way movement, cycle tracks should have a width of 2 m plus a 0.5 m buffer next to the carriageway. The width should be increased to 3.0 m for two-way movement.



✓ **Figure 36.** Cycle tracks should be elevated +150 mm above the carriageway to allow for storm water runoff and prevent the accumulation of debris.



! **Figure 37.** A cycle track can be developed through the installation of planter boxes or kerbs within the existing carriageway space, provided that there is adequate drainage to prevent waterlogging and accumulation of debris in the cycle track.

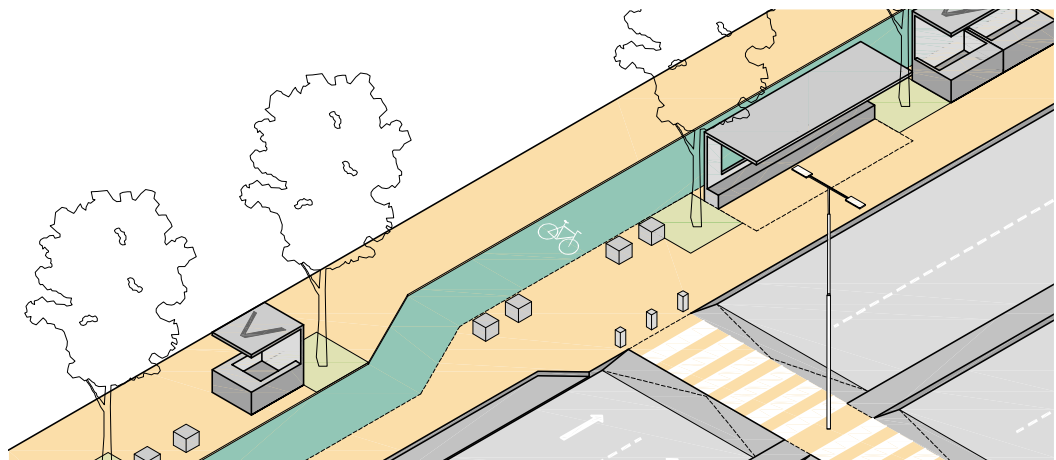

Figure 38. Shift cycle tracks behind bus stops to create sufficient waiting area for passengers.



Figure 39. Newly constructed cycle tracks should be physically separated from motor vehicle traffic and raised +150 mm above the carriageway.



Figure 40. Part of an oversized carriageway can be re-purposed as a cycle track. Physical separators protect cyclists from motor vehicle traffic.

4.4. GREENWAYS

Greenways are multipurpose urban mobility corridors for cyclists and pedestrians with ample tree cover to provide shade. They offer continuous, safe, and unobstructed facilities for non-motorised traffic use, complementing the street network. Greenways can facilitate the reclamation of waterways and can improve access to open space.

DESIGN CRITERIA

- ▶ Connectivity to existing pedestrian networks, cycle networks, and open spaces.
- ▶ Exclusive access for pedestrians and cyclists. Bollards to prevent encroachment by vehicles.
- ▶ Effective width of at least 3.0 m to serve as a shared space for pedestrians and cyclists. Increase effective width to 4.0 m where there are more than 25 people walking or 250 people cycling (both directions, per hour). Provide separate paths for each mode where there are more than 50 people walking or 500 people cycling (both directions, per hour).
- ▶ Tabletop crossings where the greenway crosses the street network.
- ▶ Organised spaces for street vending.

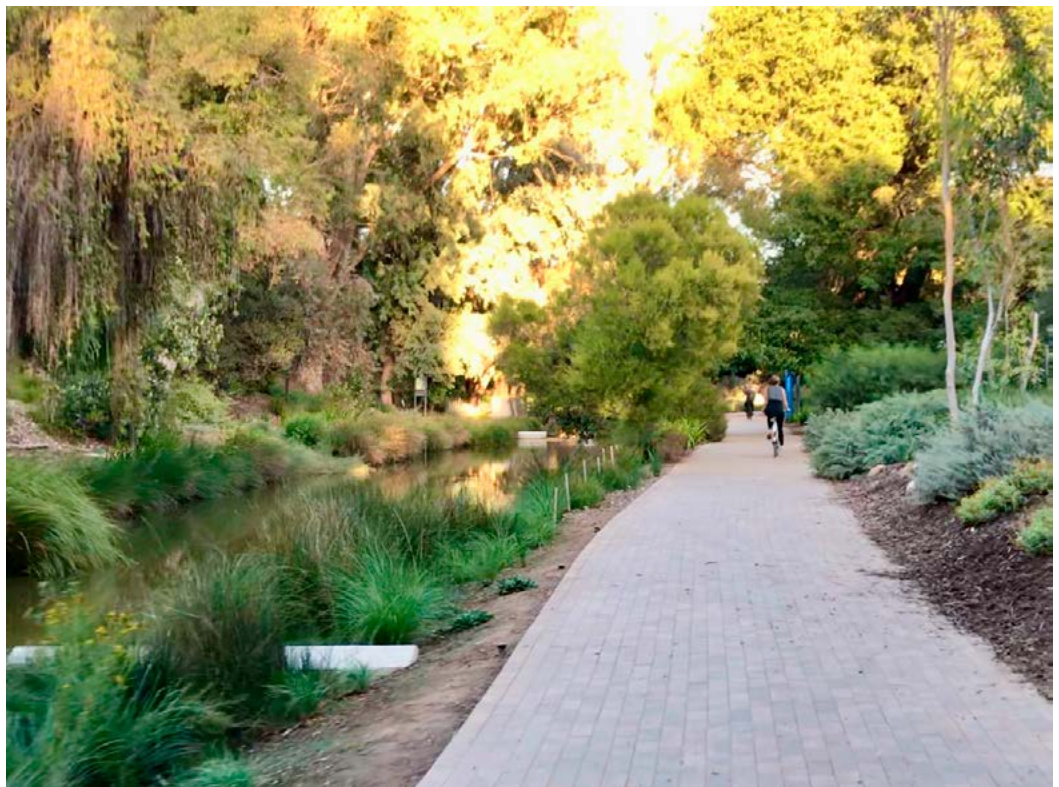
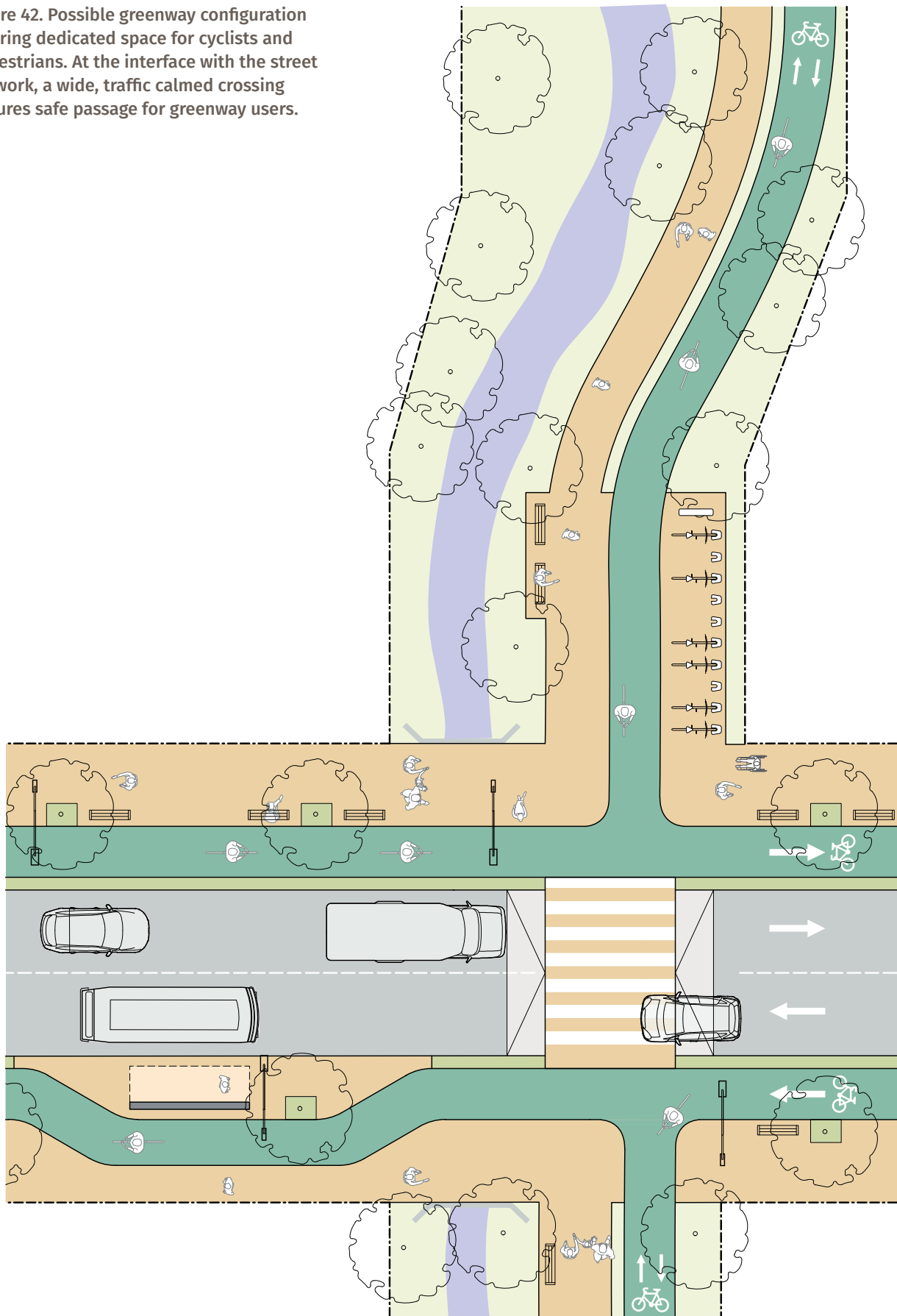

Figure 41. Greenways offer a pleasant environment for walking and cycling.

Figure 42. Possible greenway configuration offering dedicated space for cyclists and pedestrians. At the interface with the street network, a wide, traffic calmed crossing ensures safe passage for greenway users.



4.5. MATATU/BUS STOPS

Well-designed bus stops offer a comfortable, weather-protected waiting area for public transport passengers while leaving clear space for pedestrian movement behind the shelter. Bus bays should be avoided because they increase travel times for public transport users and result in commuters standing in the street while waiting for the bus. However, bus bays may be warranted in some cases where public service vehicles (PSVs) queue for long periods of time or on undivided carriageways, provided that the adjacent footpath and cycle track meet minimum standards.

DESIGN CRITERIA

- ▶ On a street with two or more carriageway lanes per direction, the bus stop should be placed adjacent to the bus' line of travel so that the bus does not need to pull over.
- ▶ On a street with one carriageway lane per direction or at terminal locations, the stop may incorporate a bus bay provided that there is sufficient clear space for walking behind the shelter. The width of the bus bay should be no more than 2.5 m.
- ▶ Shelter with adequate lighting, protection from sun and rain, and customer information.
- ▶ Cycle tracks should be routed behind bus shelters.
- ▶ Bus stops should be provided at intervals of 200-400 m, depending on the level of demand.

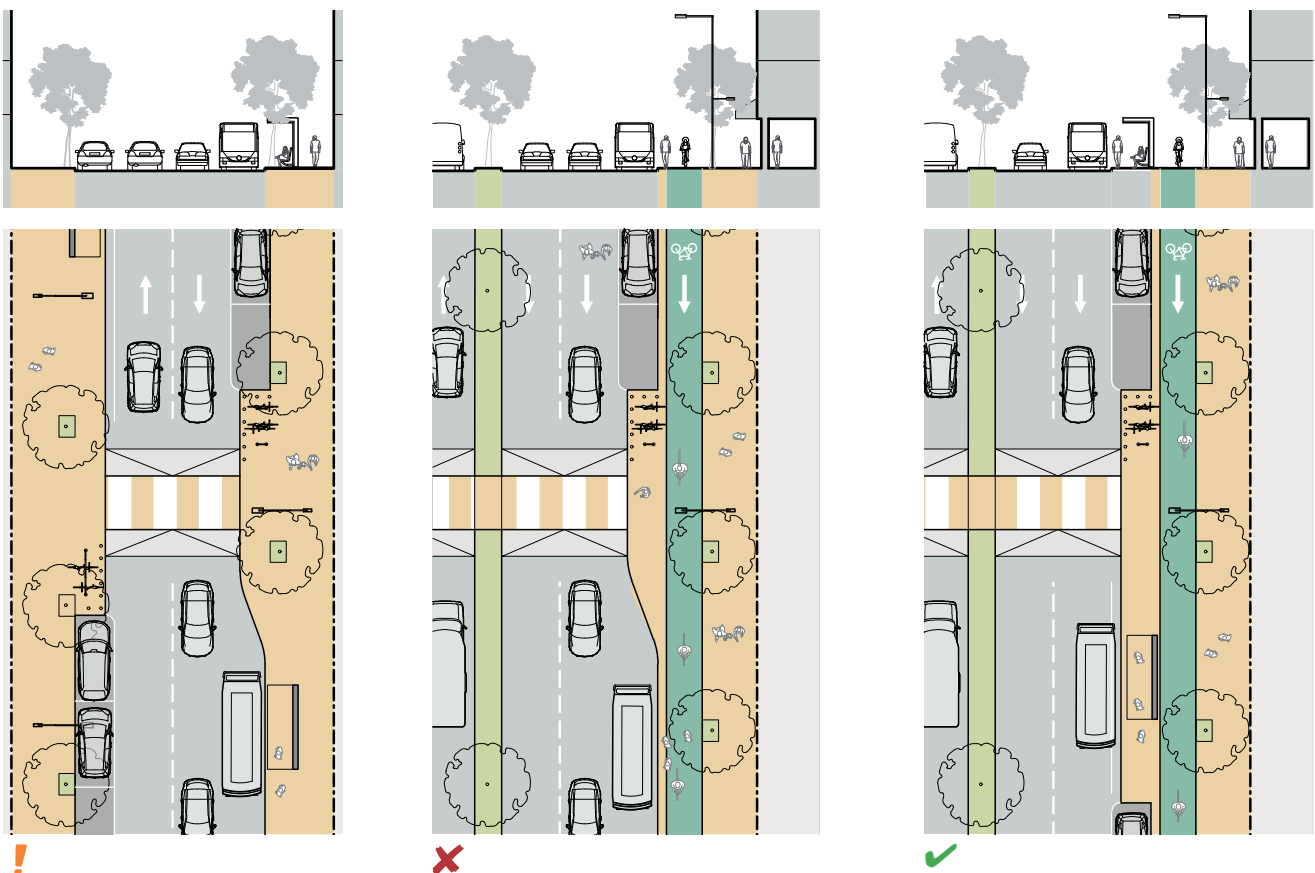

On streets with two-way undivided carriageways, a bus bay may be provided if there is sufficient clear with for walking behind the shelter.

For carriageways with two or more lanes per direction, the bus stop should be placed on a bulbout in the parking lane so that buses do not need to pull over.

Figure 43. Bus shelter placement should be compatible with non-motorised travel and facilitate efficient bus operations.

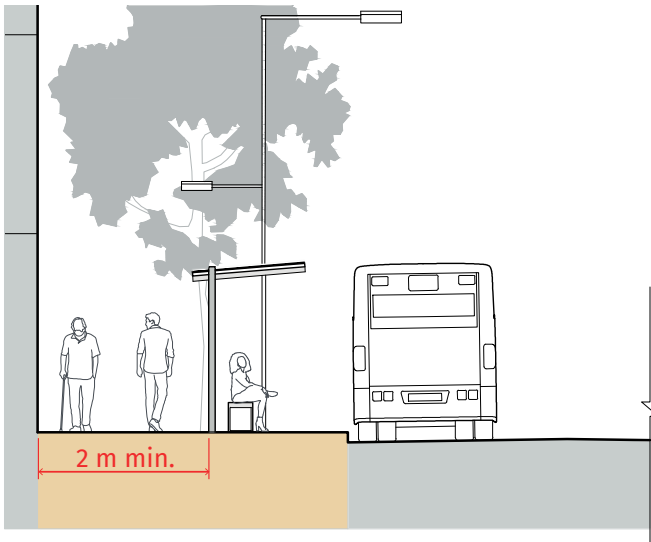

Ensure there is sufficient space for circulation behind the bus shelter.

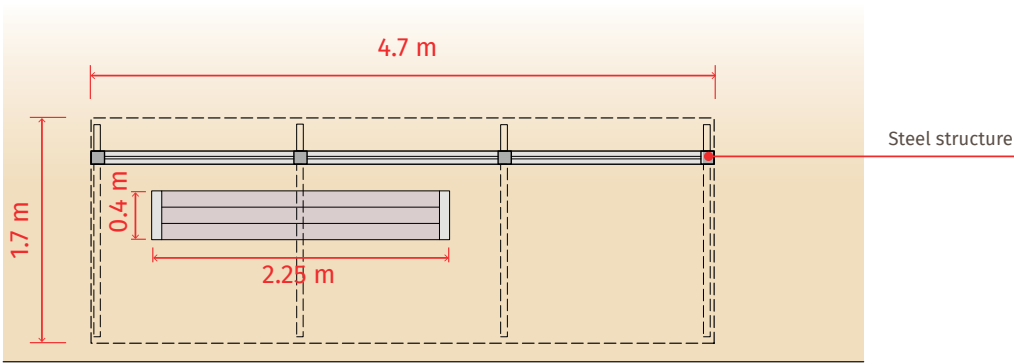

Plan

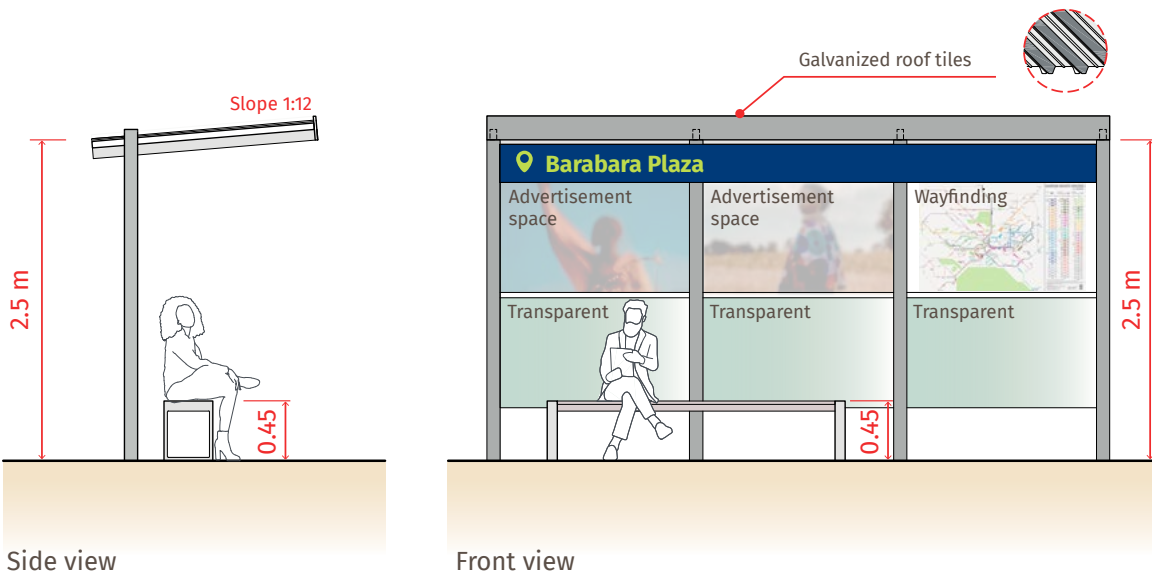

Side view

Front view

Seeing and being seen contribute to a secure environment, especially for women and girls. Transparent materials such as glass or PVC are recommended for the shelter partition panels.

Figure 44. A high-quality bus shelter offers rain protection and shade through opaque roof tiles. Open sides and transparent rear panels improve visibility. The shelter should include seating space and wayfinding information.

4.6. MATATU/BUS TERMINALS

Matatu/bus terminals are points where routes start or end, or stops with significant boarding-alighting activity. Terminals facilitate transfers from one route to another. Terminals also offer facilities such as public toilets and resting areas for bus crews.

DESIGN CRITERIA

- ▶ Minimal walking distances and vertical displacement between platforms. Ensure that the entire facility offers universal access.
- ▶ Avoid bottlenecks. Provide wider spaces where different pedestrian streams intersect.
- ▶ Protection from sun and rain. Roofs should extend above the buses.
- ▶ Ample seating.
- ▶ Complete customer information, including real-time departure information.
- ▶ Adequate lighting to enhance safety and security for passengers.
- ▶ Public toilets with baby changing facilities.
- ▶ Organised vending kiosks.
- ▶ Cycle parking facilities.



Figure 45. High-quality matatu/bus terminals offer protection from sun and rain, seating, and universal access.

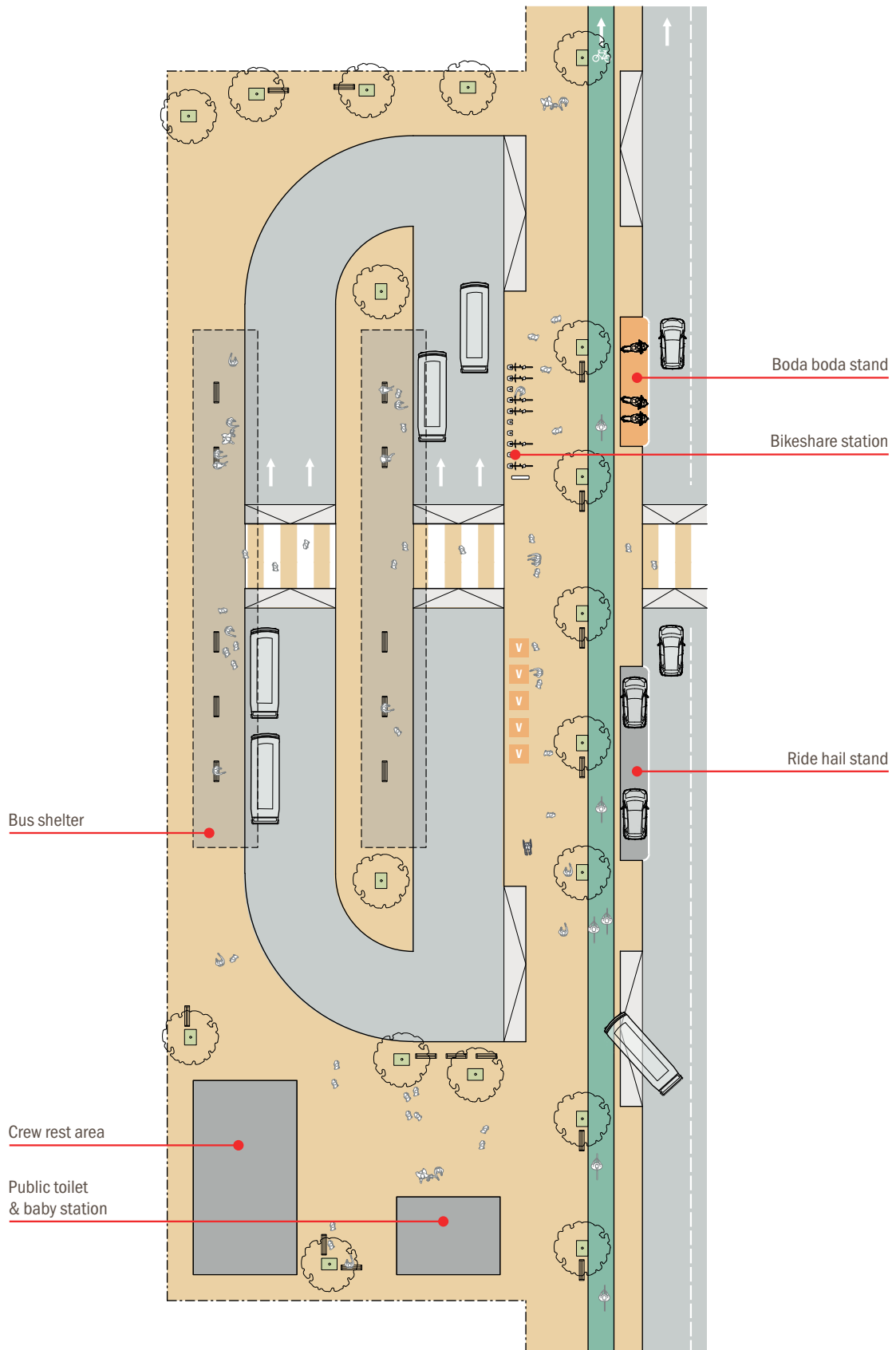

Figure 46. Representative matatu/bus terminal layout.

4.7. BUS RAPID TRANSIT

Bus rapid transit (BRT) can offer high-capacity and high-quality public transport service at a fraction of the cost of rail systems. Realising the advantages of BRT is a function of several design elements, including median-aligned dedicated BRT lanes, platform-level boarding, off-board fare collection, and intersection treatments. BRT also requires safe footpaths, cycle tracks, and crossings to enable convenient passenger access. Besides good physical design, successful implementation of BRT requires effective system management, operations planning, and traffic control. More information on BRT is available in the Nairobi Metropolitan Area Transport Authority's BRT Design Framework.

DESIGN CRITERIA

- ▶ Exclusive BRT lanes with a width of 3.5 provided in the centre of the street. The lanes should be separated from mixed traffic through a physical barrier.
- ▶ Centrally located BRT stations with a minimum width of 4 m, with larger width provided if passenger demand is high.
- ▶ For high-demand corridors, passing lanes, multiple station sub-stops, and express services are needed.
- ▶ Safe pedestrian access via crosswalks elevated to the level of the footpath (+150 mm) across mixed traffic lanes. The BRT lanes should be raised to +150 mm for the length of the station, with a ramp slope of 1:100 for buses.
- ▶ Stations should be placed at least 40 m from intersection stop lines to allow sufficient space for bus and mixed traffic queues.
- ▶ Two-phase intersections to minimise delays for buses.
- ▶ Maximum grade of 5% for BRT lanes and 2% at stations.



Figure 47. BRT offers fast, reliable public transport service.

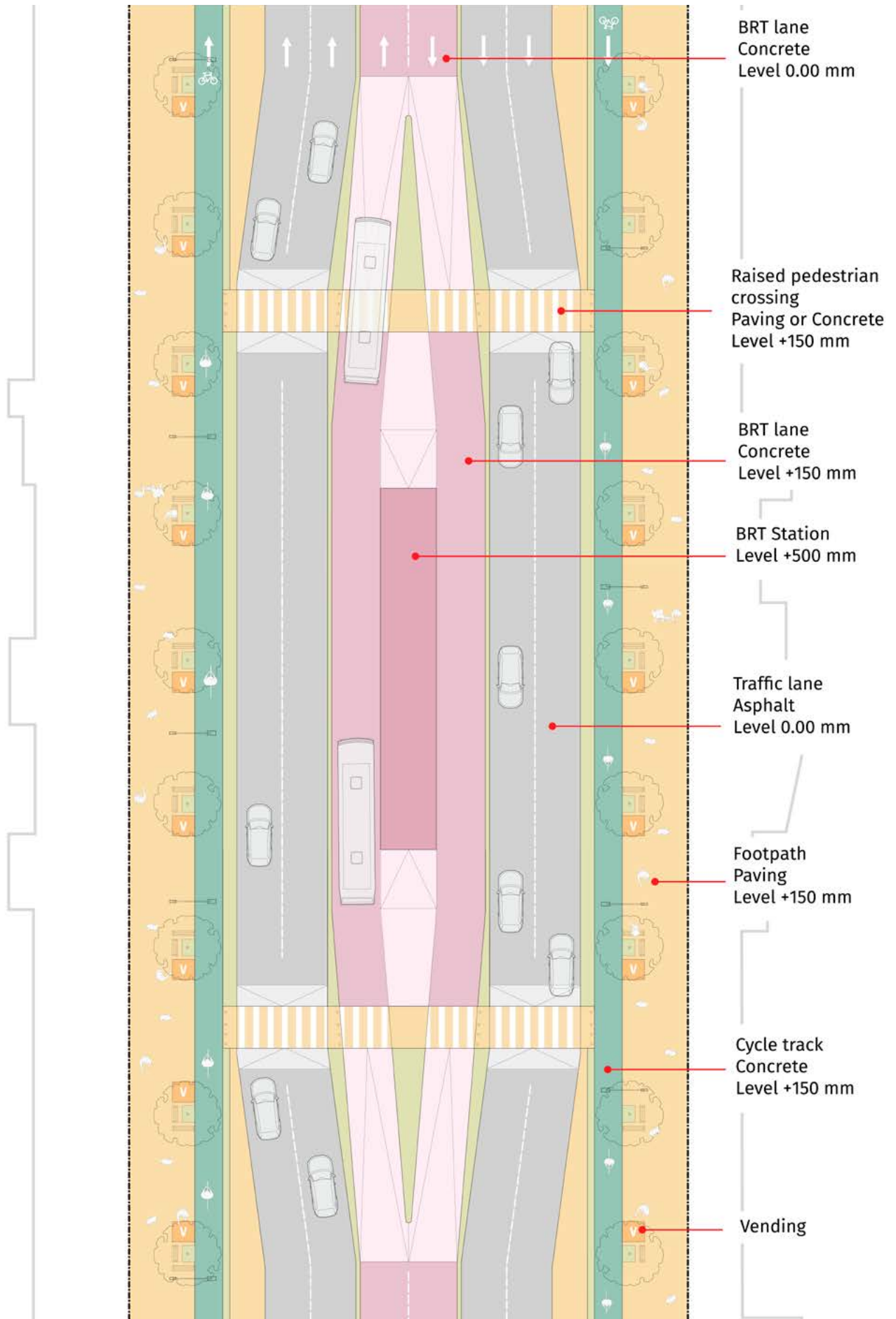

Figure 48. BRT offers fast, reliable public transport service.

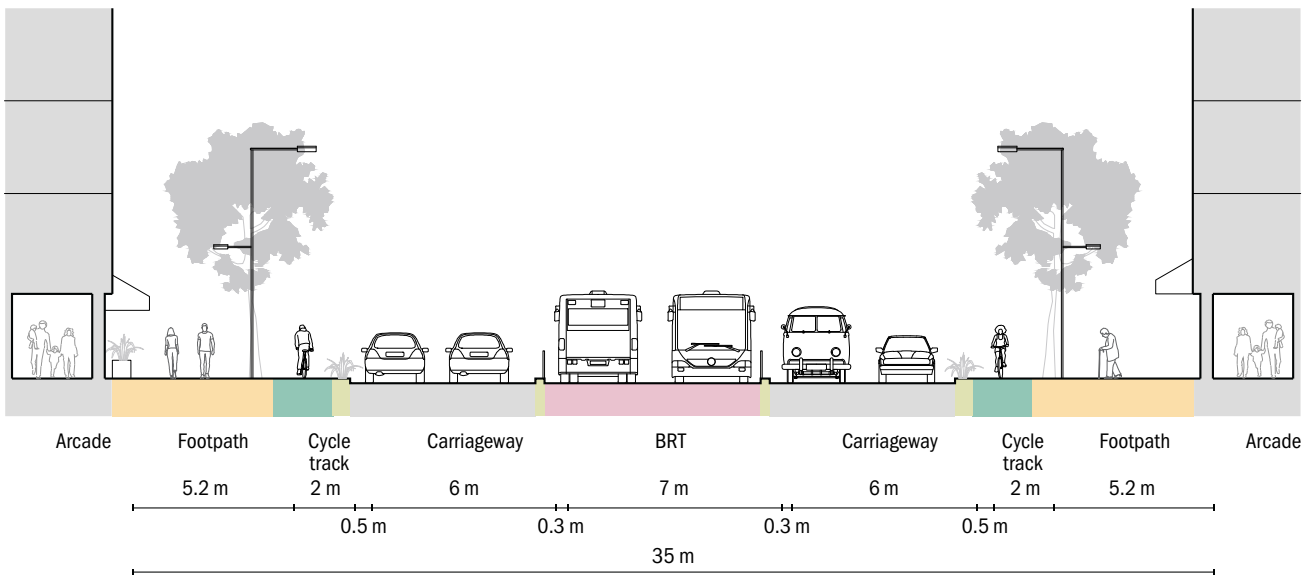
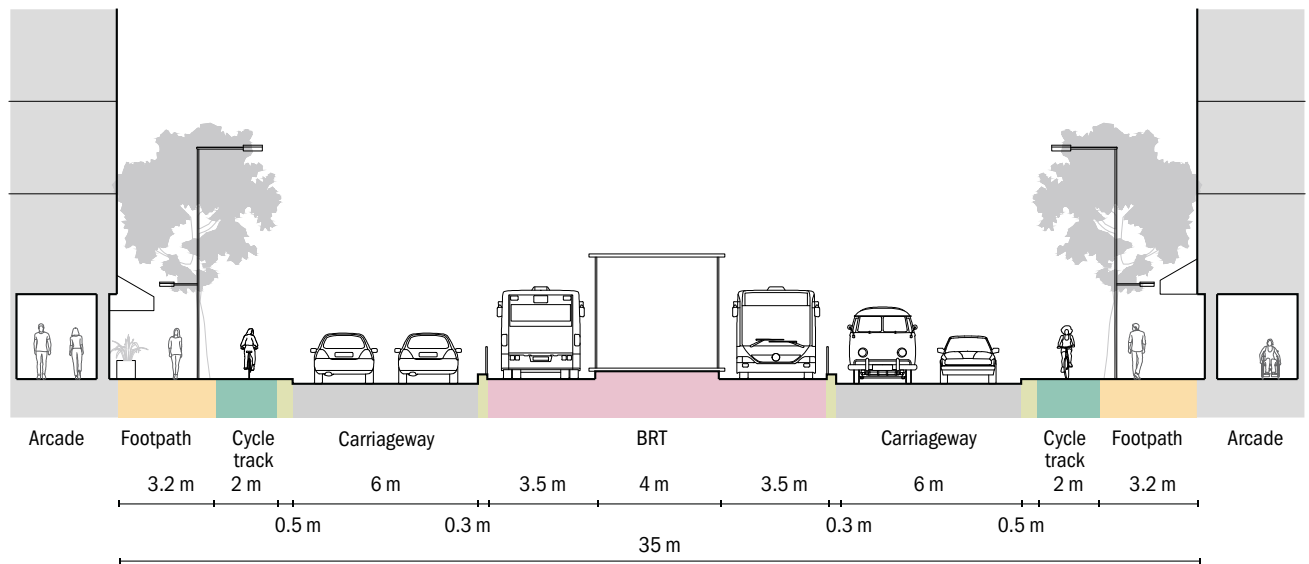

Figure 49. This typical BRT alignment with a single lane per direction can accommodate passenger volumes of up to 6,000 passengers per hour per direction (pphpd) with 12 m buses and 10,000 pphpd with articulated buses.



Figure 51. BRT can be implemented on narrow streets by allocating the full right-of-way to buses, cyclists, and pedestrians.



Figure 50. Passing lanes can increase the passenger capacity of a BRT system by allowing express buses to overtake local buses at certain stations.

4.8. CARRIAGEWAYS

Street space should be allocated to the carriageway after adequate usable space has been reserved for walking, cycling, trees, public transport (including BRT if the street falls on the city's rapid transit network), and street vending. Otherwise, such activities will spill over onto the carriageway. Carriageway width is not determined by available ROW.

The carriageway should be designed for appropriate speeds suited to the street's role in the network. Carriageway designs need to ensure safety for vehicle users as well as for pedestrians and cyclists.

When carriageways become congested, they can no longer fulfil their role of providing for vehicle mobility. In the face of growing traffic volumes, it is essential to use the available road space more efficiently by investing in public transport and active mobility. Congestion also can be addressed through parking pricing and other travel demand management measures to reduce the number of vehicles on the street. These measures reduce congestion, thereby improving conditions for the remaining users.

DESIGN CRITERIA

- ▶ A carriageway lane width of 3.0-3.25 m is appropriate for streets in urban areas in order to encourage safe driving speeds and facilitate safe interactions with other street users. Carriageways on urban streets should not be wider than three lanes per direction. In industrial zones, a 3.5 m lane width is acceptable.
- ▶ Design speeds should reflect the surrounding urban context, especially the level of pedestrian and cyclist activity.
- ▶ Superelevation is generally not used on streets with speeds of 70 km/h or below in urban areas. It negatively impacts drainage, footpaths, adjacent properties, intersections, and vehicle speeds. Instead, streets are to be crowned with maximum 2.0% cross-slope (2.5% where there is heavy rain).
- ▶ Vertical curves are to follow the natural grade of the land and/or match adjoining properties. Where vertical curves impact stopping sight distance, lower driver speeds along the affected sections.
- ▶ Horizontal curves are designed to manage vehicle speeds (see Table 6). Where a smaller right-of-way is available, reduce the horizontal radius in order to ensure continuity in cycle tracks and footpaths.
- ▶ Maximum grade of 5%, except in cases of geographical constraints.

Table 6. Horizontal curves¹

Design speed (km/h)	Horizontal curve radius (m)
20	10
30	28
40	62
50	120

¹ AASHTO. (2018). A Policy on Geometric Design of Highways and Streets. Table 3-13.

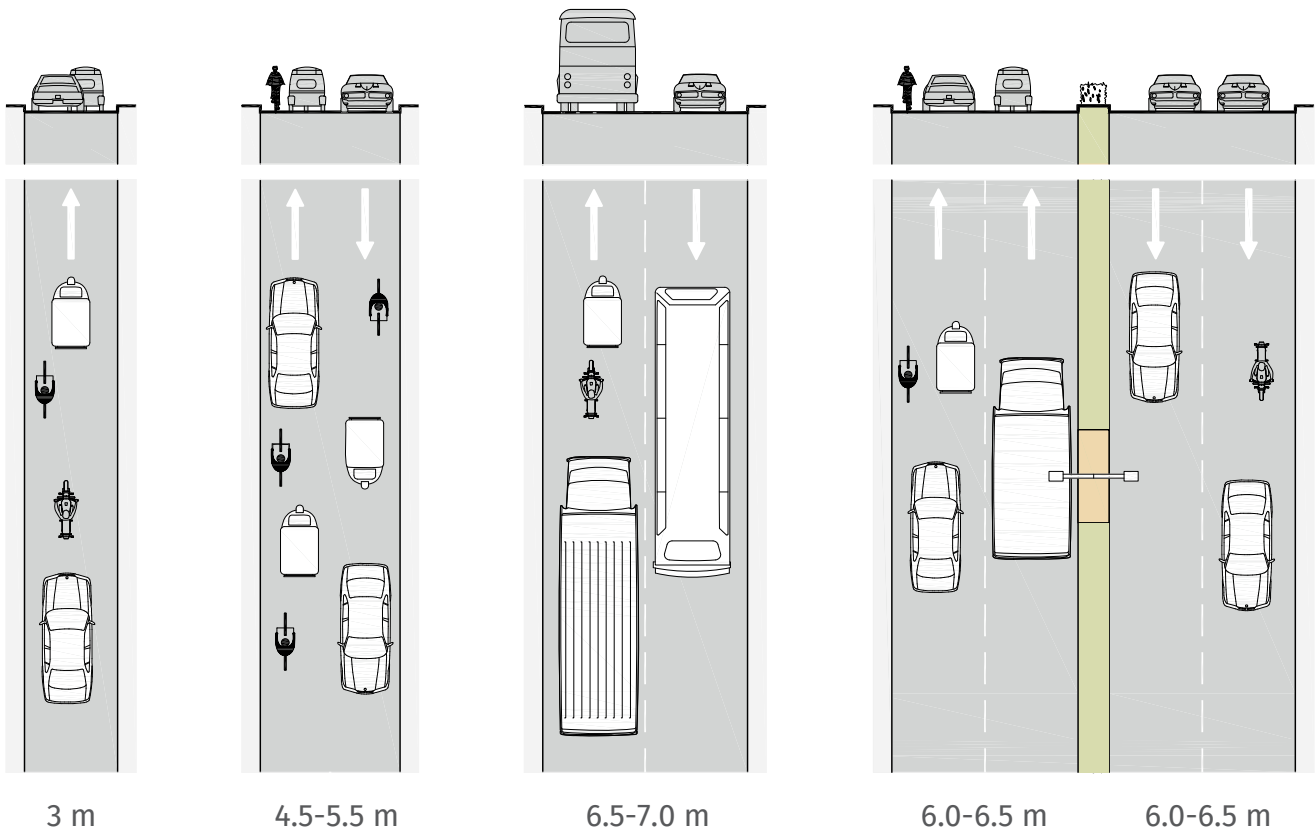

For a local street with shared space, the optimum width for a carriageway is 3 m for one-way movement and 4.5-5.5 m for two-way movement.

For local and collector streets that need to accommodate buses and trucks, the width of a two-way carriageway can vary between 6.5 and 7.0 m, depending on the volume of heavy vehicles.

In arterial streets, the optimum width of a two-lane carriageway is 6.0-6.5 m, and that of a three-lane carriageway, 9.0-9.75 m.

Figure 53. Appropriately sized carriageways can encourage safe driver behaviour.



Figure 54. In urban areas, 3.25 m lanes can accommodate movement of large vehicles at moderate speeds.

4.9. TRAFFIC CALMING

Well-designed traffic calming improves safety by reducing the speed and potentially also the volume of motor vehicles. Traffic calming elements are particularly important in places where large numbers of children are present, such as schools, parks, and residential areas. Some traffic calming elements, such as speed humps and speed tables, are easy to implement, and can be deployed quickly as a solution to road safety challenges.

Traffic calming slows down vehicles through one of the following mechanisms: vertical displacement, horizontal displacement, real or perceived narrowing of the carriageway, material/colour changes that signal conflict points, or the complete closure of a street. Traffic calming can take different forms depending on the context, and is most effective where two or more mechanisms are combined. Typical forms of traffic calming include speed humps and raised pedestrian crossings, both of which rely on vertical displacement to reduce speeds.

DESIGN CRITERIA

- ▶ Traffic calming can take different forms depending on the context, and is most effective where two or more mechanisms are combined. Traffic calming can be applied near intersections or every 80-120 m in stretches where speeds need to be controlled, such as school zones (streets within 100 m of schools), residential areas, or locations with high foot traffic.
- ▶ Vertical-deflection devices include raised crossings, speed humps, and raised intersections.
- ▶ Raised crossings should match the level of the adjacent footpath—typically 150 mm. A flat top design is preferred, with allowances for drainage at the kerb. The critical dimension is the ramp slope:
 - 1:6 yields 10 km/h
 - 1:8 yields 15 km/h
 - 1:10 yields 20 km/h
 - 1:12 yields 25 km/h
 - 1:14 yields 30 km/h
- ▶ Speed humps should follow a sinusoidal shape to improve comfort for cyclists.
- ▶ Rumble strips are uncomfortable for cyclists and should be avoided on urban streets.
- ▶ Horizontal-deflection devices include mini-roundabouts, chicanes, and islands. Design varies but the objective is to reduce speed to 10 km/h below the speed limit.

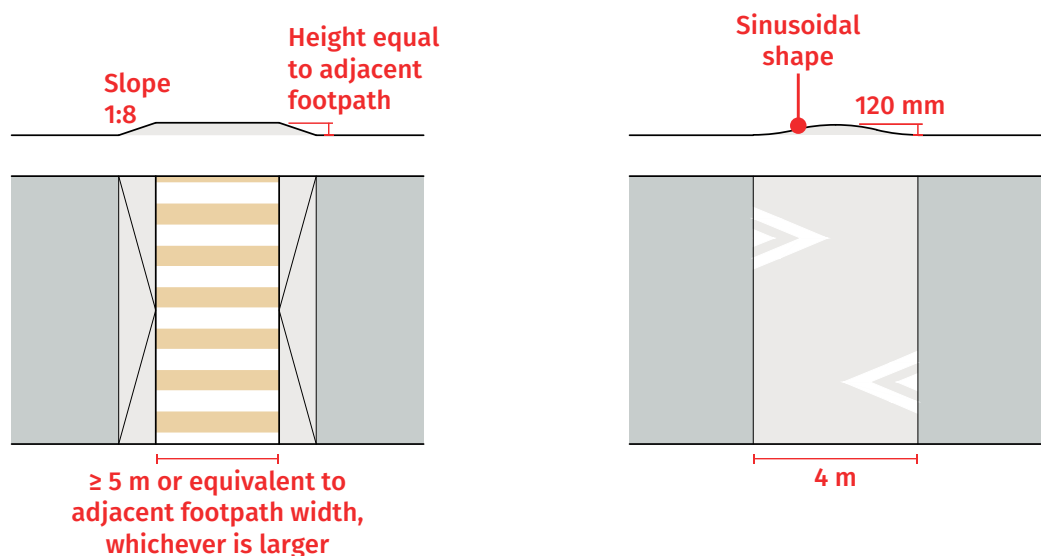

Figure 55. Vertical deflection devices include raised crossings (left) and speed humps (right).

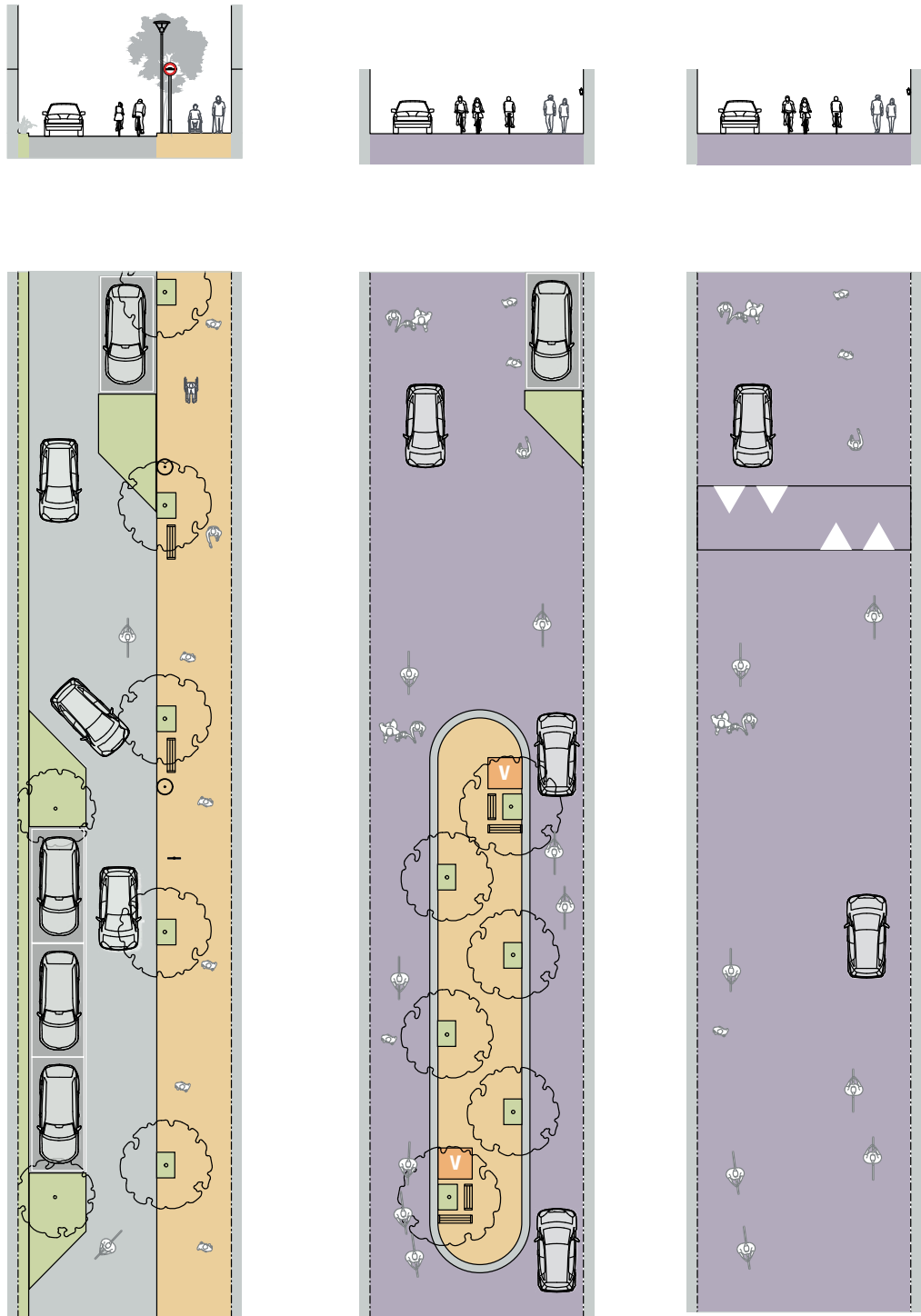

Figure 56. Traffic calming options include horizontal displacement through a meandering carriageway (left) or shared space (middle) and vertical displacement in the form of a speed hump (right).

4.10. LANDSCAPING

Landscaping improves the liveability of streets. It plays a functional role in providing shade to pedestrians, cyclists, vendors, and public transport passengers. Landscaping also enhances the aesthetic qualities of streets and helps to control erosion.

DESIGN CRITERIA

- ▶ Existing trees are to be retained in the course of street improvement projects.
- ▶ Minimum distance between trees to provide continuous shade, depending on the individual trees' canopy size and shape. A typical interval is 5-10 m between trees.
- ▶ Tree locations should be coordinated with the position of street lights.
- ▶ Tree pits should have dimensions of at least 1.5 m by 1.5 m to accommodate the trunk and root structure at full maturity. On narrow footpaths, 1 m wide tree pits are acceptable. On wider footpaths, the preferred permeable area for a tree pit is 5 sq m.
- ▶ Hume pipes can lower the level at which roots spread out, thereby reducing damage to road surfaces and utilities.
- ▶ Trees with high branching structures are preferable.
- ▶ Medium-height vegetation should be trimmed next to formal crossings to improve the visibility of pedestrians and cyclists.
- ▶ Indigenous, drought-resistant species are preferable.



Figure 57. Landscaping, especially tree cover, can improve comfort for pedestrians and cyclists while enhancing the beauty of the streetscape

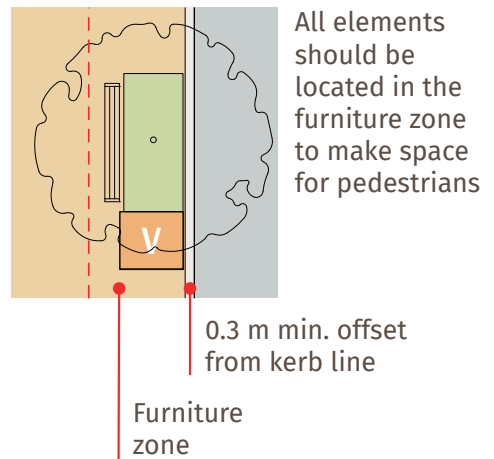
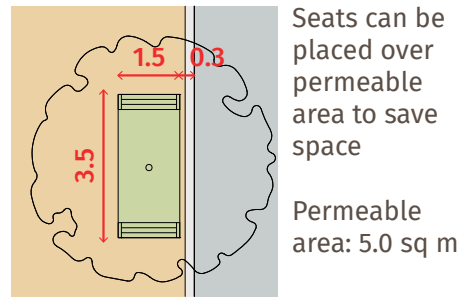
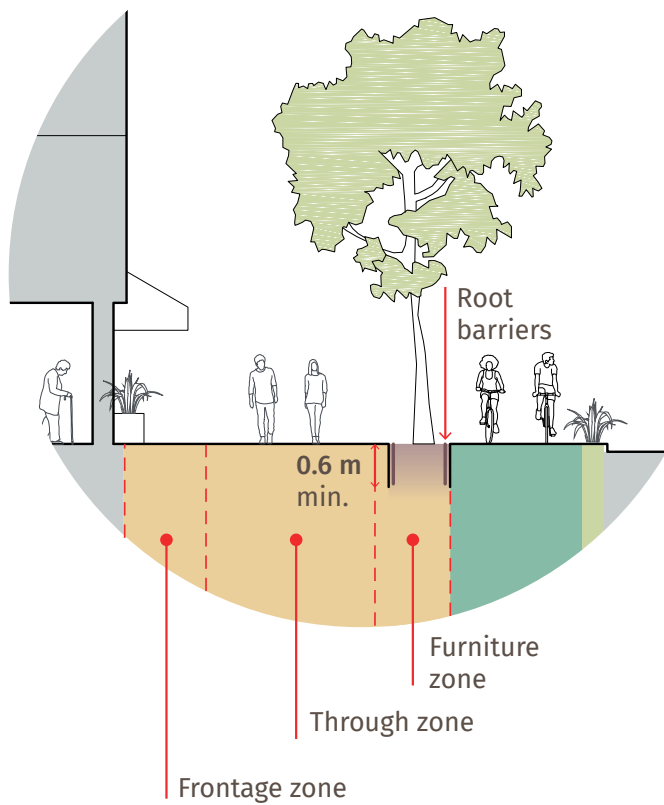
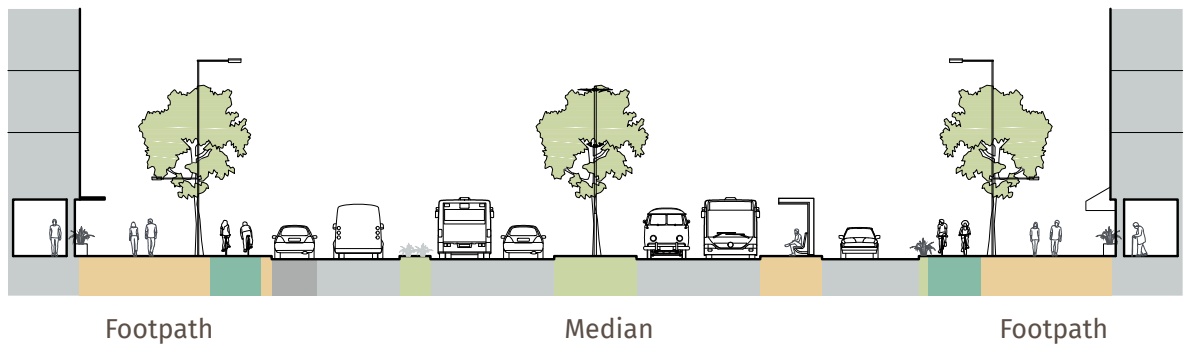

Figure 58. Every footpath and cycle track should have continuous shade from trees. Trees should be aligned in order to improve compatibility with underground utilities. Additional tree lines may be included in medians to further enhance the streetscape.

4.11. VENDING

Street vending provides essential goods and services to a wide range of population groups. It also makes public space safer by contributing “eyes on the street,” particularly on streets lined with compound walls. If designed properly, vending can be accommodated in the streetscape without interfering with other uses. Some streets with high pedestrian volume can be closed to traffic and be fully pedestrianised in the evening to accommodate vending activities.

DESIGN CRITERIA

- ▶ Street vendors should be accommodated where there is demand for their goods and services—near major intersections, public transport stops, parks, and so on.
- ▶ Supporting infrastructure, such as cooperatively managed water taps, electricity points, trash bins, and public toilets, should be provided.
- ▶ Vending areas should be positioned so as to ensure the continuity of cycle tracks and footpaths. The furniture zone of the footpath or a bulb out in the parking lane are ideal locations.



Figure 59. Footpaths should be designed such that there is sufficient space for vending outside of the pedestrian zone.

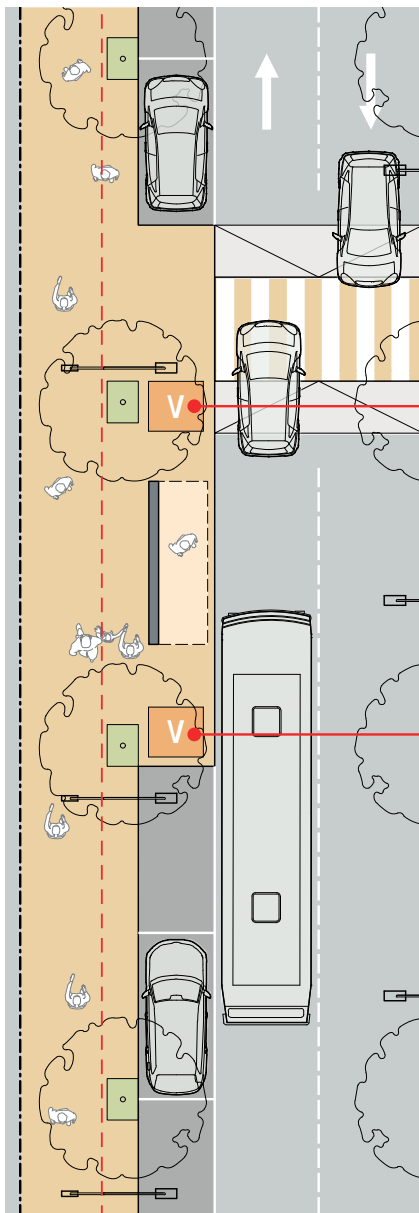

Vending spaces should be placed in a bulbout in the parking lane (as pictured here) or in the furniture zone, leaving clear space for pedestrian movement.

Vendors tend to be attracted to spaces under trees or close to bus stops. Vendors also prefer spots that are visible to passersby.

1.2 x 1.2 x 0.45 m min.

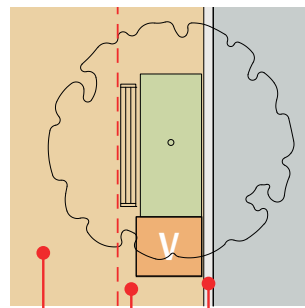

Both the seat and vending stalls should be located in the furniture zone

0.3 min. offset from kerb line

Furniture zone

Through zone

Raised concrete platform can display the merchandise safely and serve different functions

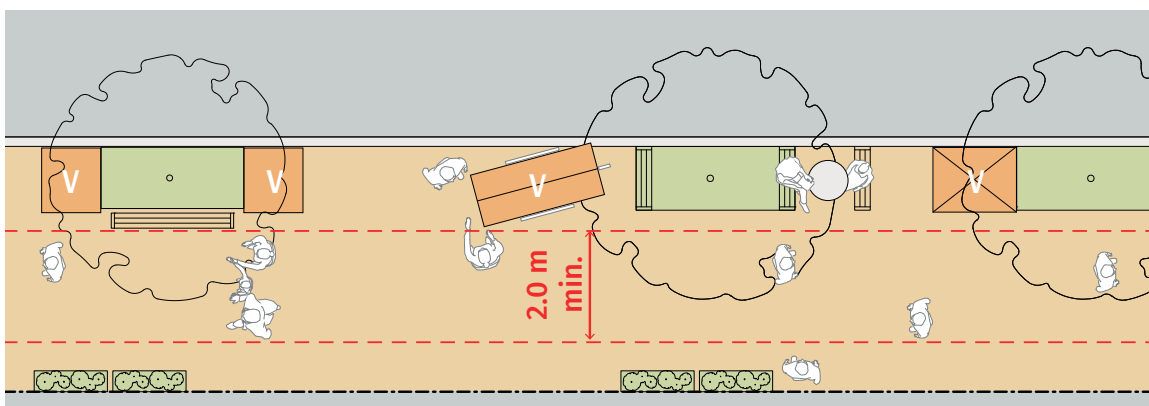
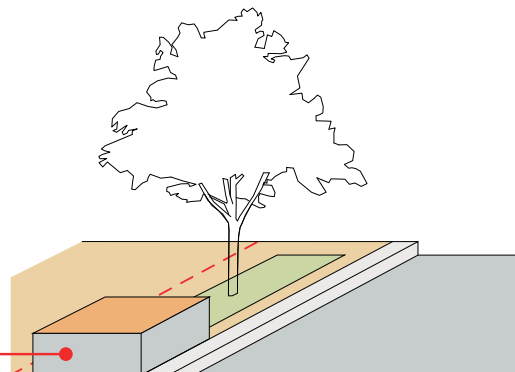

Furniture zone

Through zone

Frontage zone

2.0 m min.

Figure 60. Street vending layouts.

4.12. STREET FURNITURE

Street furniture provides people places to sit, rest, and interact with each other. Street furniture also includes services-related infrastructure, such as trash cans, street vending, toilets, and signage. Vending stands, tables, roofs, and water taps can support the formalisation of street vending and promote better sanitary conditions. Finally, other street furniture, such as way-finding signs and bus stops, provides information.

To guide tourists and other visitors who may not be familiar with a city, it is useful to provide wayfinding information to pedestrians containing relevant information and directions to key places within the city e.g. library, museum, nearest bus stop etc. Pedestrian information signs should be located at popular pedestrian meeting points and at intersections. Signs should be positioned in the furniture zone to allow for adequate visibility without obstructing pedestrian movement.

DESIGN CRITERIA

- ▶ Furniture and amenities should be located where they are likely to be used. Furniture is required in larger quantities in commercial hubs, market areas, crossroads, bus stops, BRT stations, and public buildings.
- ▶ Most street furniture, especially benches and tables, should be placed where it receives shade.
- ▶ Furniture should be located where it does not obstruct through movement.
- ▶ On streets with large numbers of pedestrians and commercial activity—especially eateries—trash bins should be provided at regular intervals (i.e., every 20 m).
- ▶ Traffic signs should be located at a height of at least 2.2 m above the ground.



Figure 61. Street furniture offers spaces to rest and interact.

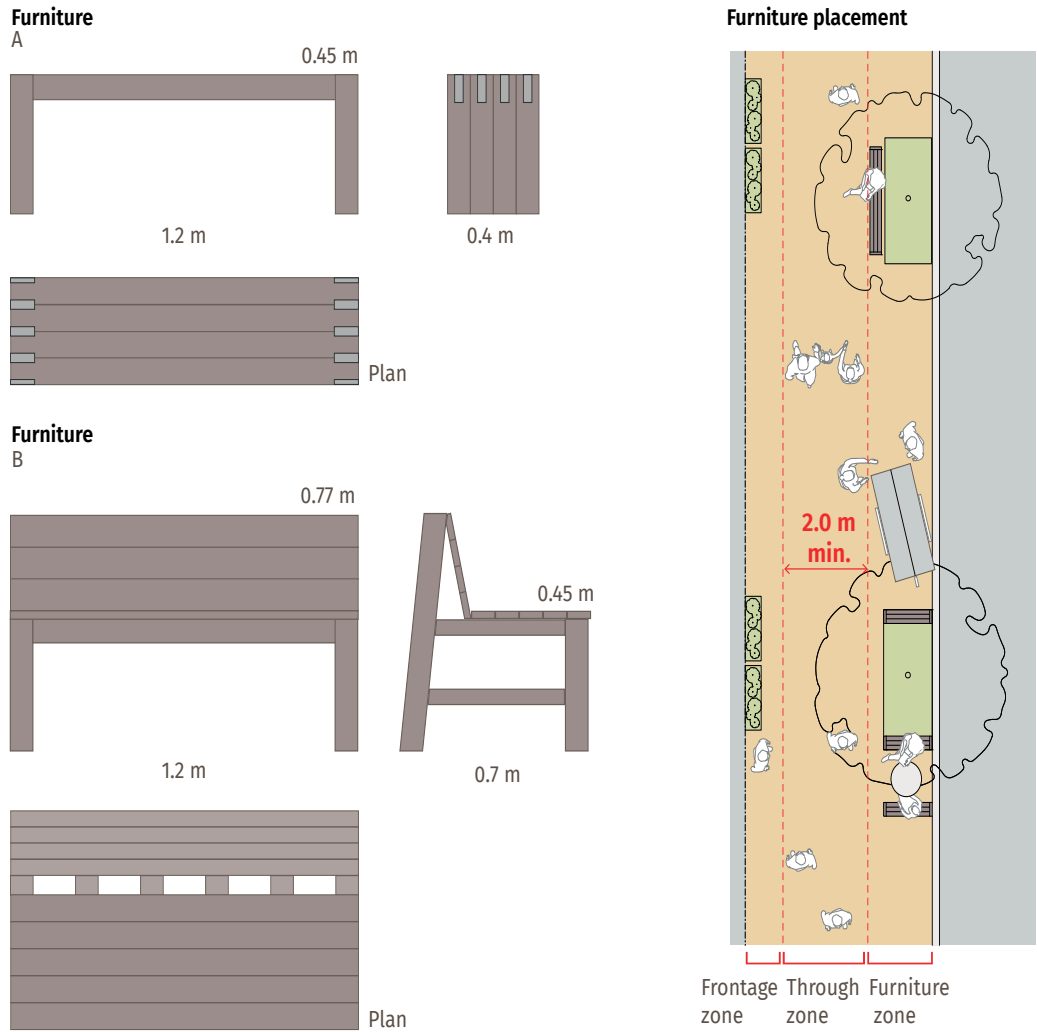

Figure 62. Furniture design and placement.

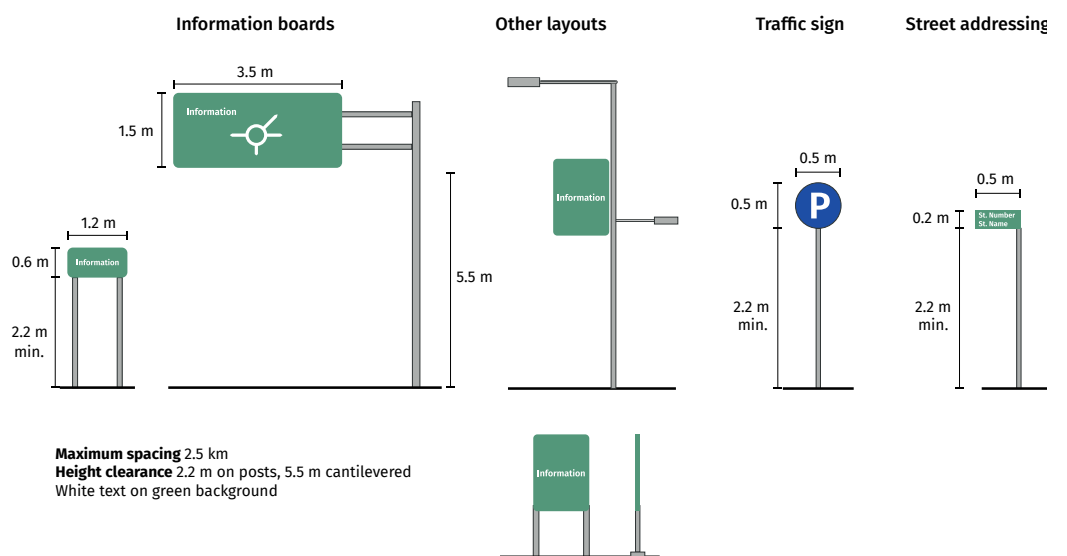
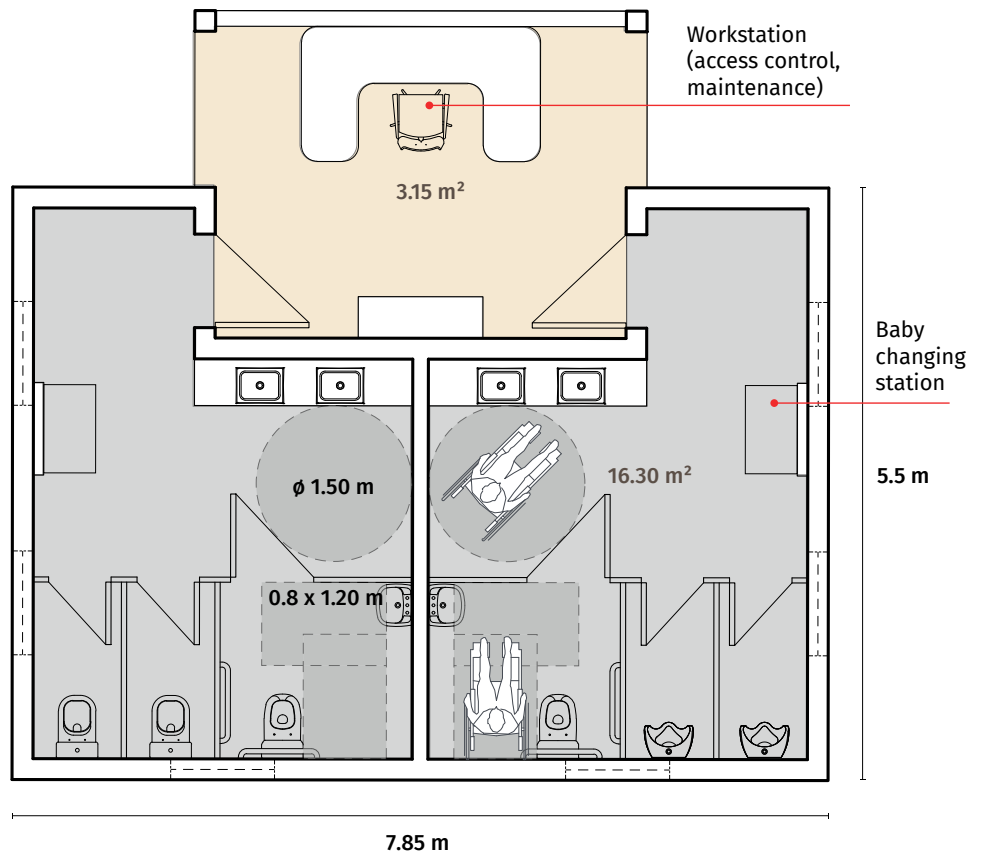

Figure 63. Signage design.

Public toilet layouts
 Female / male stalls
 52.15 m²



Unisex stall
 19.50 m²

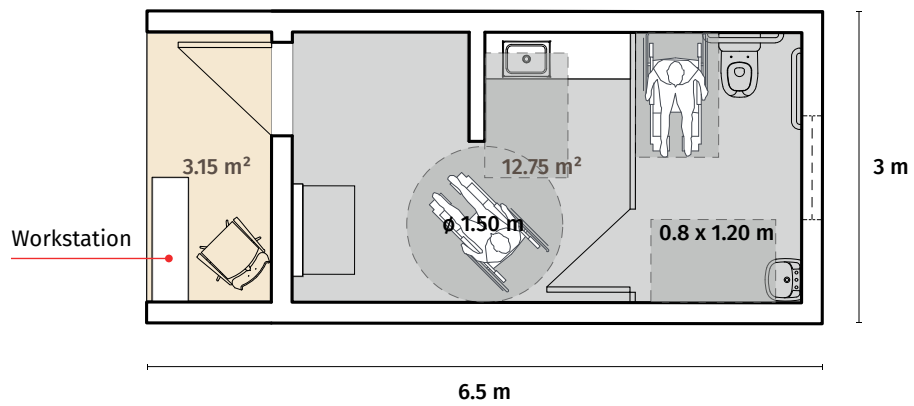

Figure 64. Design of public toilets.

4.13. SERVICE LANES

Service lanes improve safety and throughput by segregating property access points and parking from the main carriageway. Service lanes can increase the mobility function of the main carriageway while also maintaining liveability for non-motorised road users. They also reduce interruptions in cycle tracks, and with reduced speeds because of traffic calming, service lanes can function as slow shared spaces. Service lanes that are too wide encourage fast driving. In addition, wide service lanes invite encroachment by shops, parked vehicles, or street vendors. Therefore, moderate service lane widths are needed to ensure safe user behaviour.

DESIGN CRITERIA

- ▶ A service lane should be between 3 and 3.5 m wide for a single lane and 5.5-6.0 m for two lanes.
- ▶ Service lanes should contain traffic calming elements to maintain safe driving speeds.
- ▶ A service lane need not be continuous, lest it become an alternative to the main road.

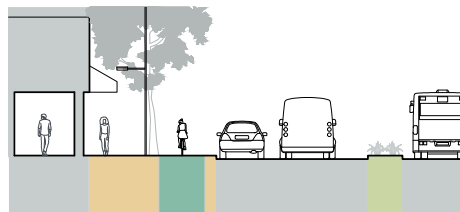

Service lane



Parking lane Service lane

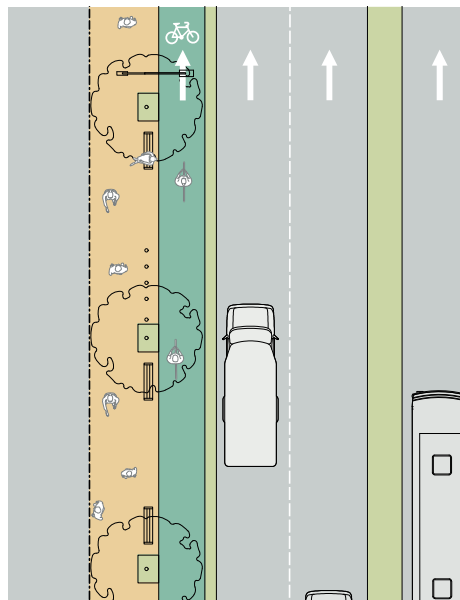

- ✗ Service lanes should not be designed to favour high driving speeds. Instead, through traffic, including matatus and buses, can use the carriageway.

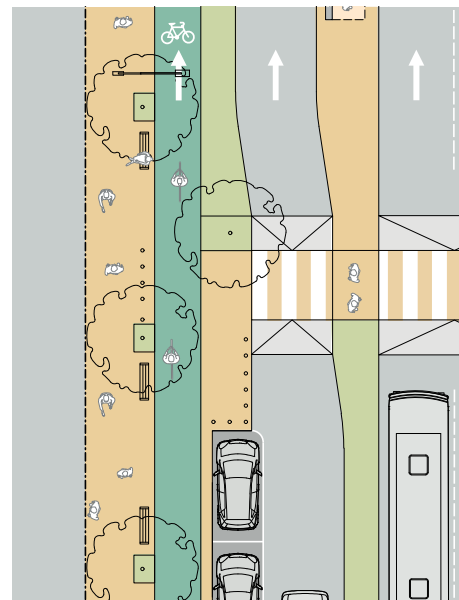

- ✓ Service lanes with a single-lane configuration, frequent crossing points, and bulb-outs facilitate moderate speeds.

Figure 65. Service lanes should be designed for slow-speed access to adjacent properties.

4.14. STREET LIGHTING

Well-designed street lighting enables motor vehicle drivers, cyclists, and pedestrians to move safely and comfortably by reducing the risk of traffic crashes and improving personal security. Lighting should illuminate not only the carriageway but also the spaces for walking and cycling.

DESIGN CRITERIA

- ▶ Height
 - Typical: 8-10 m
 - Along footpaths, paths, and cycling facilities: 4.5-6 m
 - Along wider streets (> 24 m ROW): 10-12 m
- ▶ Spacing: 2.5-3.0 times height
- ▶ Typical lighting levels
 - Intersections and other conflict areas (crossings): 8-34 lux depending on size and activity
 - Typical streets: half that of intersections
 - Shared streets: 10-20 lux depending on activity
 - Footpaths and cycling facilities: 2-10 lux depending on location
 - Paths and trails: 5-10 lux
 - Stairs, ramps, bridges, tunnels, entrances: 10-50 lux
- ▶ The placement of street lighting should be coordinated with other street elements so that trees or advertisement hoarding do not impede proper illumination.
- ▶ Light poles should be located in the furniture zone and/or on medians so as not to interfere with the movement of pedestrians and cyclists.



Figure 66. Continuous lighting improves safety and personal security.

► The following lighting systems should be considered:

- Twin central: Used on dual carriageways.
- Opposite: Used on dual carriageways where twin central lights are not suitable due to narrow median width
- Staggered: Used on single carriageways.
- Single-sided: Used on single carriageways.
- Combined twin central and opposite: Used on wider streets with dual carriageways and service lanes.

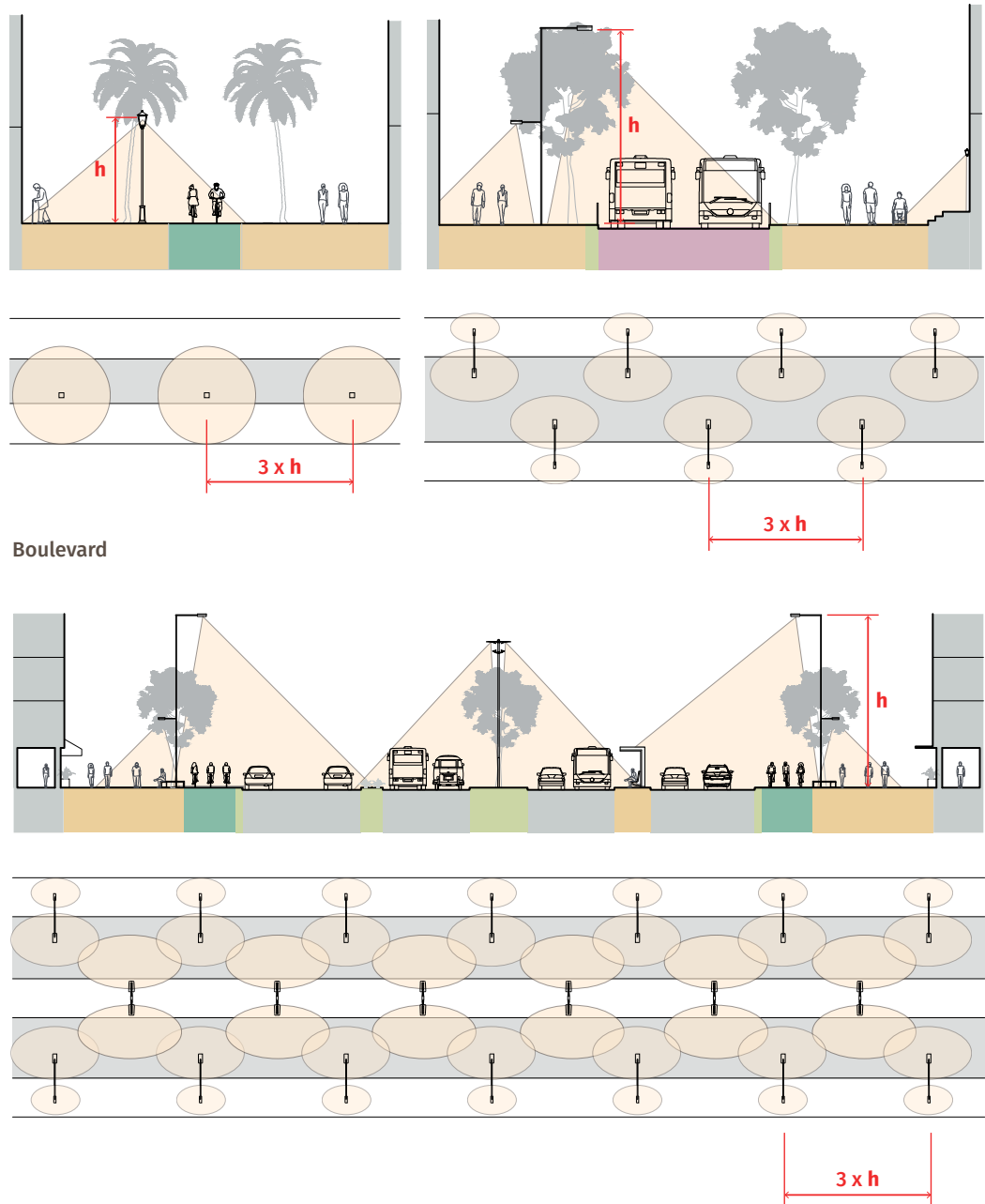

Figure 67. Street lights typically illuminate an elliptical area. As a rule of thumb, the longitudinal dimension is equivalent to three times the pole height, and horizontal dimension is slightly longer than the pole height.

4.15. ON-STREET PARKING

In general, valuable street space should be used for wider walkways, trees, cycle tracks, cycle parking, vending, and social gathering space rather than parking. On-street parking may be allowed on streets where all the other requirements for public transport and non-motorised travel have been met. Bike parking racks should be provided on each block in commercial areas. Some parking spaces can be designated for boda boda parking.

DESIGN CRITERIA

- ▶ Parking areas should be allotted after providing ample space for pedestrians, cyclists, trees, and street vending.
- ▶ Parking bay width of 2.0 m width for taxi stands and 2.2 m in commercial areas.
- ▶ Tree pits can be integrated in a parking stretch to provide shade. Otherwise, shaded street elements, such as footpaths, may be encroached by parked vehicles.
- ▶ Within 10 m of intersections, parking lanes should be discontinued to reduce conflict and to give additional vehicle queuing space.
- ▶ Dedicated cycle parking should be provided at regular intervals in commercial districts. The rack should support the frame and should allow the cyclist to secure one wheel and the frame with a U-lock. The rack should be placed in the furniture zone of the footpath to avoid obstructing pedestrian flow.
- ▶ Provide designated parking spaces for boda bodas at established stage locations.

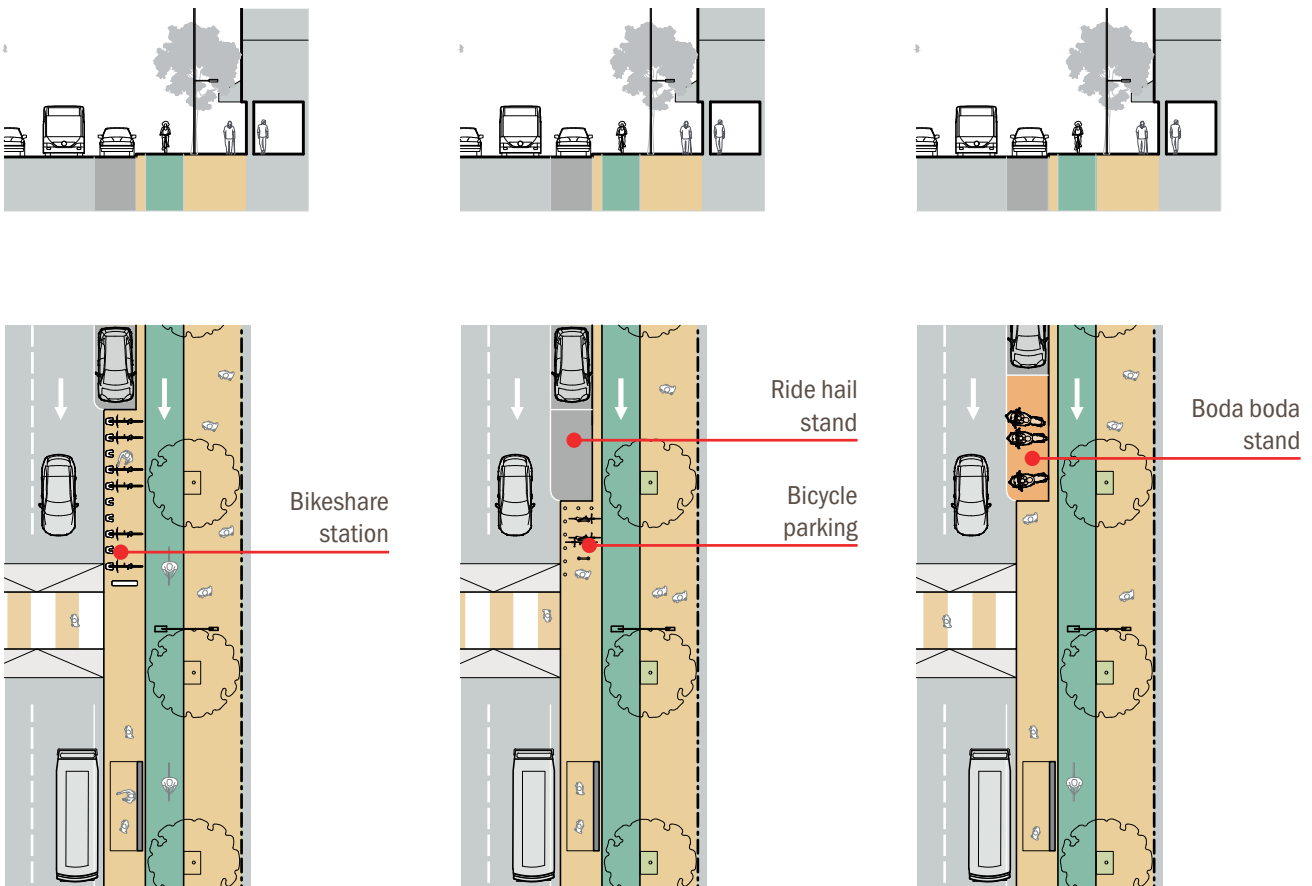
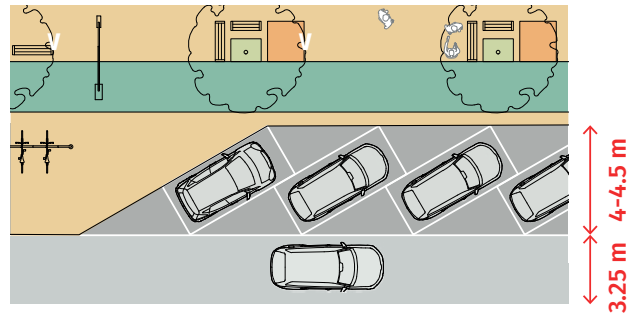
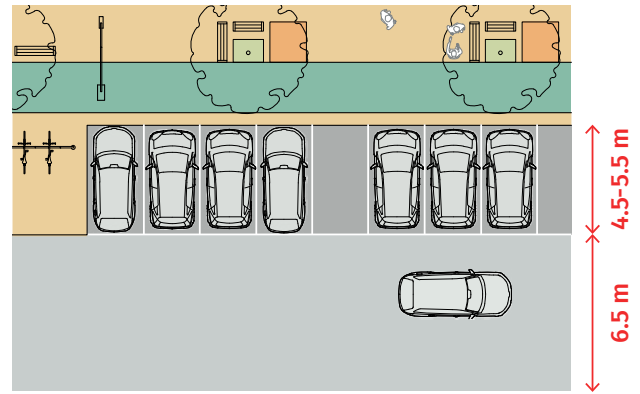
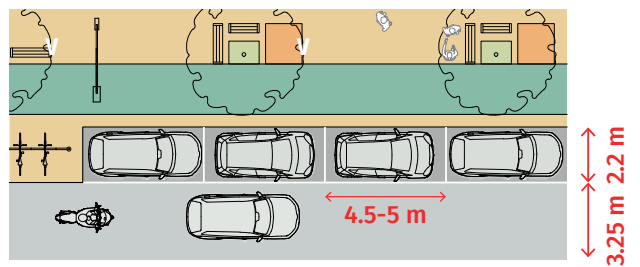

Figure 68. Parking lanes can accommodate bikeshare stations, bicycle parking, ride hail stands, and boda boda stands.



✗ Figure 70. Angular and perpendicular parking occupy a large portion of the right-of-way. Exiting the parking bay can be dangerous because drivers have limited visibility.



✓ Figure 69. Parallel parking for cars is preferred over angular or perpendicular parking because it saves space and is safer while exiting the parking bay. The standard width for a parallel parking lane is 2.2 m in commercial areas and 2.0 m for taxi stands. Larger parking slots can be provided for persons with disabilities.

4.16. STORM WATER DRAINAGE

Adequate and efficient storm water drainage prevents water logging, erosion, and pavement failure. Many streets presently place pedestrians and cyclists at the lowest point of the cross section, forcing them to wade through water and mud during the rainy season. Instead, footpaths and cycle tracks should be raised to permit storm water runoff.

Closed storm water drains are preferred to open drains in the urban environment. Open drains occupy considerable road width that can be used for NMT facilities and landscaping. Open drains also create an uncomfortable walking environment for pedestrians and cyclists. It is often assumed that open drains are easier to maintain, but open drains in Kenyan cities also accumulate debris and silt in the absence of proper maintenance. Both open and closed drains require regular cleaning, especially before rainy seasons.

DESIGN CRITERIA

- ▶ The lowest point in the cross section should occur on the carriageway. Cycle tracks, footpaths, bus stops, and street vending areas should be at a higher level.
- ▶ 1:50 camber for footpaths and cycle tracks.
- ▶ Drain surfaces should be at grade with the surrounding street surface unless provided in landscaped areas. Gratings should be designed so that they do not catch cycle wheels.
- ▶ The following types of drains are preferred in order to maximise the area available for NMT:
 - Underground drain with catch pits at regular intervals. Catch pits have an extra depth of 0.5 m to collect debris.
 - Rectangular concrete channel covered with precast slab covers. Care must be taken to ensure that the covers are installed properly, creating a continuous surface.
- ▶ More environmentally benign approaches such as landscaped swales improve groundwater recharge, reduce storm water runoff, and improve the overall liveability of a street.
- ▶ The gradient of the storm water drain should be such that flow velocity is sufficiently fast to prevent deposition of solids.
- ▶ Storm water design standards can be found in the Standard Drainage Structures Manual.

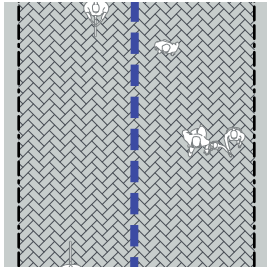
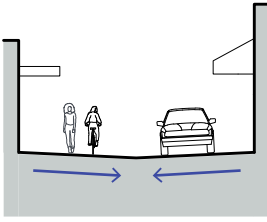

Figure 73. On narrow local streets with shared space, surface drainage is sufficient.

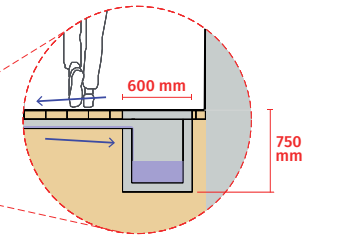
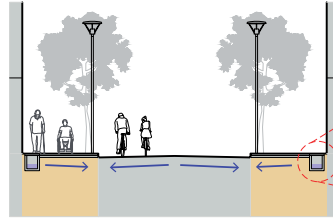
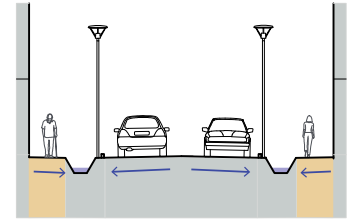
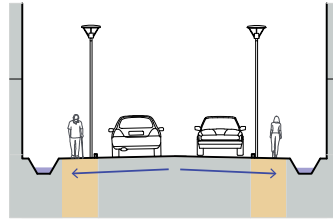

Figure 72. Footpaths should be raised above the level of the carriageway to prevent waterlogging. The drain should be placed on the outer edge of the footpath in order to make space for a tree line between the footpath and carriageway. Drain covers increase the footpath width.

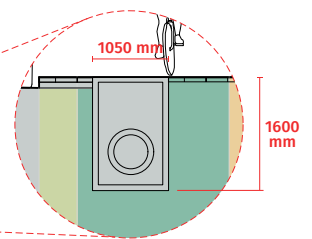
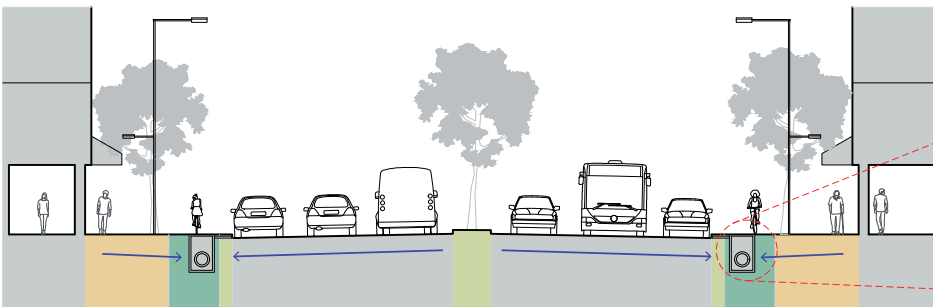
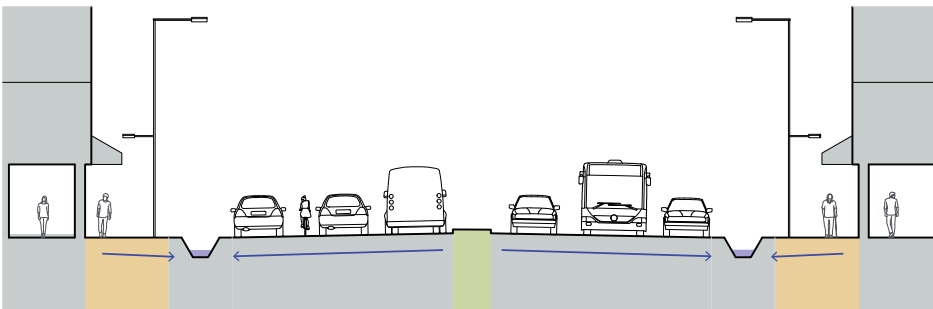

Figure 71. On collector and arterial streets, storm water should be carried underground to free up space for cycle tracks, wider footpaths, trees, and street furniture.

4.17. UTILITIES

Streets are the conduits for major services, including electricity, water, sewage, communication, and gas. The physical infrastructure may occur in the form of water and sewer pipelines, telephone and fibre optic cables, ducts, and poles. Some utilities, such as telecommunications cables, require frequent access for expansion and maintenance. The placement of above- and below-ground utilities at the appropriate location in the right-of-way ensures unconstrained movement as well as easy access for maintenance.

DESIGN CRITERIA

- ▶ Underground utilities are ideally placed below the parking area or service lane, if present, which can be dug up easily without causing major inconvenience. Where this is not possible, utilities can be placed at the outer edge of the street or under the footpath.
- ▶ Utility boxes should be sited in the furniture zone or in easements just off the right-of-way to reduce conflicts with pedestrian movement. If it is absolutely necessary to locate utility access points in the footpath, a clear width of at least 2 m should be maintained for pedestrian movement. Similarly, utility boxes should never constrain the clear width of a cycle track.
- ▶ Though it is possible to accommodate underground utilities even below a tree line, this may lead to the destruction of the trees and a deterioration in liveability if the utilities need to be uncovered.
- ▶ In order to minimise disruptions, telecommunication lines should be placed in ducts that can be accessed at frequent service points.
- ▶ Position utilities as follows:
 - Major water pipes (e.g., 200 mm): 0.9-1.5 m below the surface.
 - Water distribution pipes: 0.4-0.6 m below the surface.
 - Sewer: Greater depth than nearby water lines.
 - Telecom: 0.3-0.6 m below the surface in service ducts.
 - Electricity: For underground cables, depth below the surface per Table 7 and minimal clearance of 200 mm from other lines. Electrical cables crossing the street should be protected with 150 mm surround. For overhead cables, clearance per Table 8.

Table 7. Depth of underground electrical cables.

Voltage (kV)	Depth (m)
Low voltage	0.6
11	0.9-1.0
33	1.2
66	1.5
132	1.8
220	2.1

Table 8. Clearance for overhead electrical cables.

Voltage (kV)	Height (m)	Clearance from buildings (m)	
Low voltage	4.5	2.0	
11	5.5	2.7	
33	6.1	2.9	
66	6.1	3.6	
132	6.8	15.0	
220	6.8	20.0	

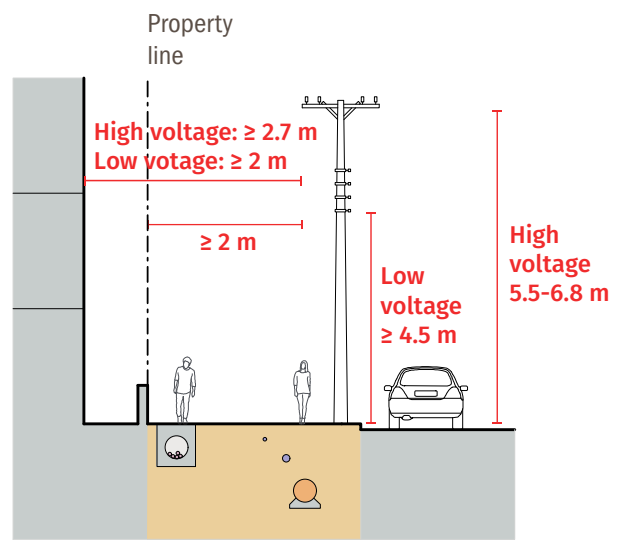
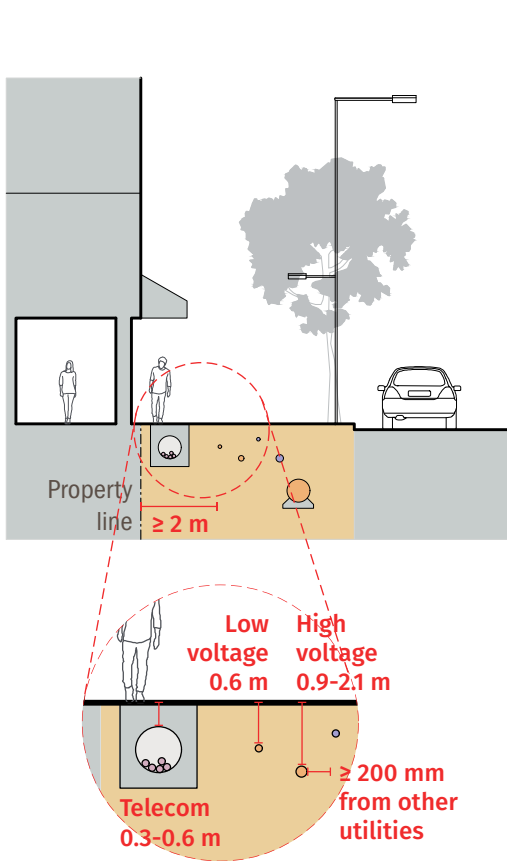

Figure 74. Guidelines for placement of telecom cables and underground (left) and overhead (right) electricity lines.

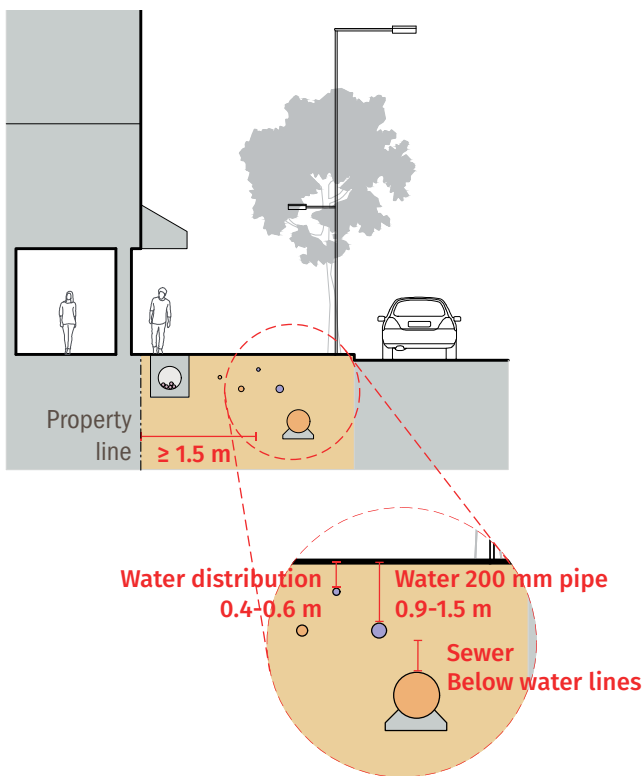

Figure 75. Guidelines for placement of water and sewer lines.

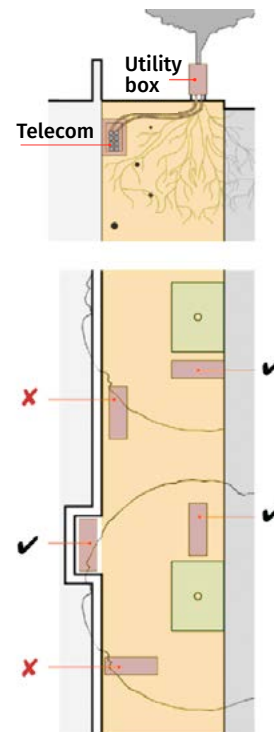

Figure 76. Proper placement of utilities can help ensure that pedestrian movement can occur unimpeded.



5. STREET TEMPLATES

This section provides a collection of street templates to show how the elements presented above can be combined to provide varying degrees of liveability and mobility. Each template contains a ground plan and section at a scale of 1:200.

The templates are then shown in order of increasing street width: 2, 4, 6, 9, 12, 15, 18, 25, 30, 34, 40, 50, and 60 m. Each template can be adjusted for a slightly wider right-of-way by increasing the width of any element except the carriageway and parking lanes.

Table 9. Guide to the templates.

Street type	Shared space	Footpath	Cycle track	Dual carriageway	BRT
2	●				
4	●				
6	●				
9	●				
12a		●			
12b		●			
15a		●	●		
15b		●			
18a		●	●		
18b		●	●		
18c		●			
18d		●			●
25a		●	●		
25b		●			●
30a		●	●	●	
30b		●		●	●
34a		●		●	●
40a		●		●	
40b		●		●	
40c		●	●	●	●
50a		●	●	●	
50b		●	●	●	●
60a		●	●	●	●

2 m Option A



Shared space

2 m

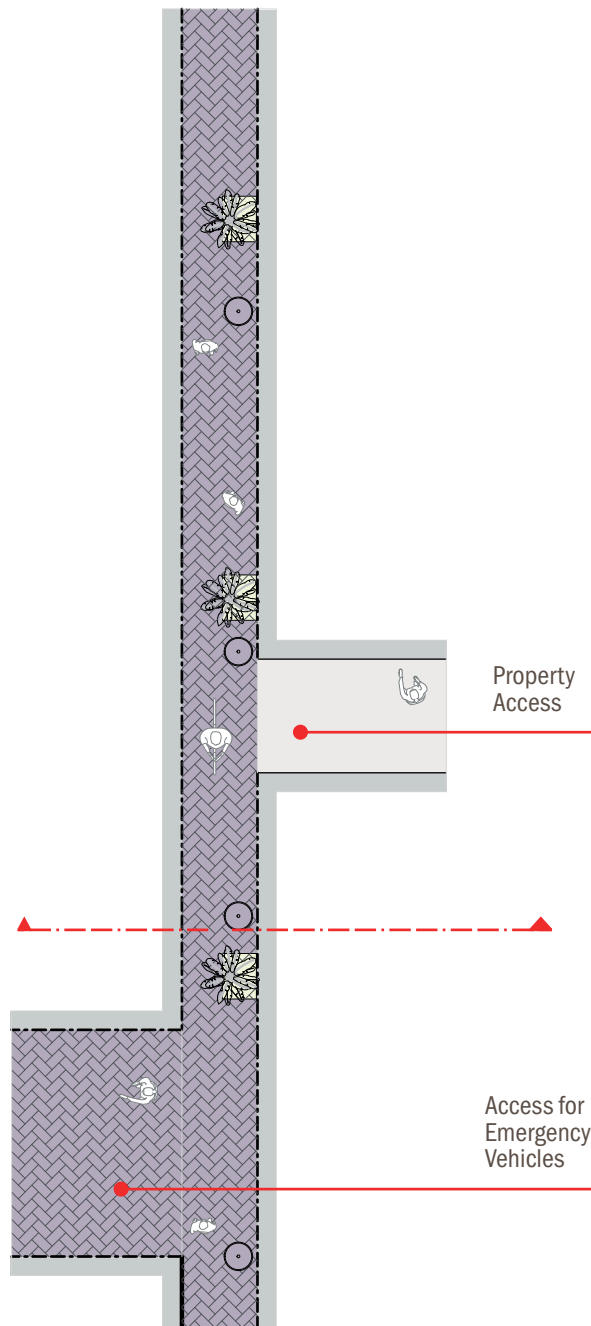

Property Access

Access for
Emergency
Vehicles

4 m Option A

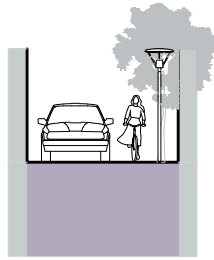

Shared space

4 m

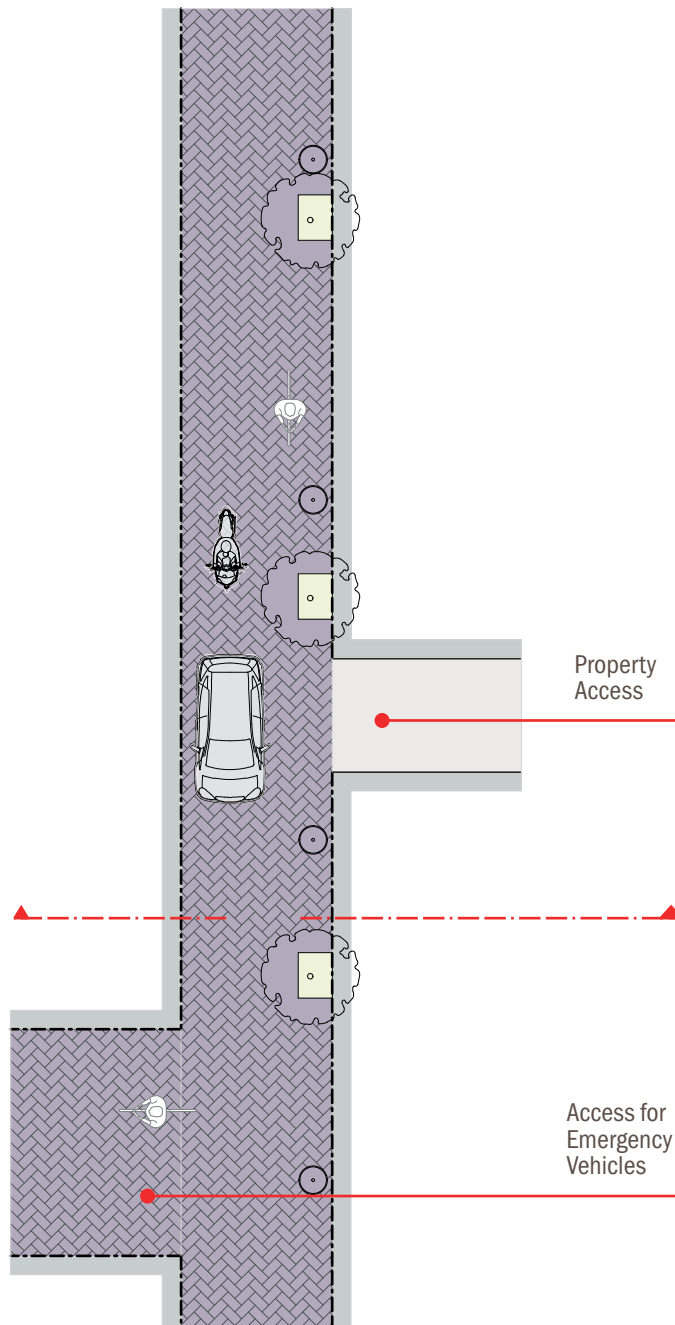

Property Access

Access for
Emergency
Vehicles

6 m Option A



Shared
space

6 m

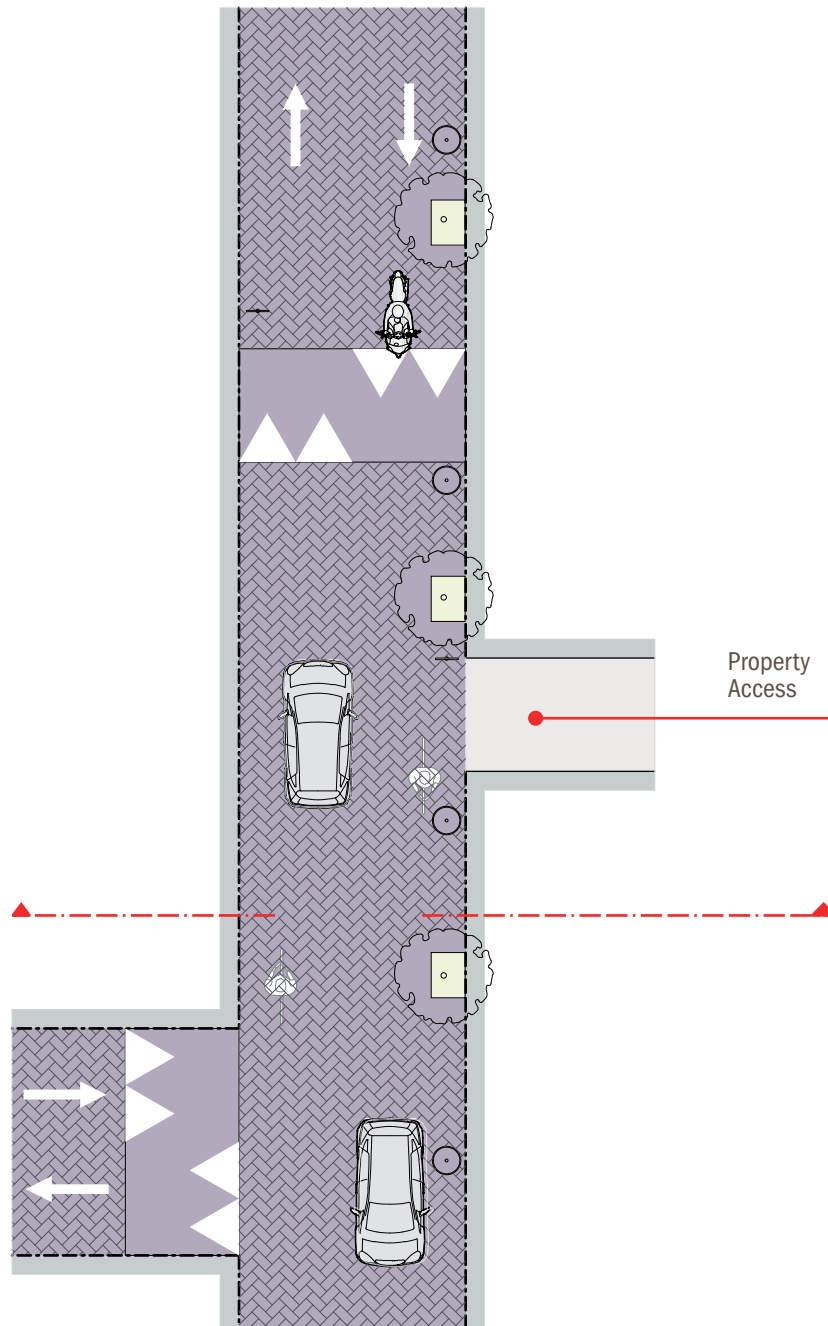

9 m Option A

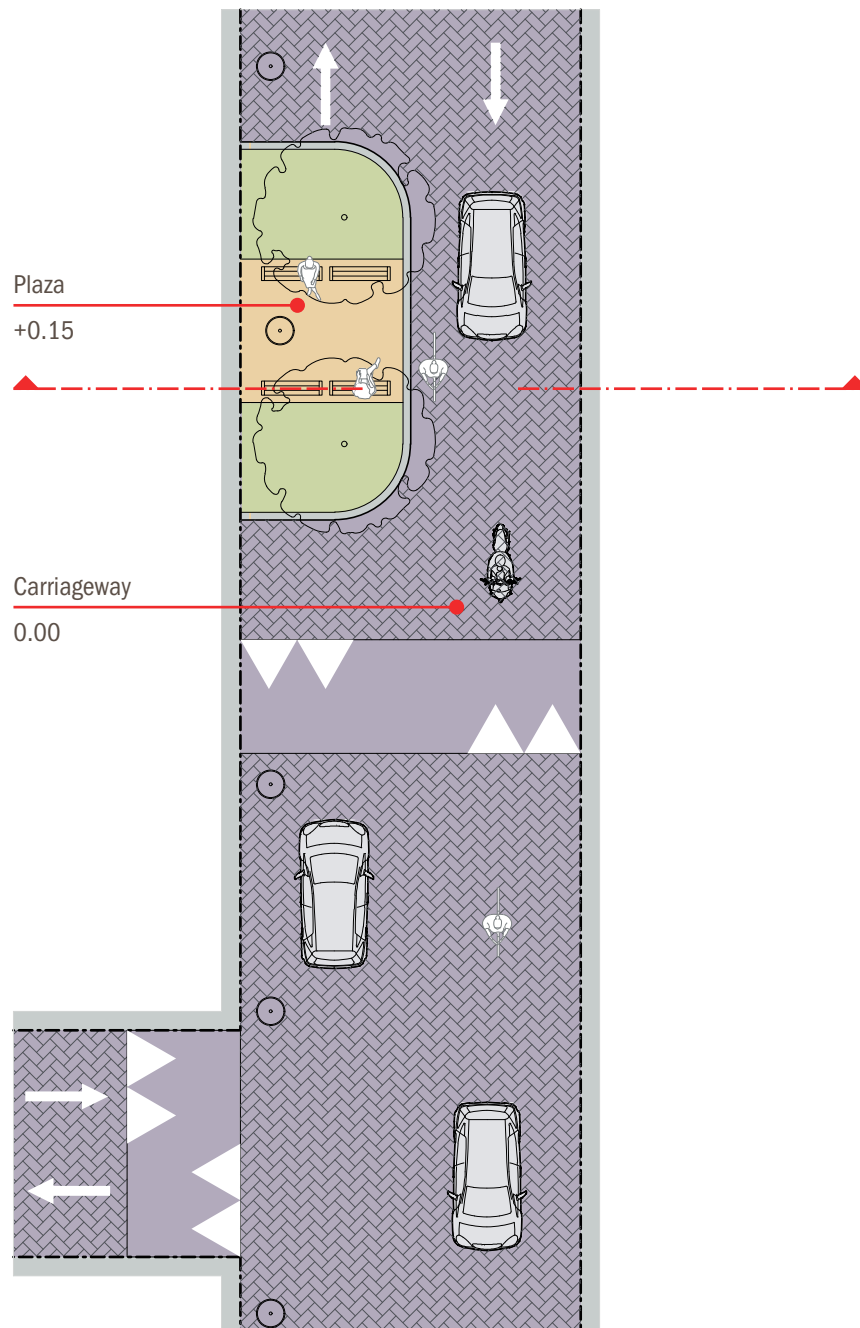
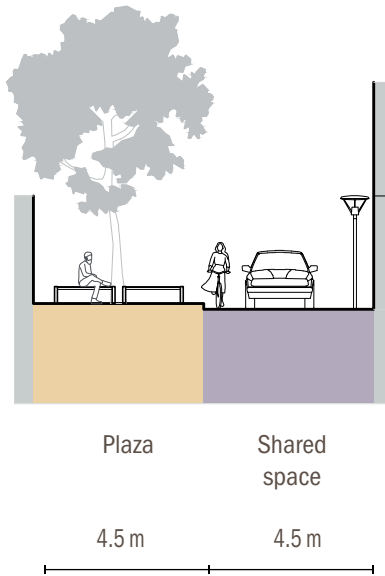

12 m

Option A

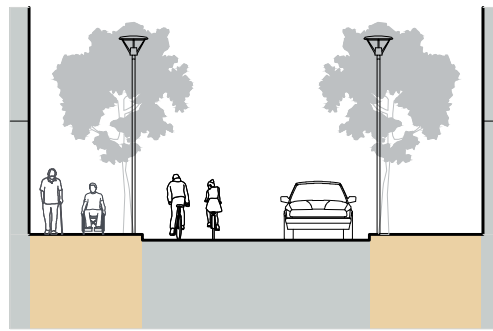

Footpath Carriageway Footpath

3 m 6 m 3 m

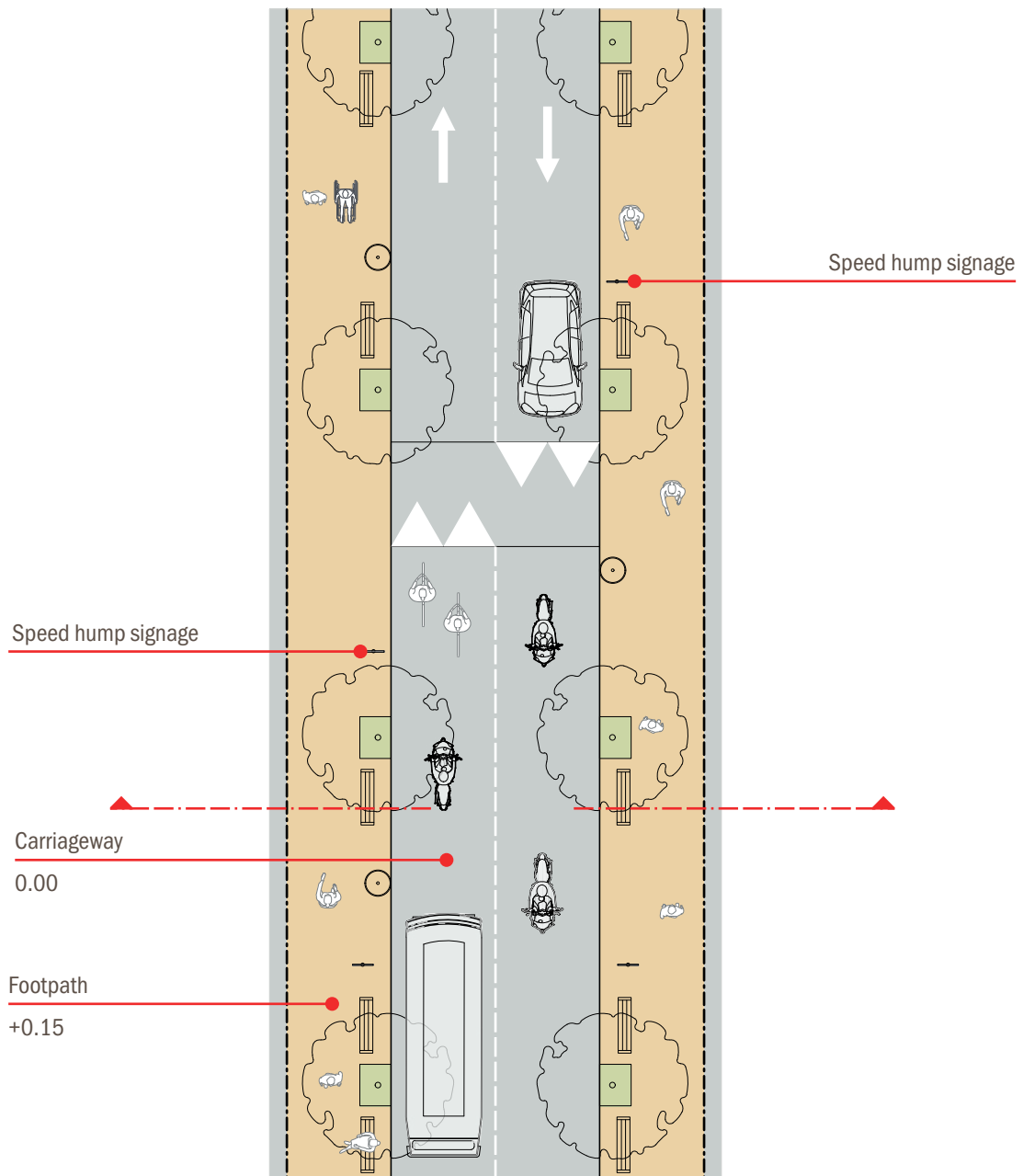

Speed hump signage

Speed hump signage

Carriageway

0.00

Footpath

+0.15

12 m Option B

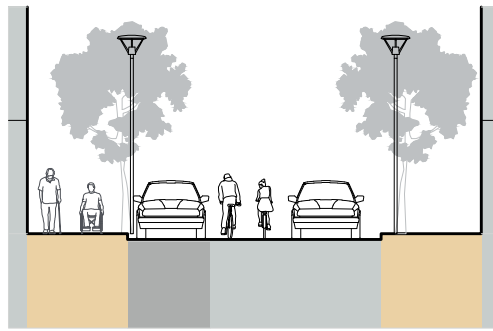

Footpath Parking Carriageway Footpath

2.65 m 2.2 m 4.5 m 2.65 m

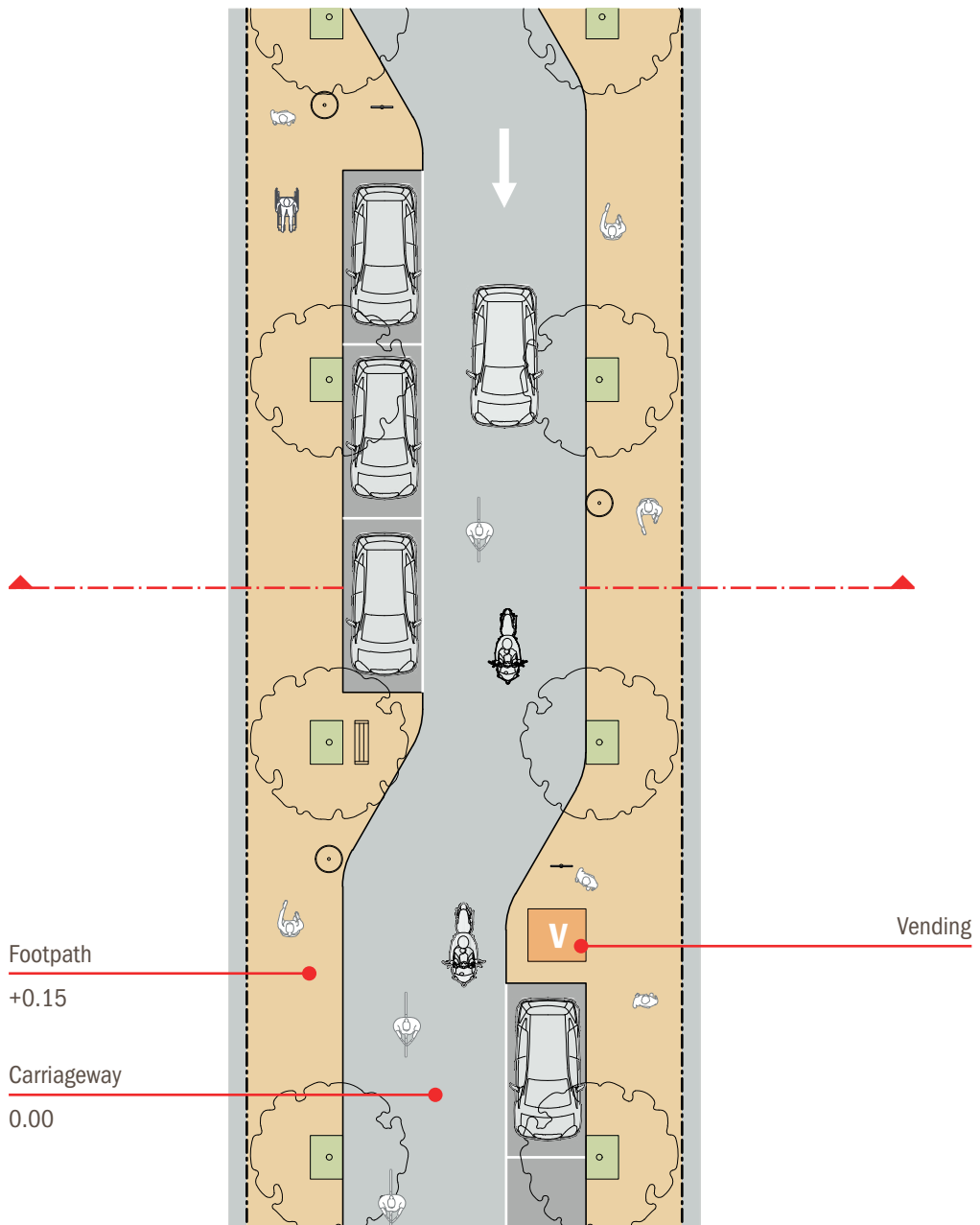

Footpath

+0.15

Carriageway

0.00

Vending

15 m

Option A

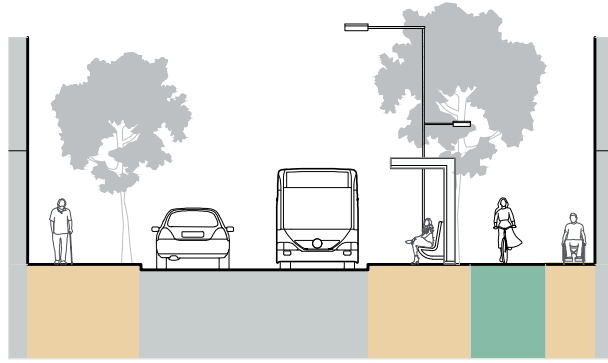

Footpath	Carriageway	Bus stop	Cycle track	Footpath
3 m	6 m	2.2 m	2 m	1.8 m

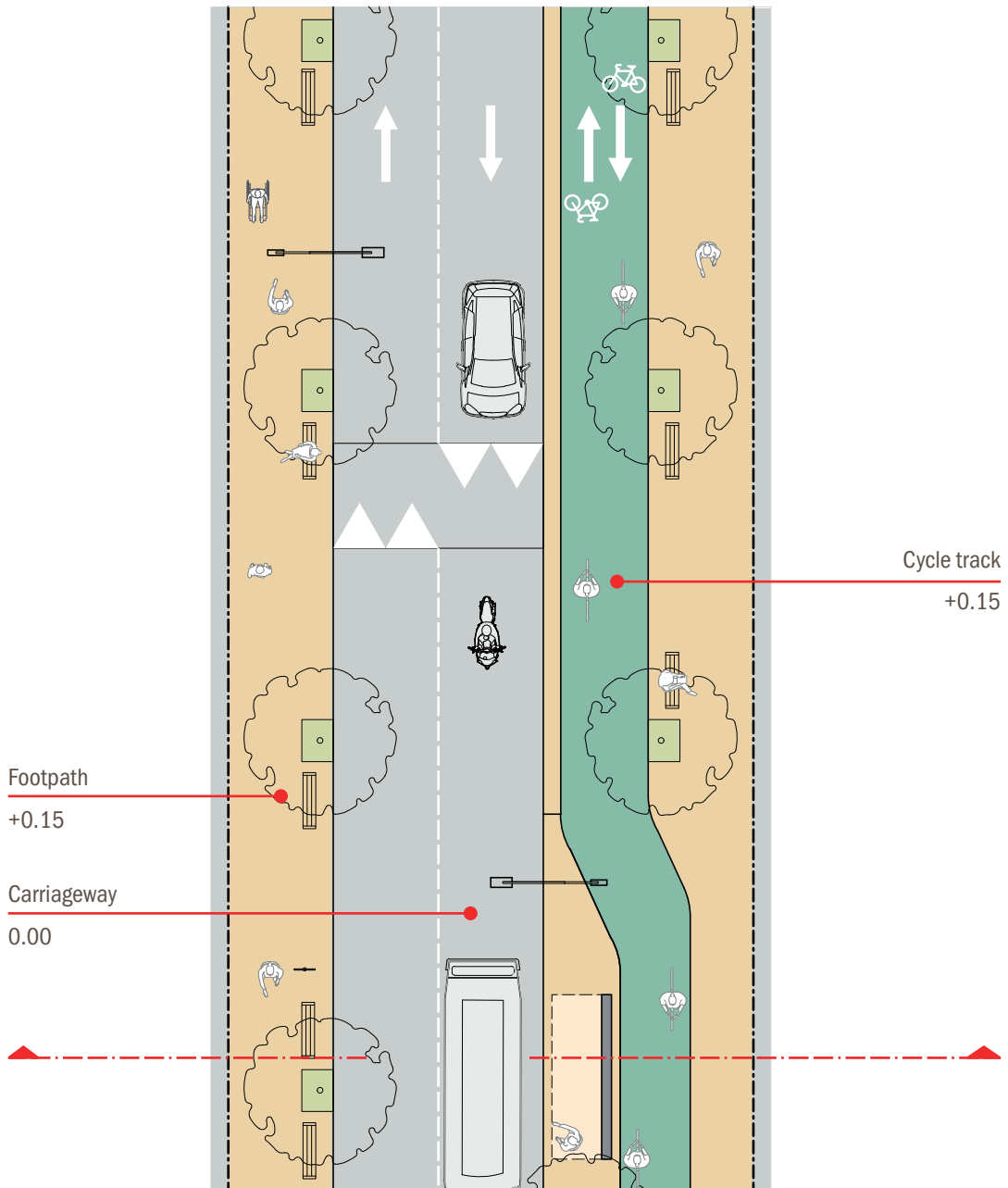

15 m Option B

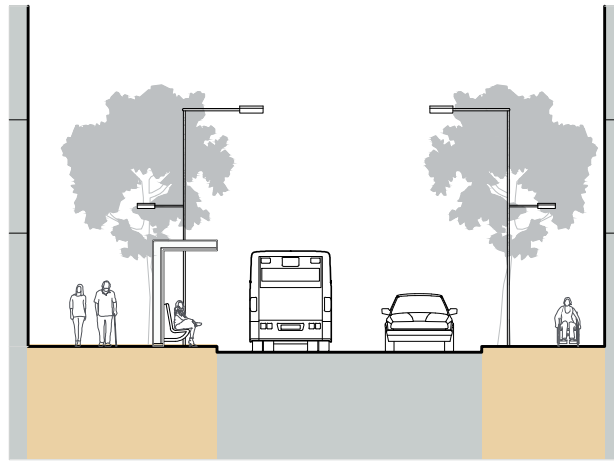

Footpath	Bus stop	Carriageway	Footpath
3.3 m	2.2 m	6.5 m	3 m

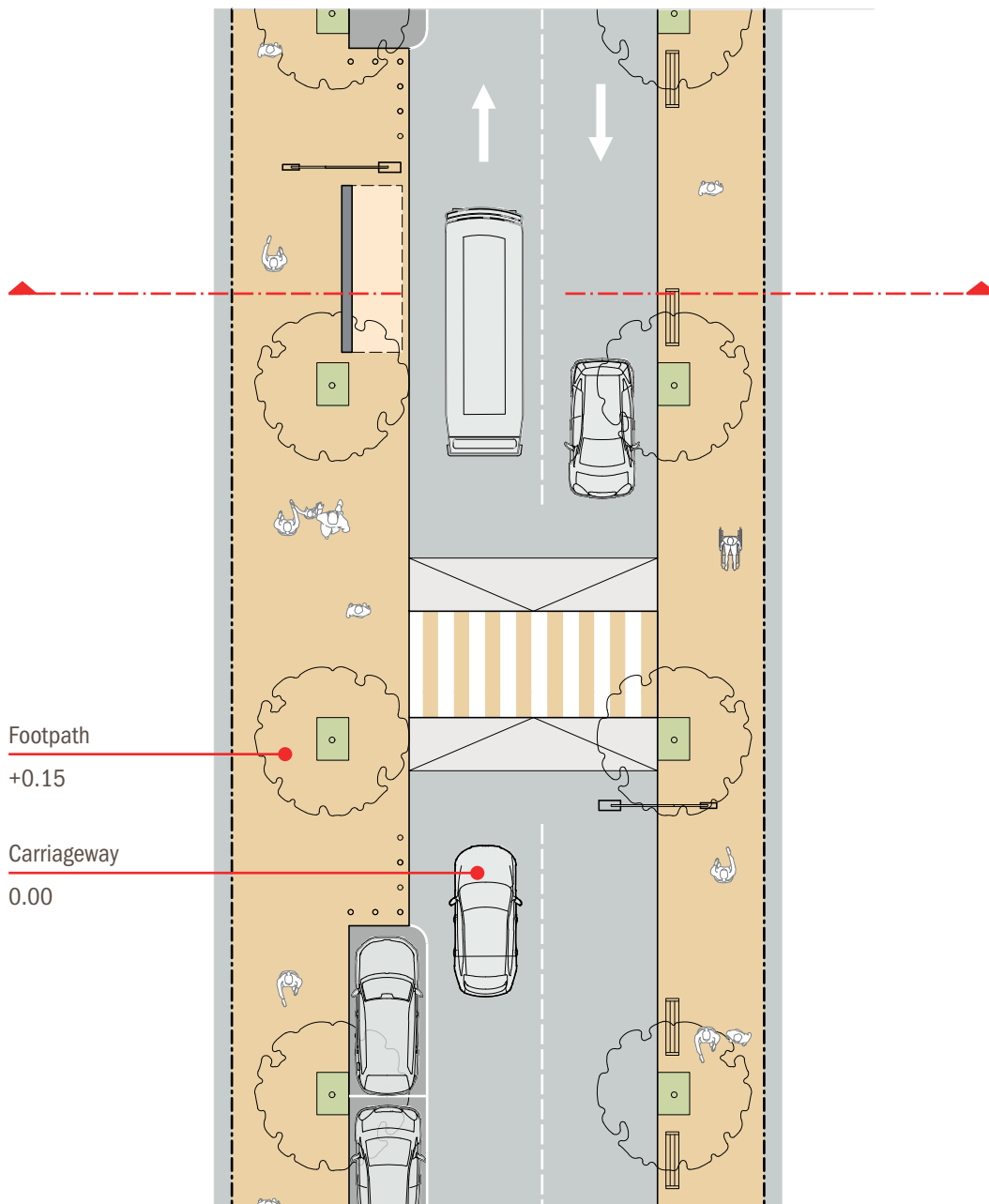

18 m

Option A



Footpath	Cycle track	Carriageway	Bus stop	Cycle track	Footpath
3.25 m	2 m	6.5 m	2.7 m	1.8 m	1.25 m

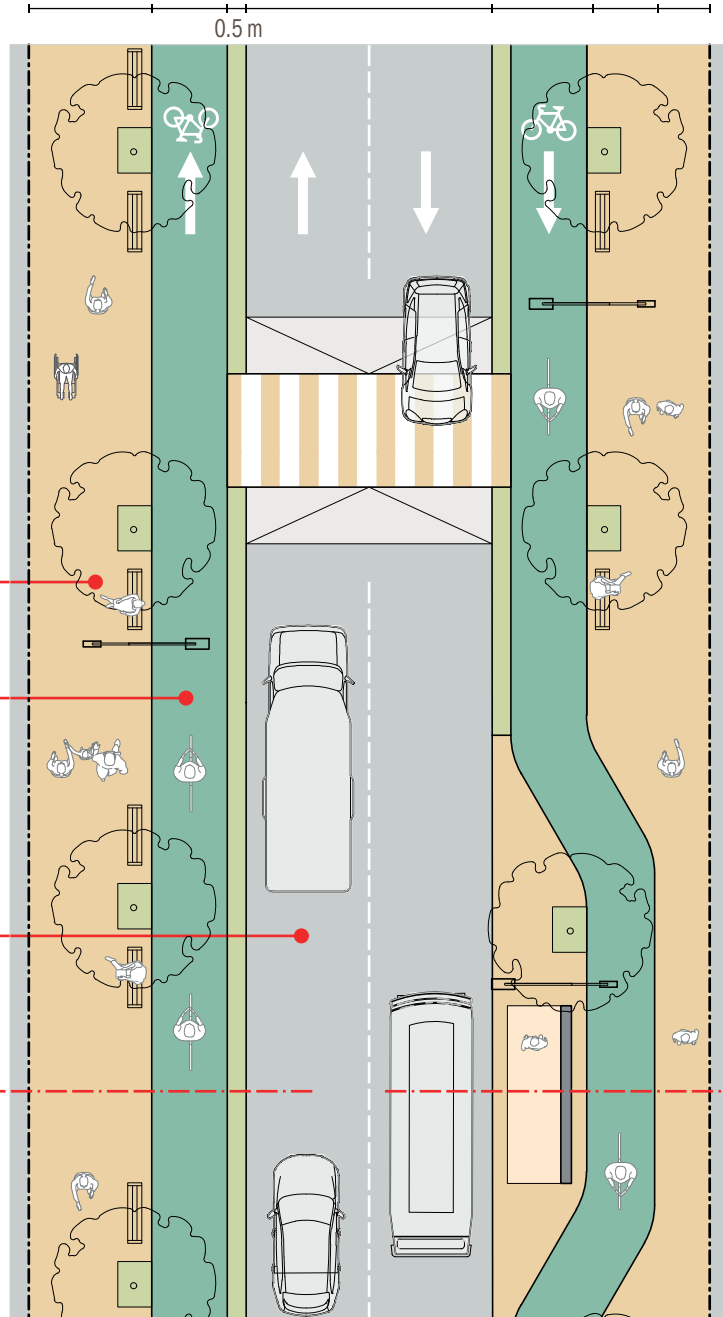

18 m Option B



Footpath	Cycle track	Bus stop	Carriageway	Cycle track	Footpath
1.95 m	2 m	2.2 m	6.5 m	2.2 m	3.15 m

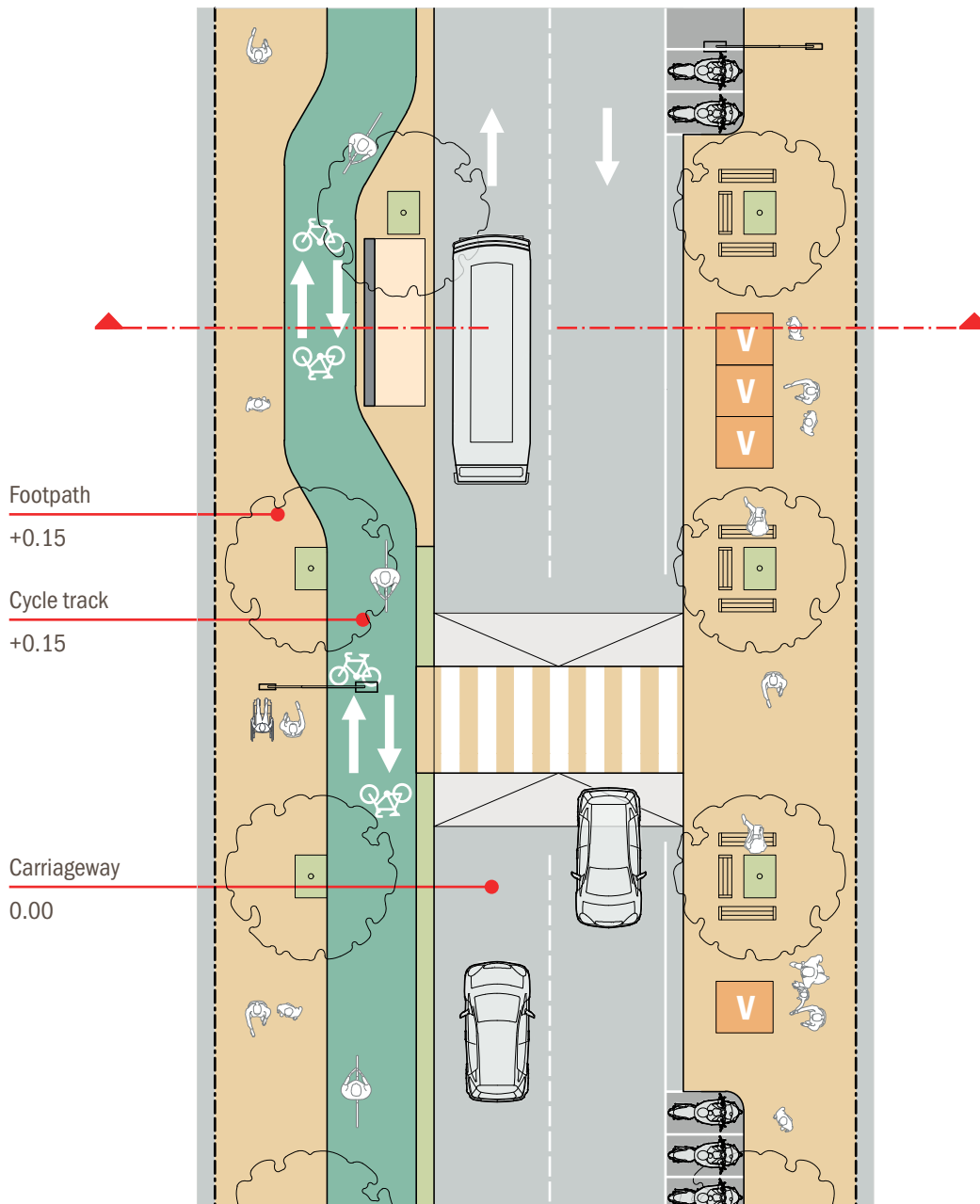

18 m

Option C

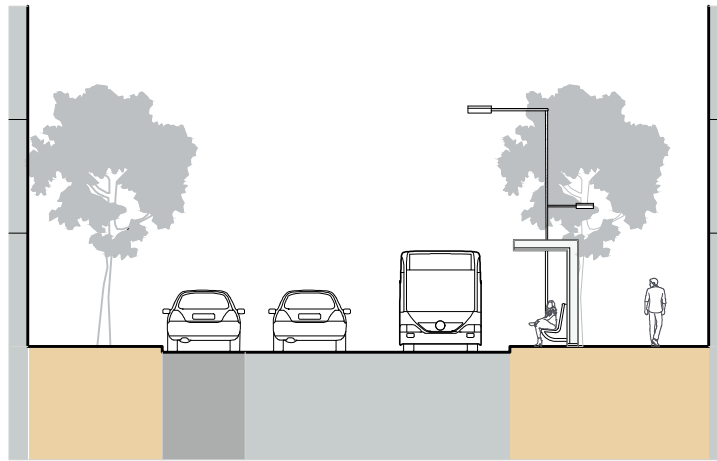

Footpath	Parking	Carriageway	Bus stop	Footpath
3.55 m	2.2 m	6.5 m	2.2 m	3.55 m

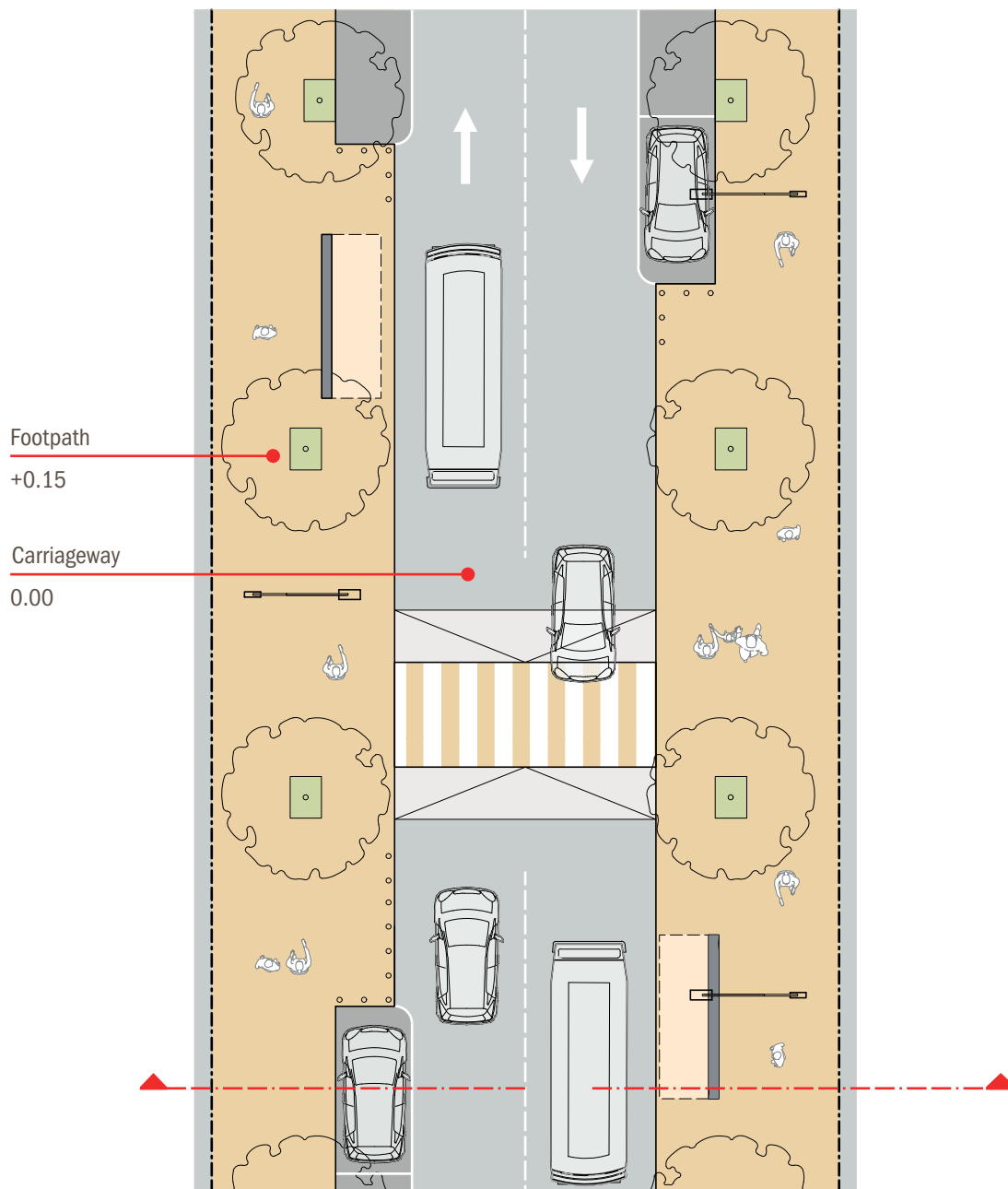

18 m

Option D

Off station

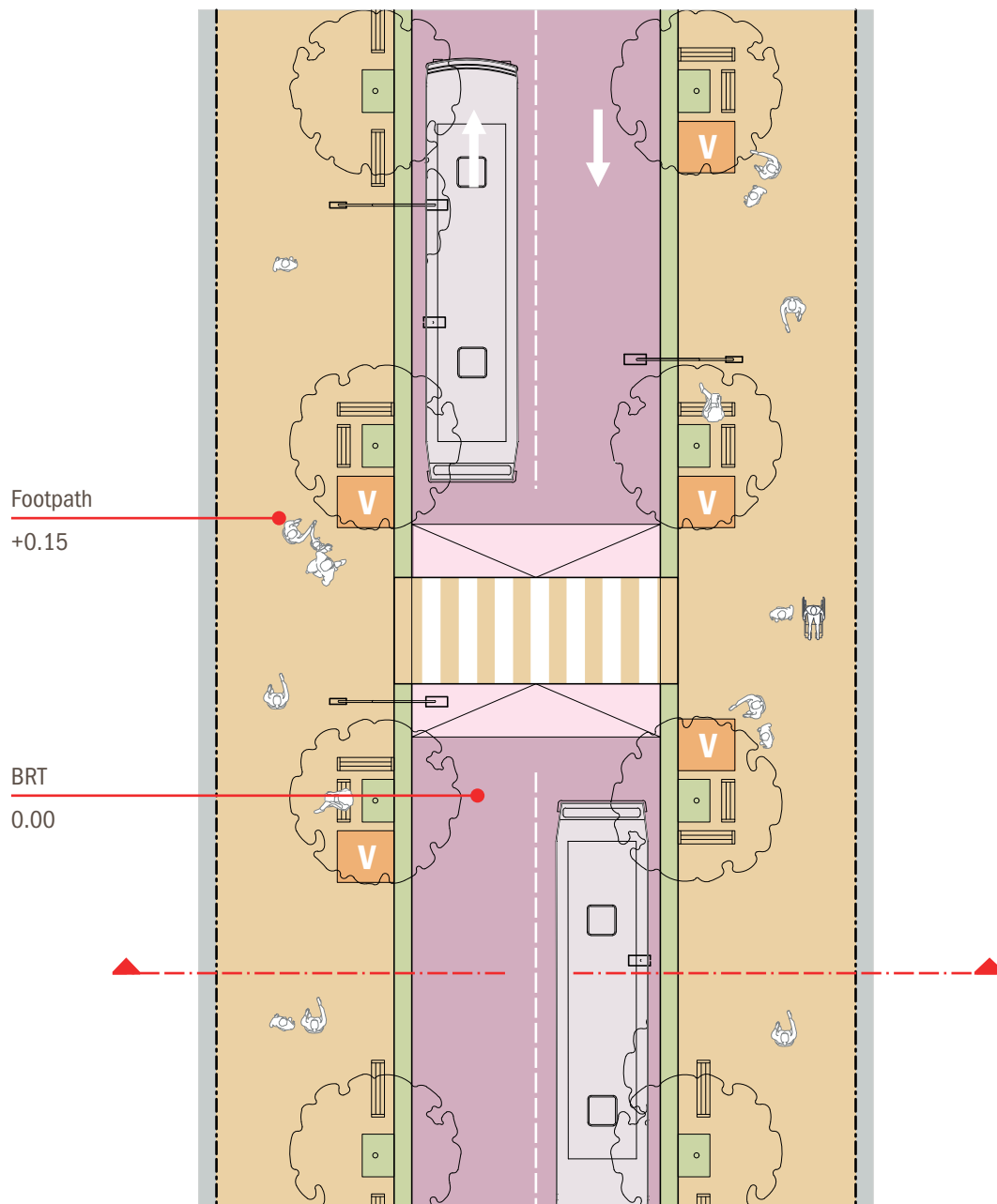
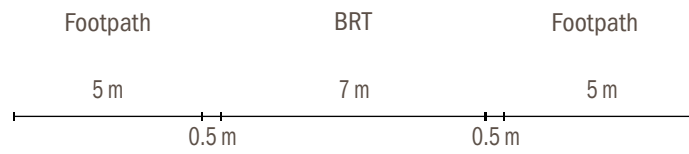
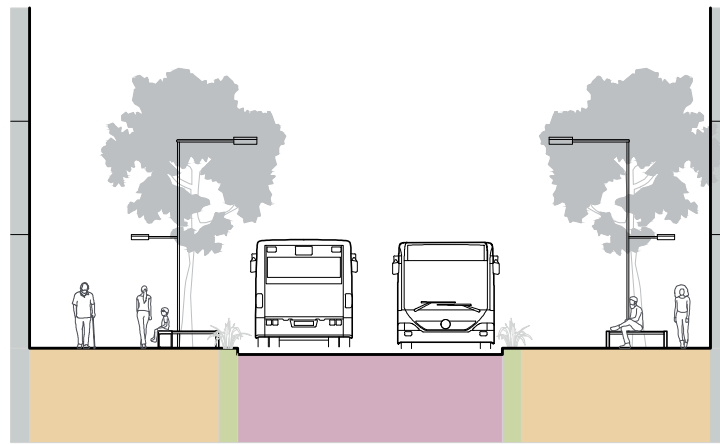

18 m

Option D

At station

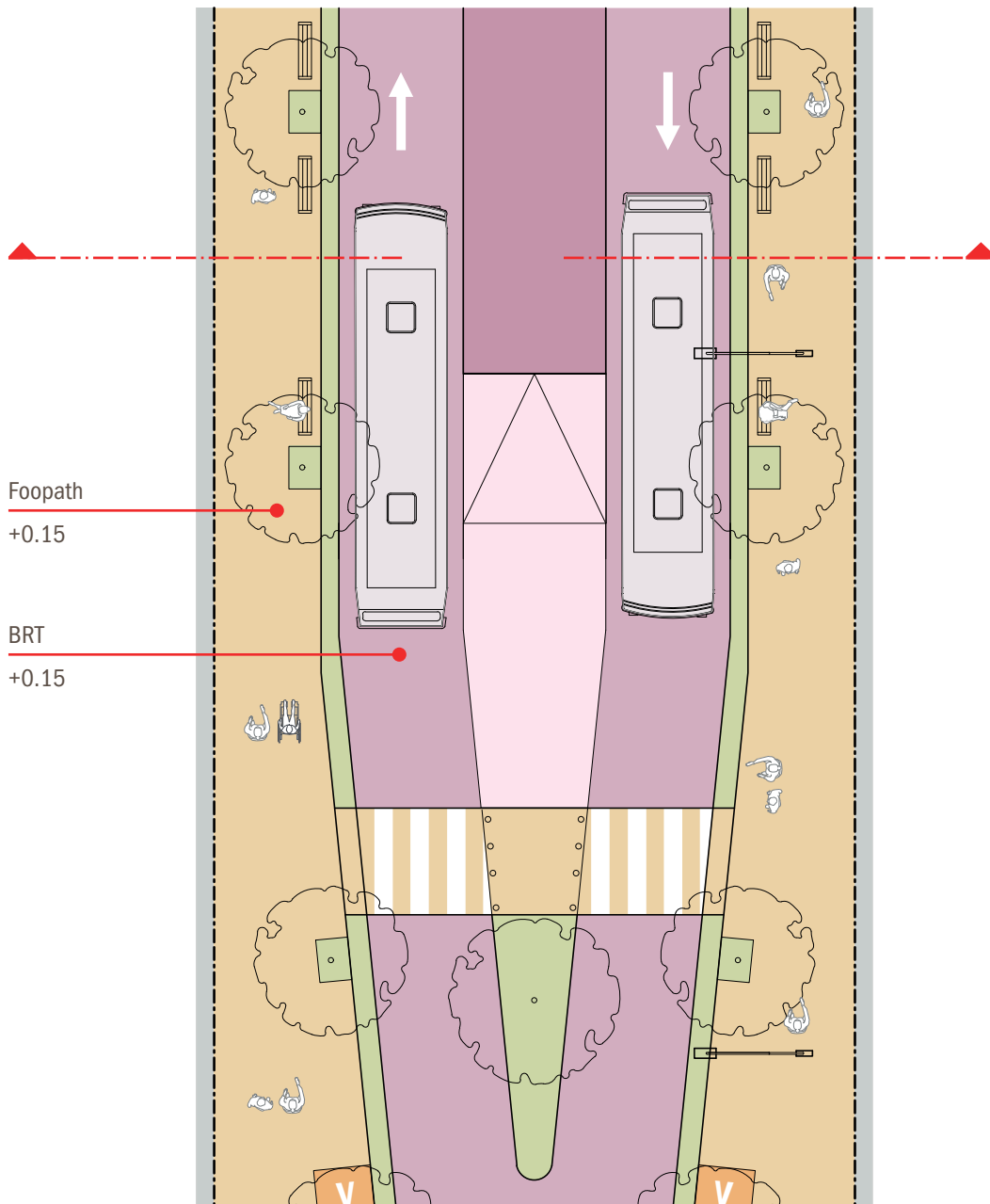
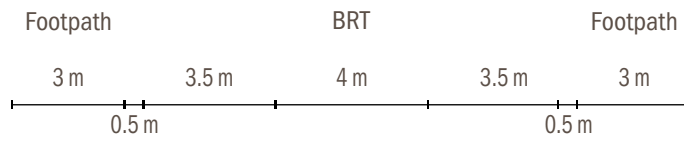
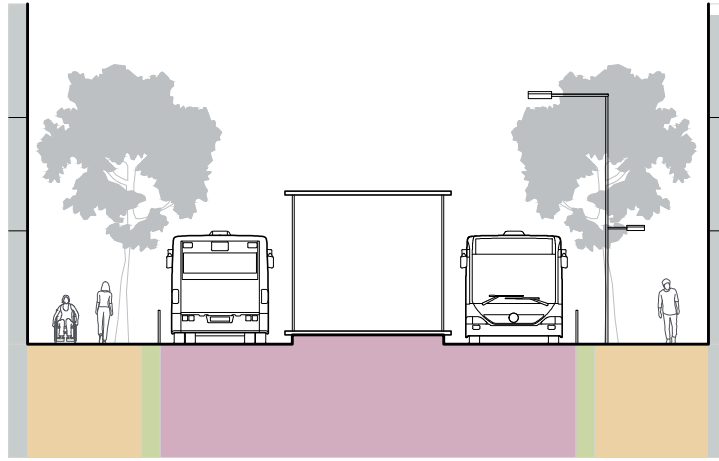

25 m Option A

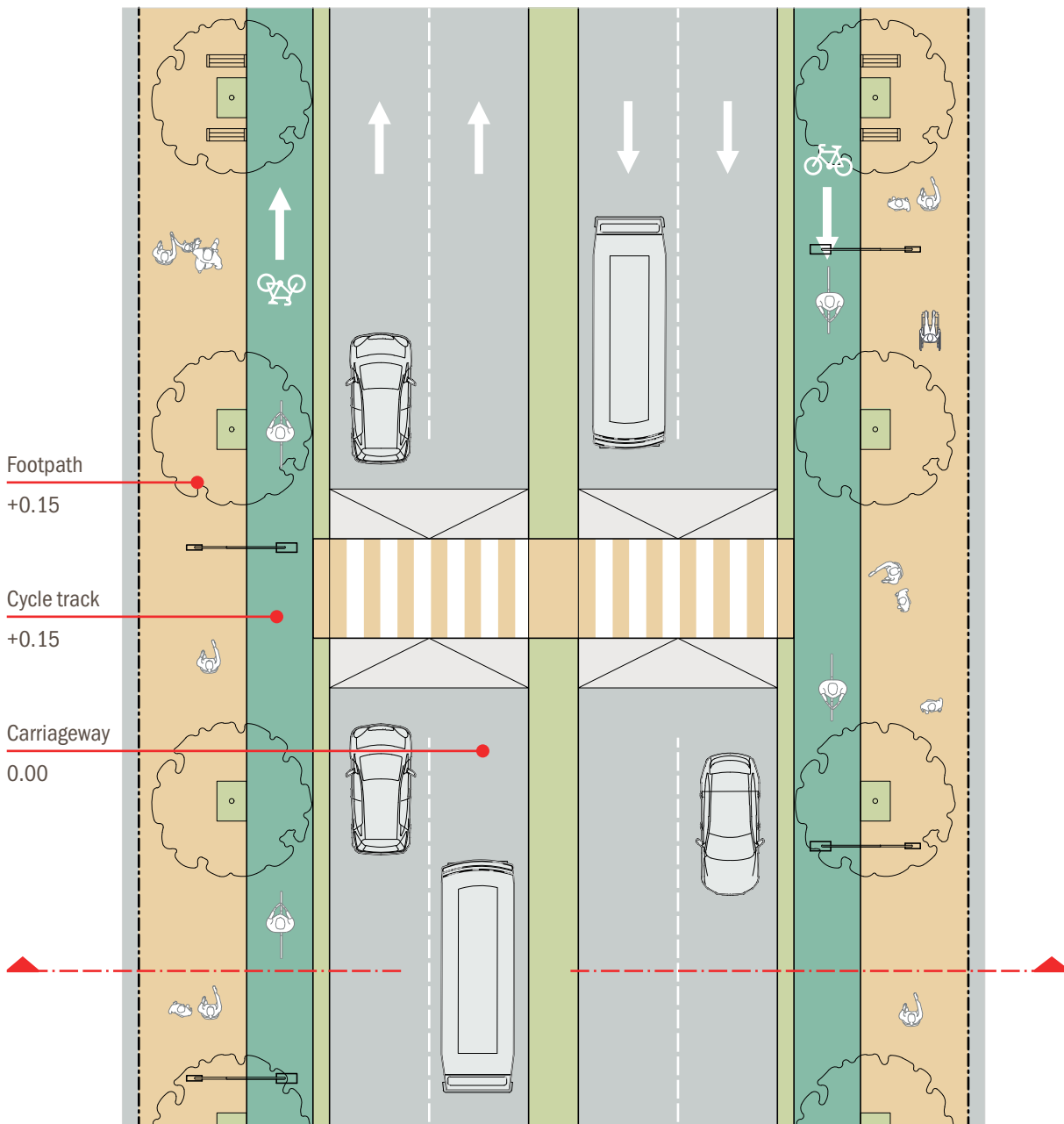
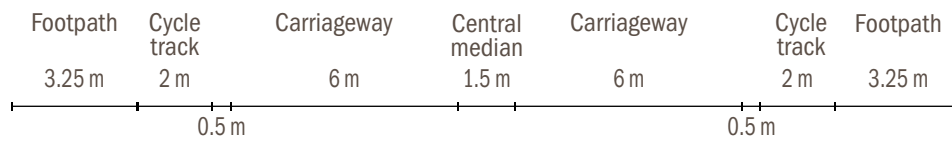
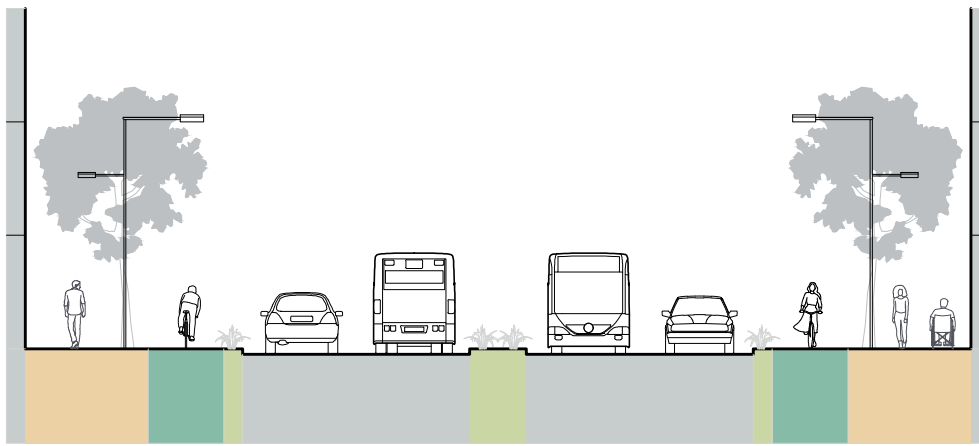

25 m

Option B

Off station

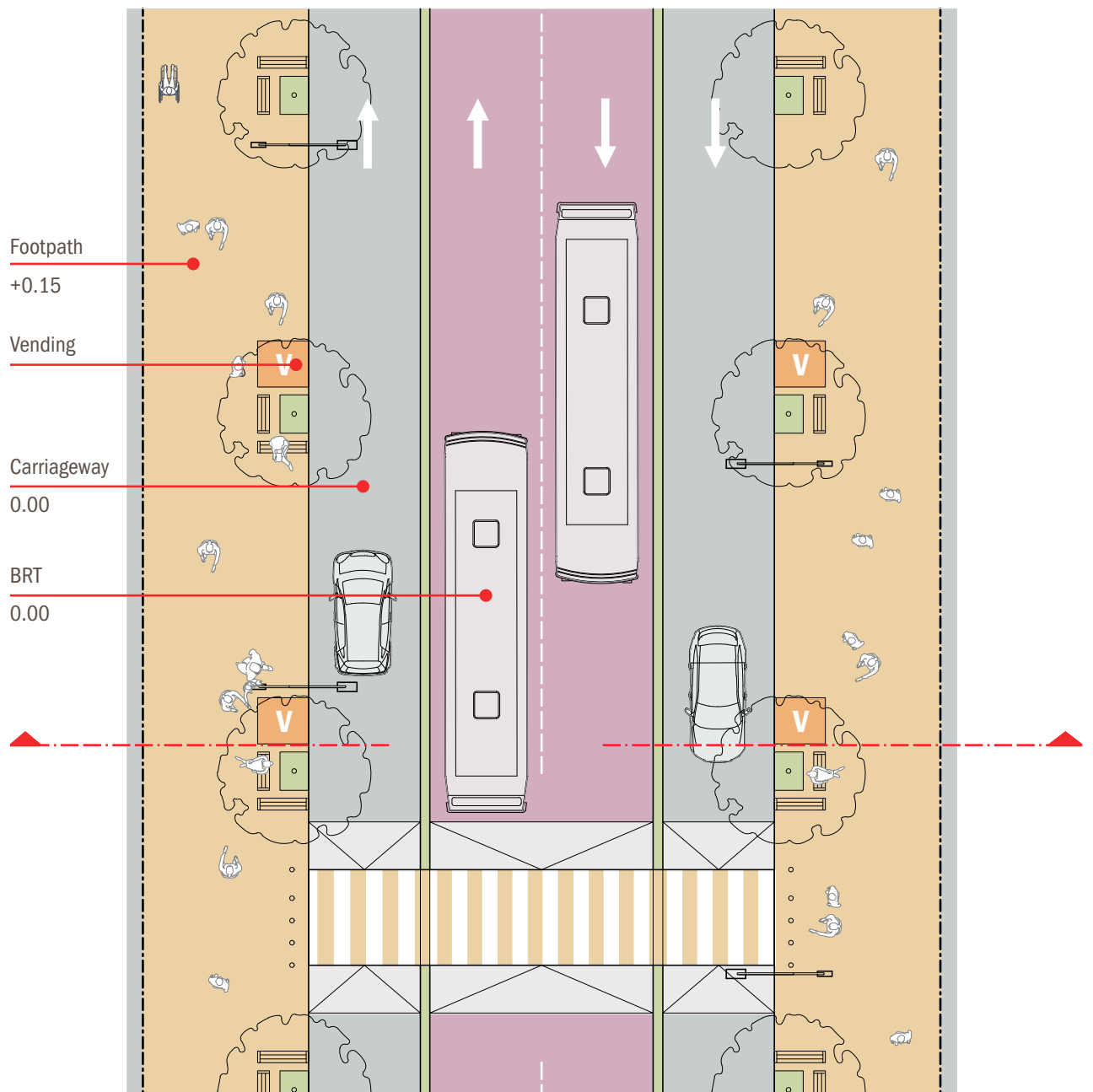
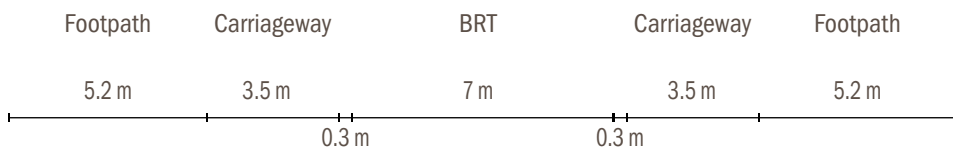
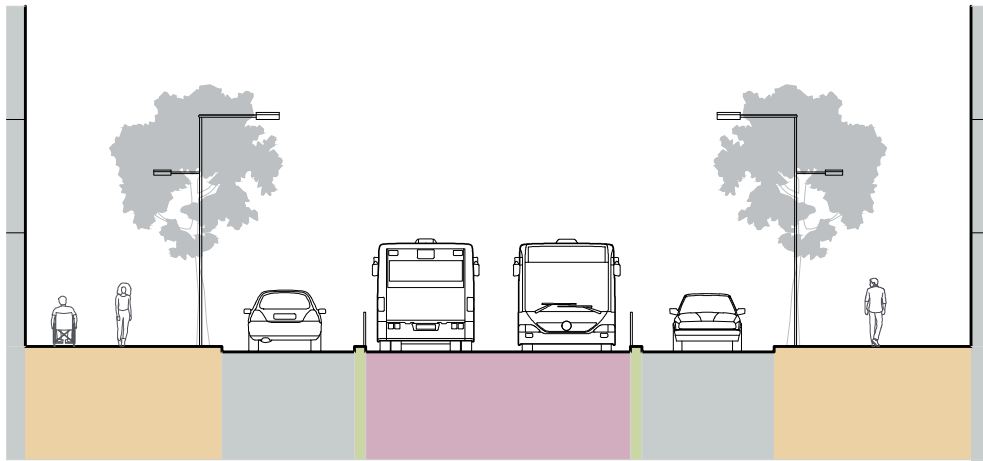

25 m

Option B

At station

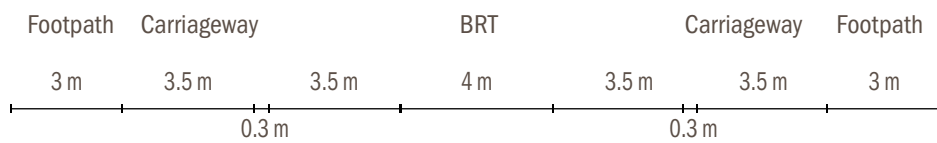
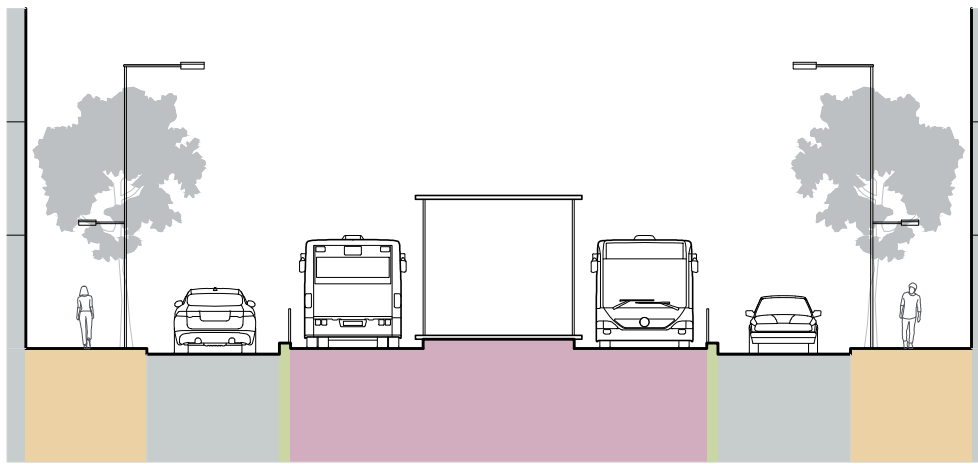

30 m Option A

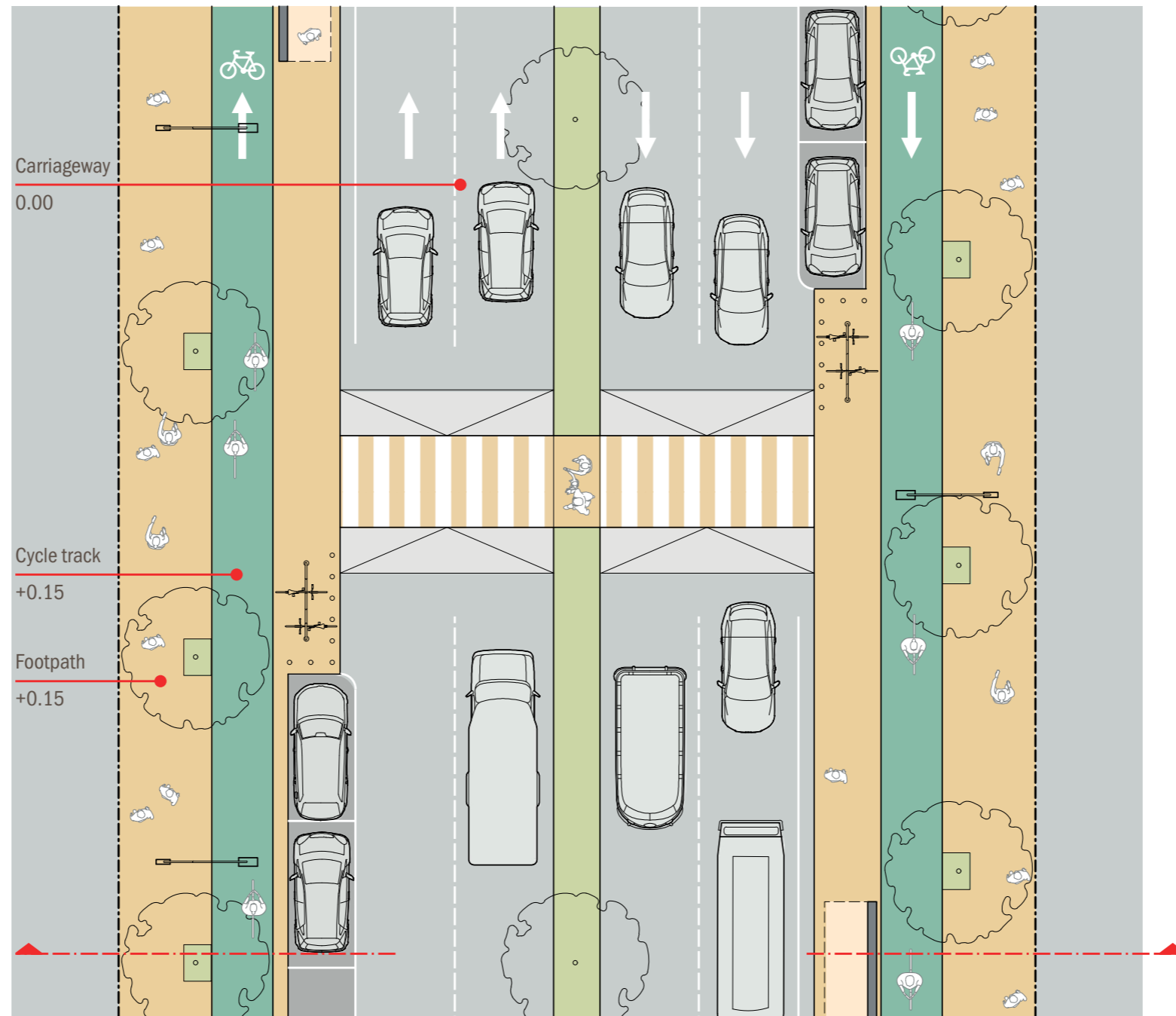
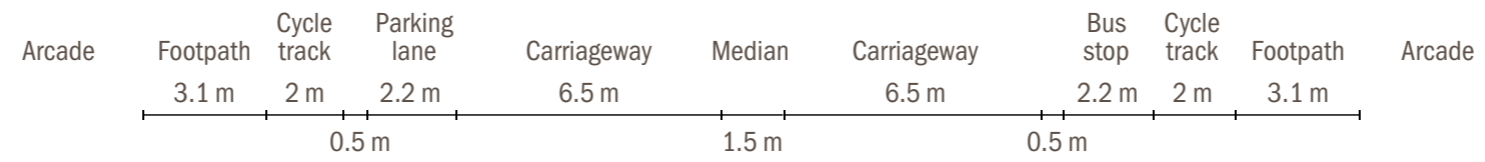
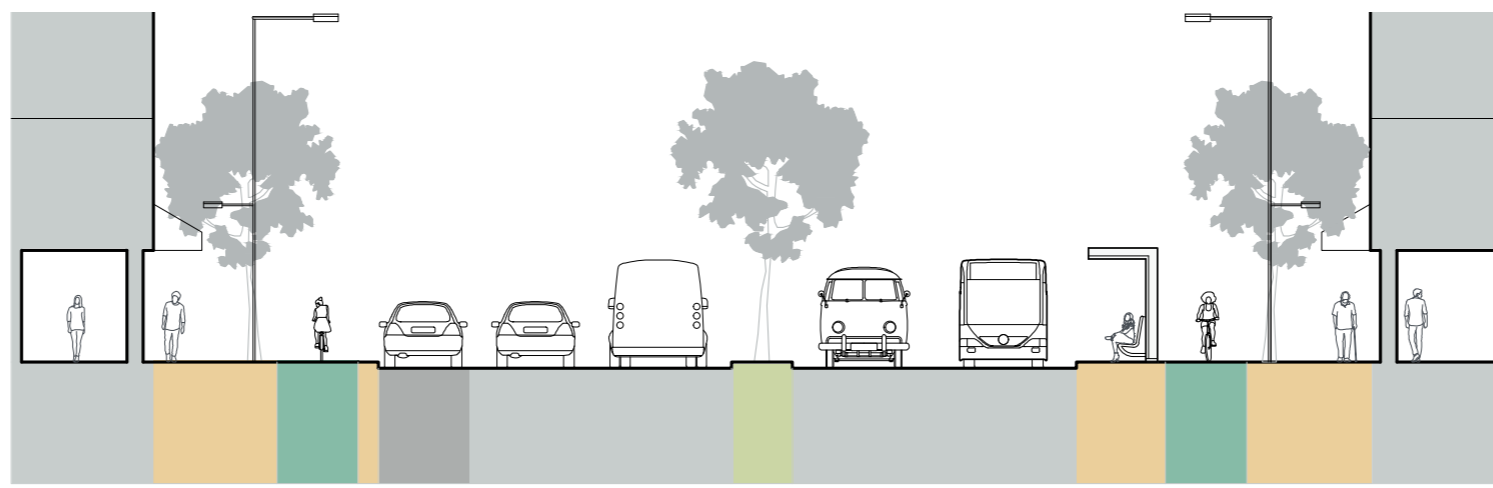

30 m
Option B
Off station

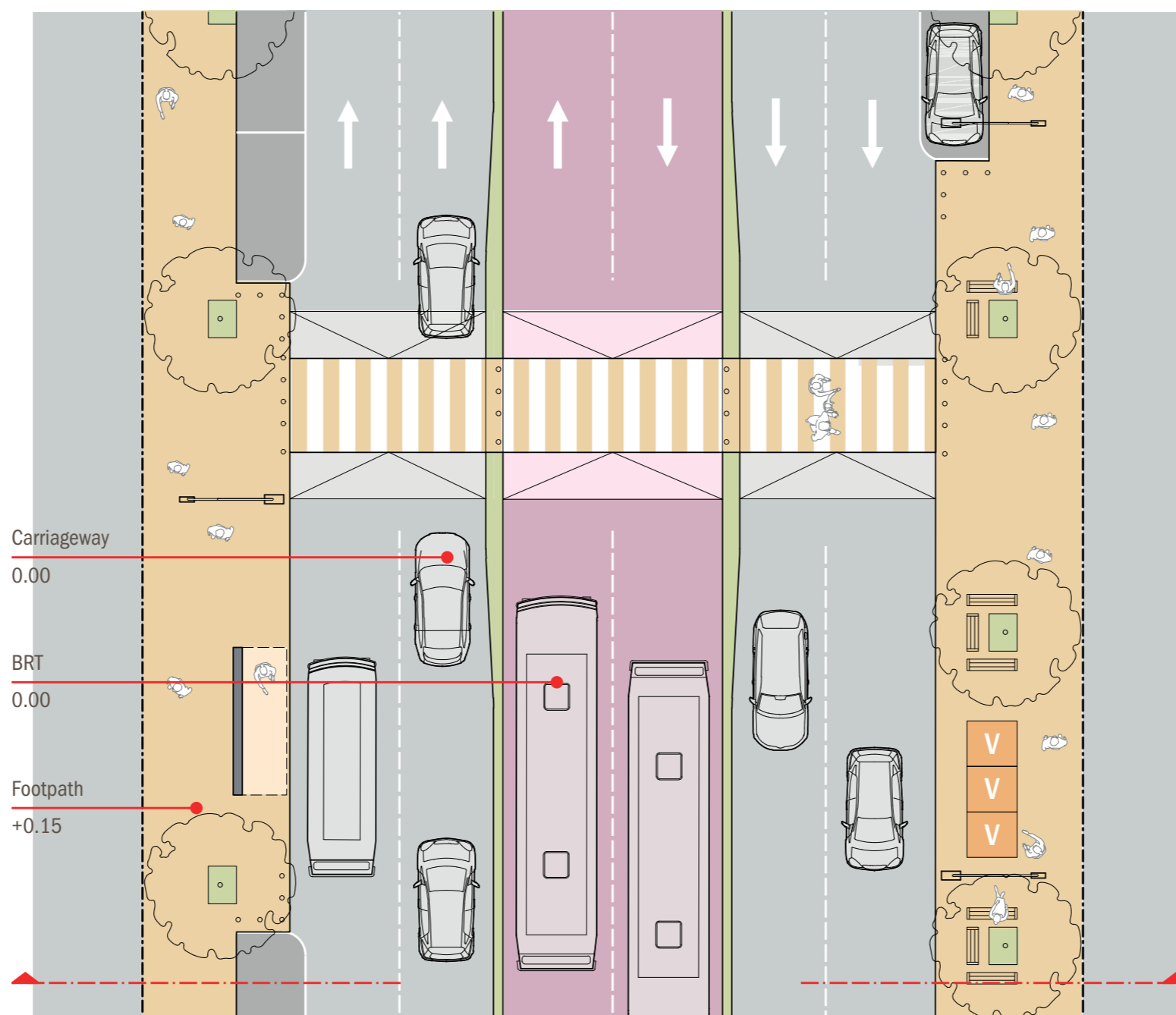
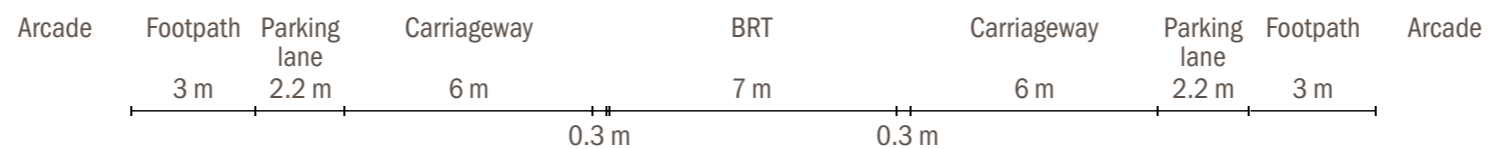
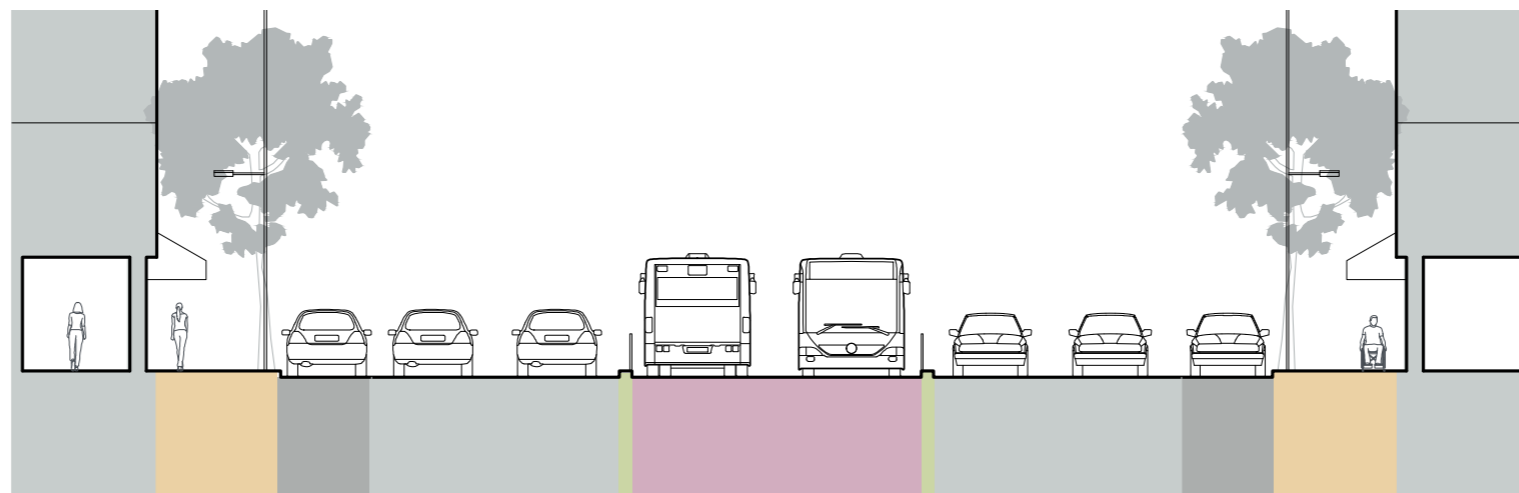

30 m
Option B
At station

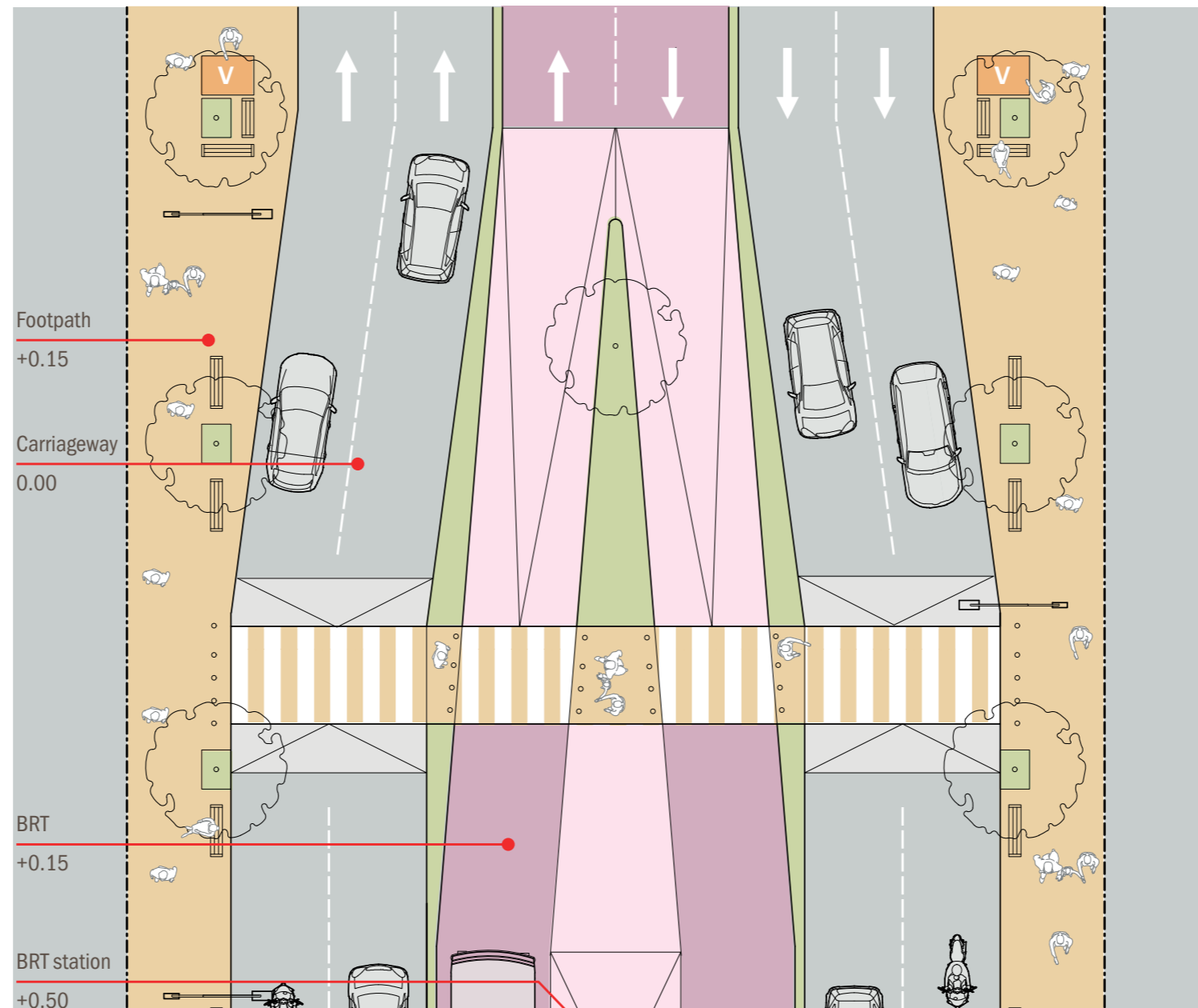
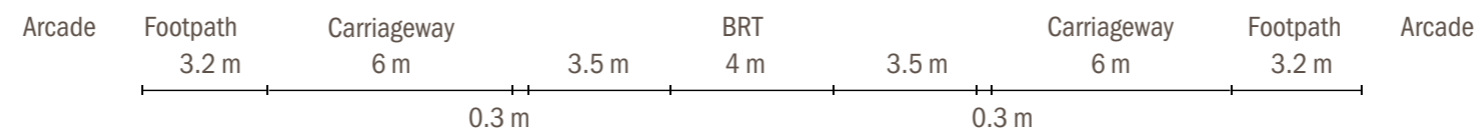
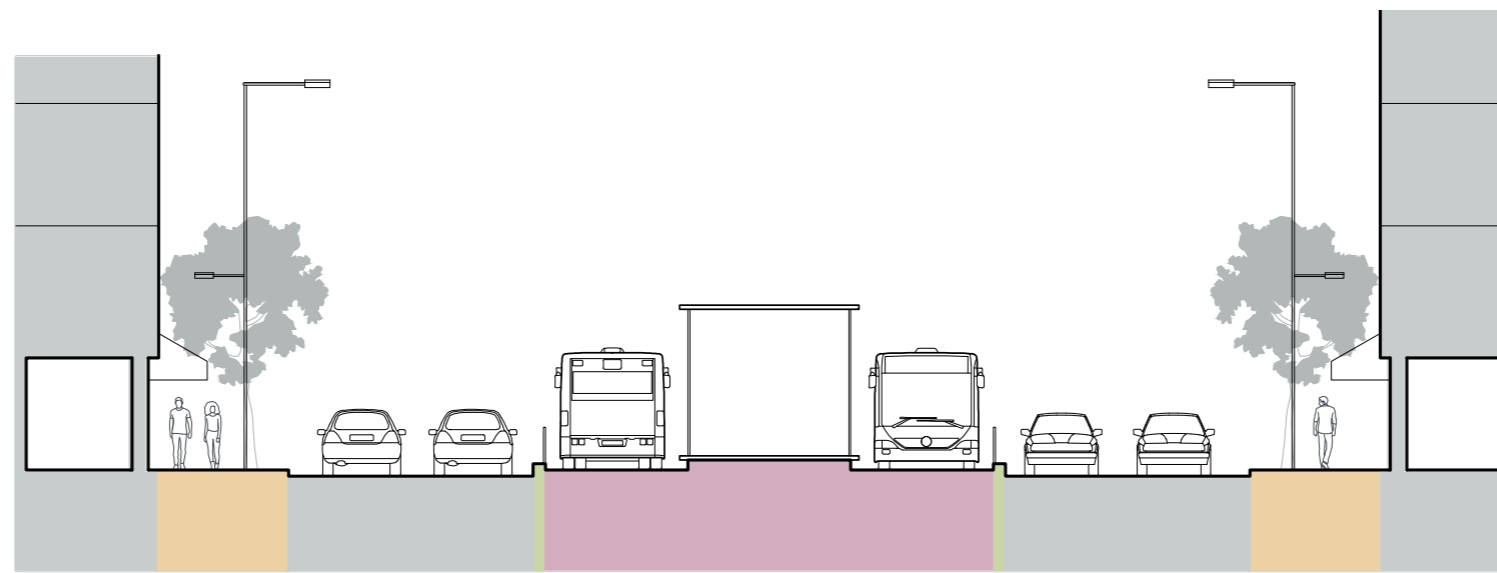

34 m
Option A
Off station

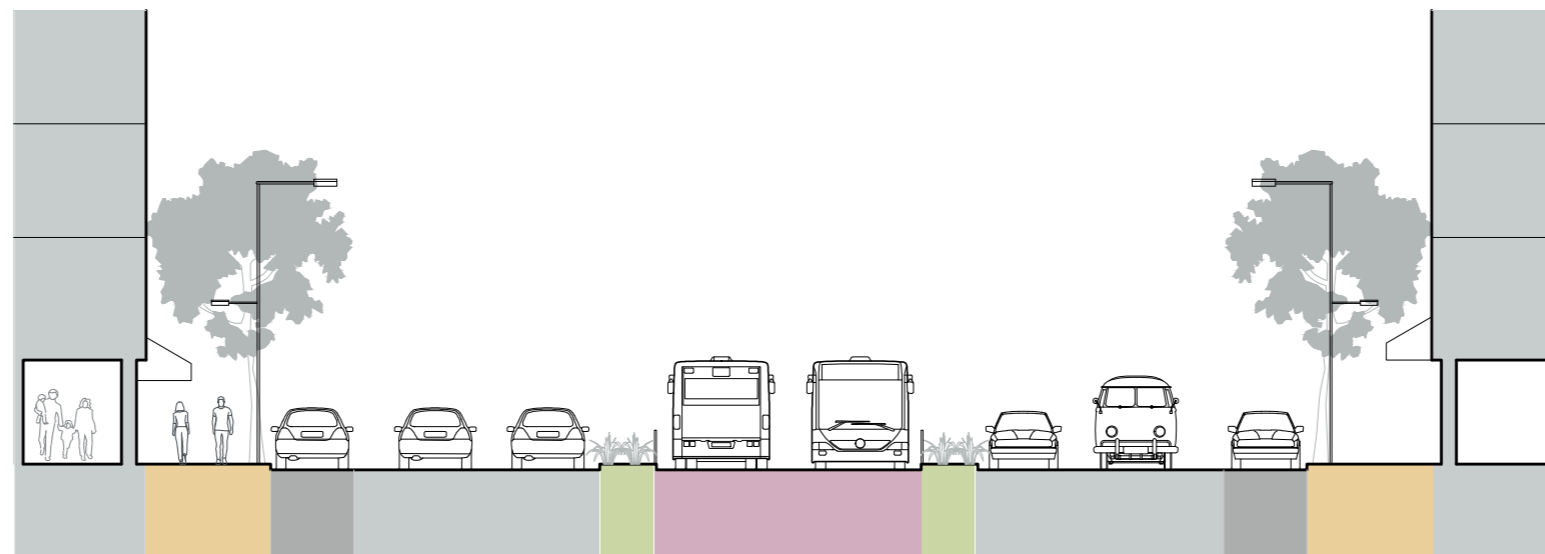

Arcade	Footpath	Parking lane	Carriageway	Median	BRT	Median	Carriageway	Parking lane	Footpath	Arcade
	3.3 m	2.2 m	6.5 m	1.5 m	7 m	1.5 m	6.5 m	2.2 m	3.3 m	

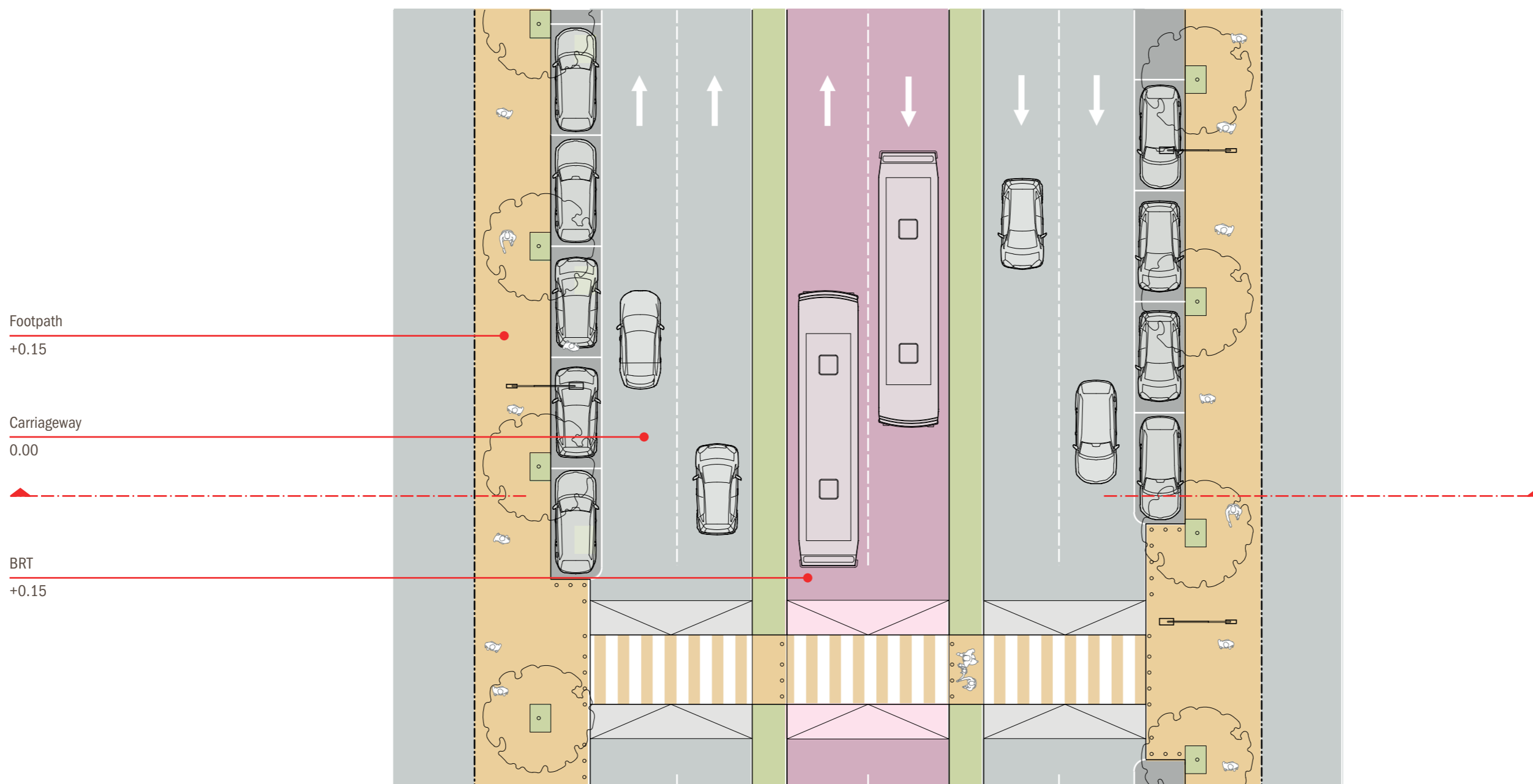

34 m
Option A
At station

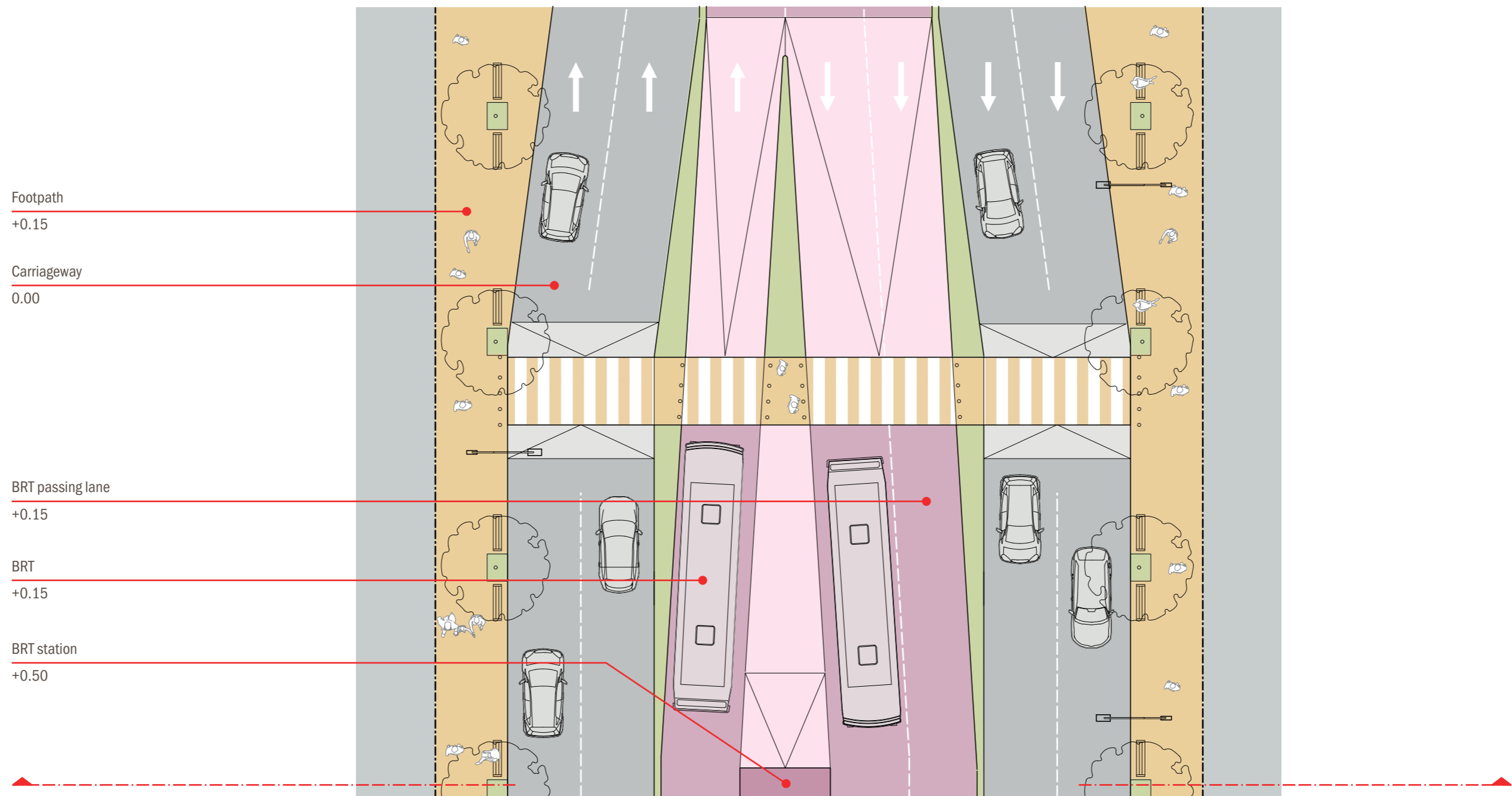
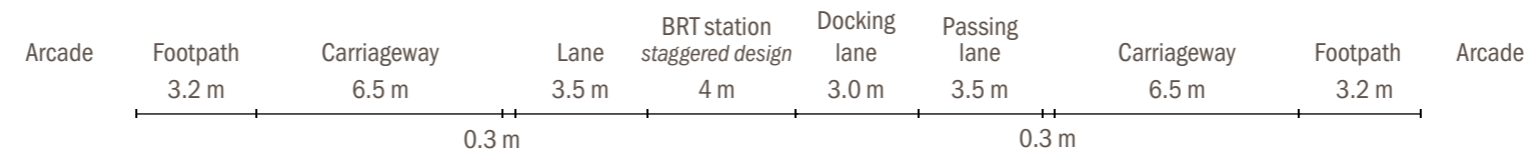
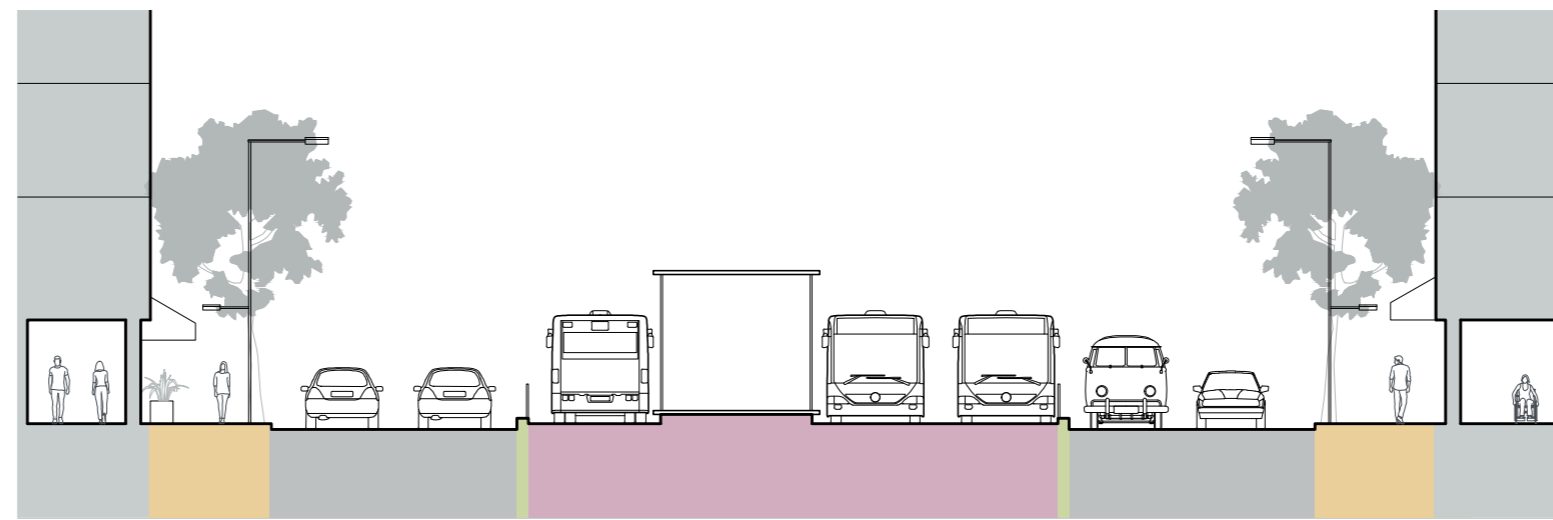

40 m Option A

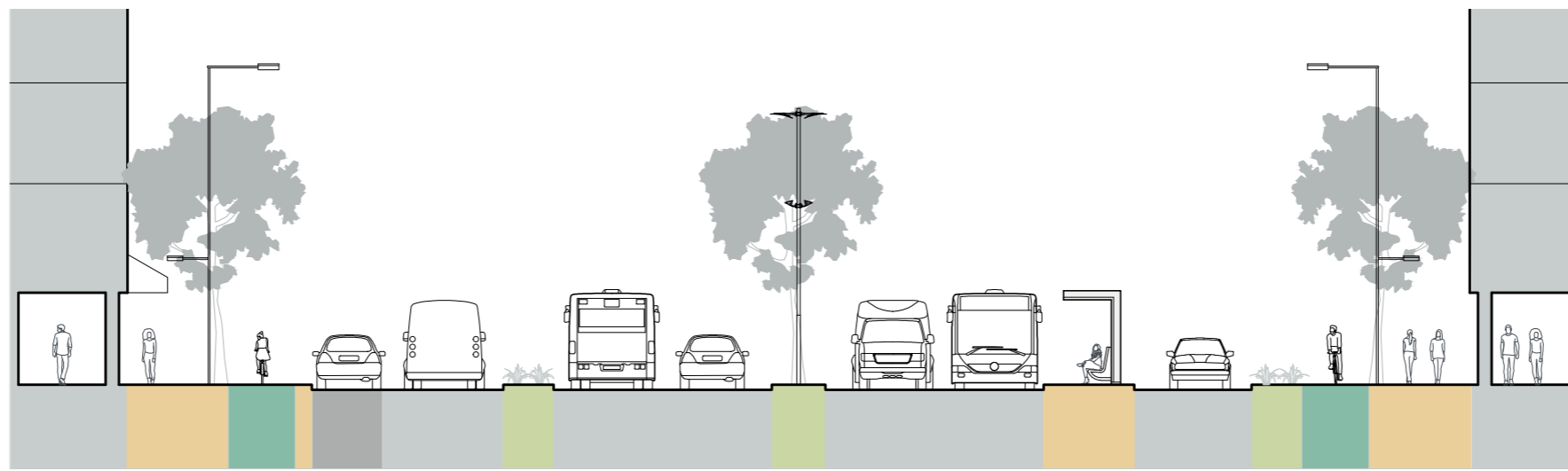

Arcade	Footpath	Cycle track	Parking lane	Service lane	Median	Carriageway	Central Median	Carriageway	Footpath	Service lane	Buffer	Cycle track	Footpath	Arcade
	3 m	2 m	2.2 m	3.5 m	1.5 m	6.5 m	1.6 m	6.5 m	2.7 m	3.5 m	1.5 m	2 m	3 m	

0.5 m

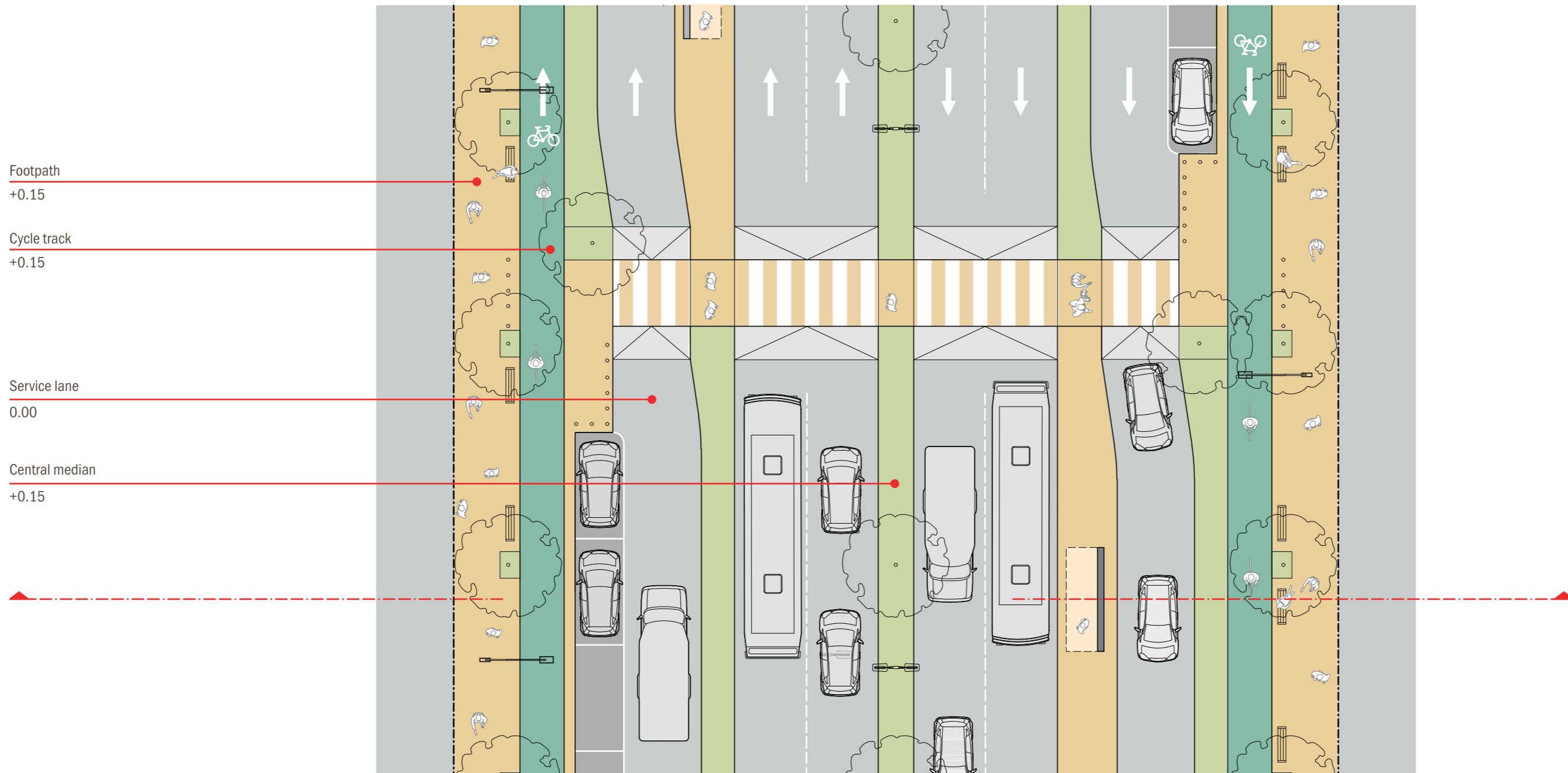

40 m
Option B
Median reserved for BRT

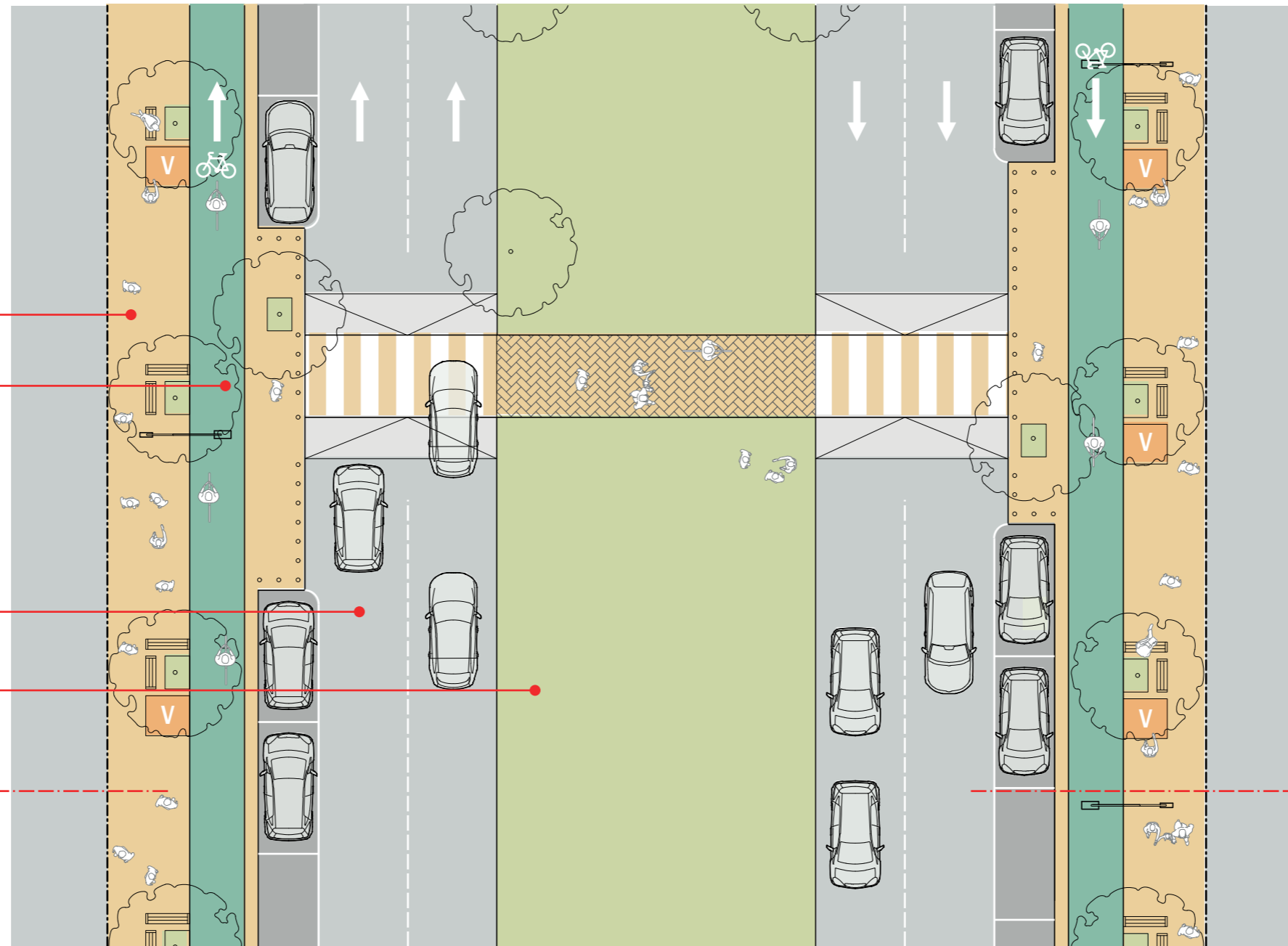
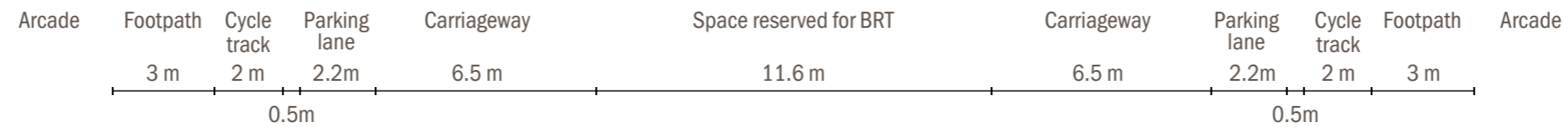
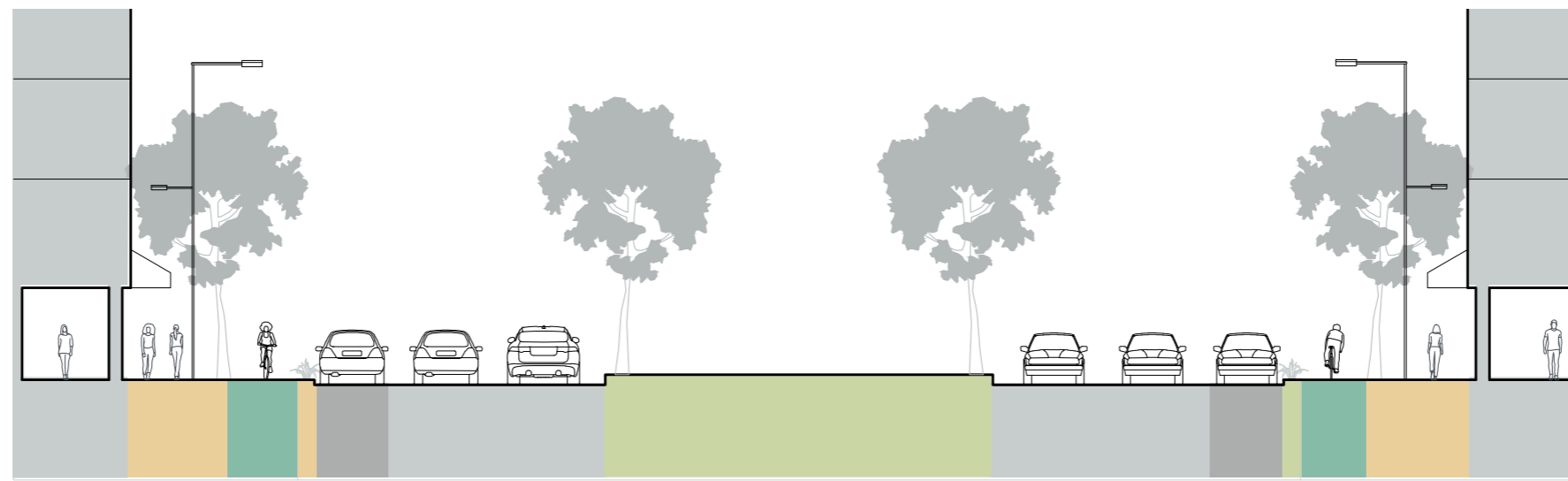

Footpath
+0.15

Cycle track
+0.15

Carriageway
0.00

Space reserved for BRT
+0.15

40 m
Option C
Off station

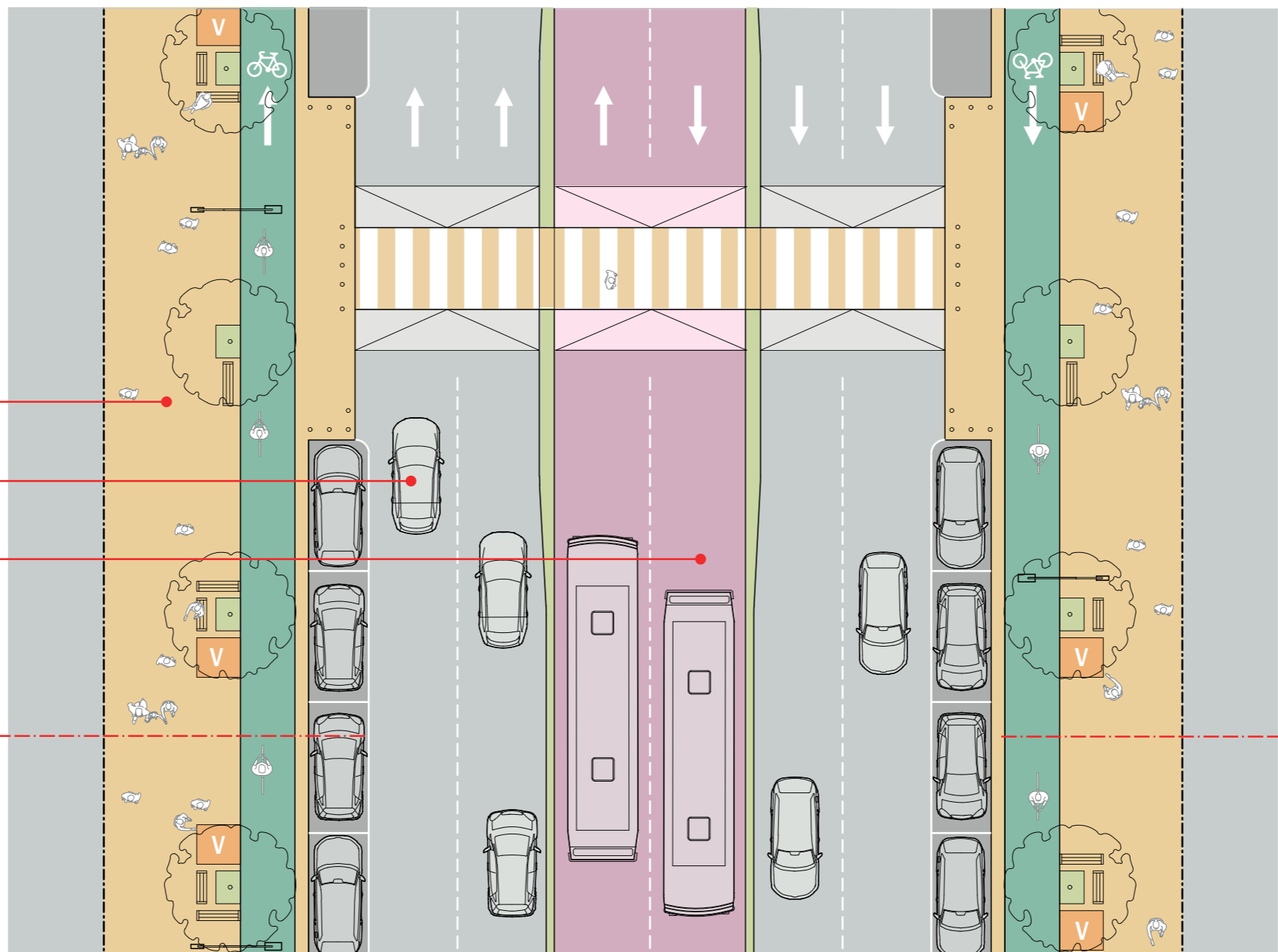
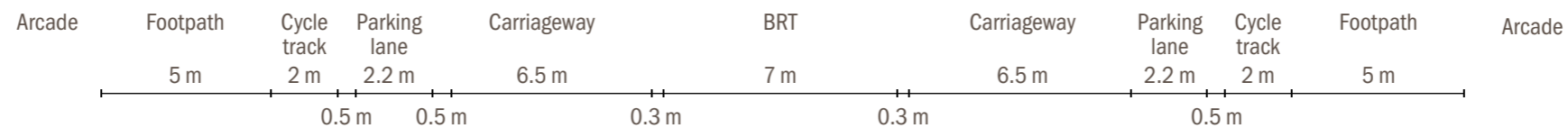
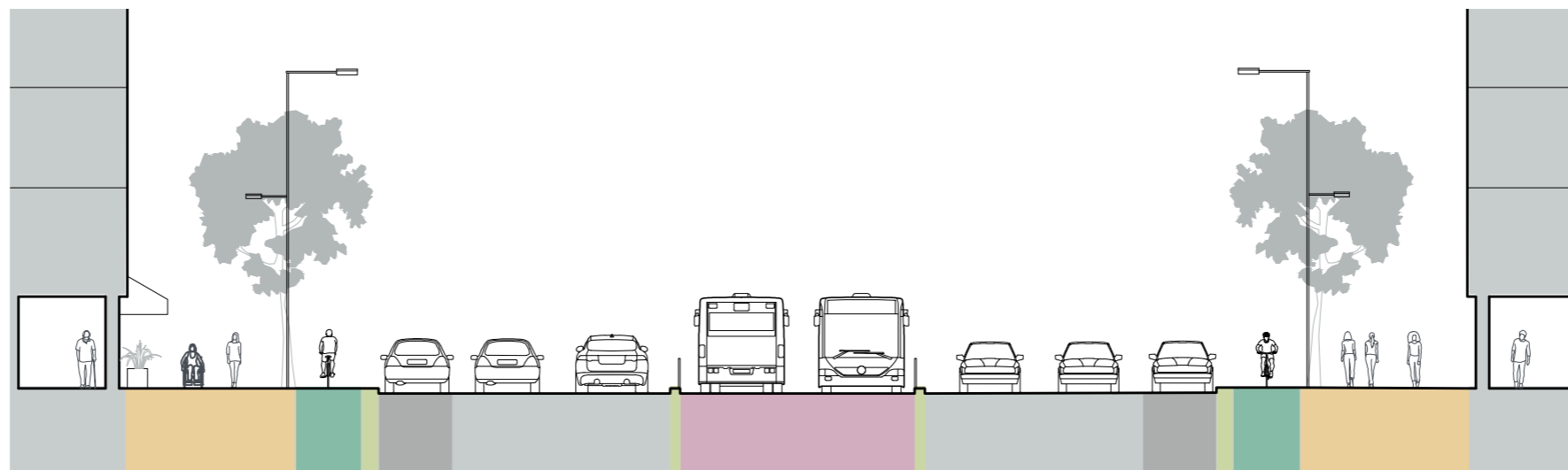

Cycle track

+0.15

Carriageway

0.00

BRT

0.00

40 m
Option C
At station

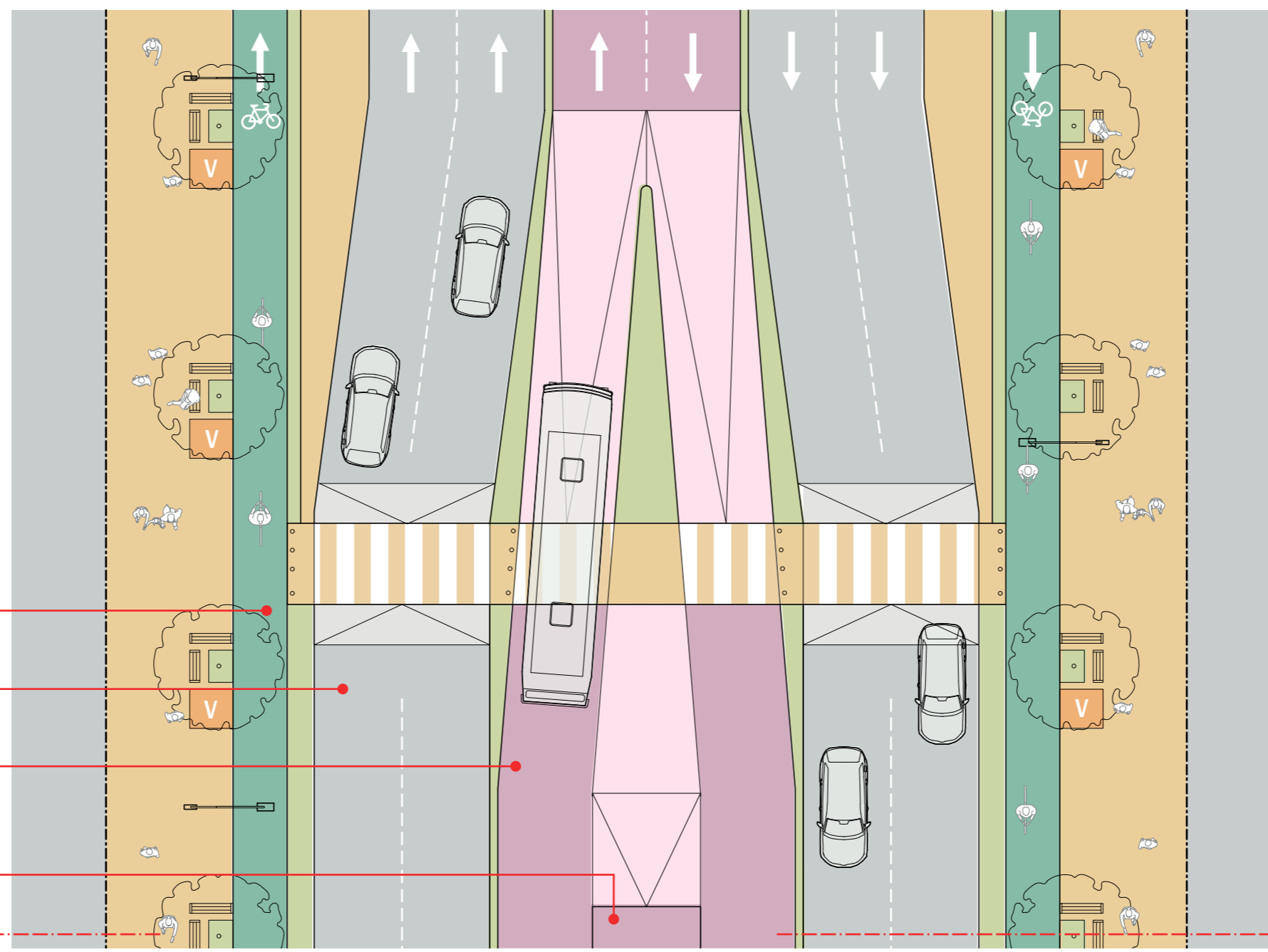
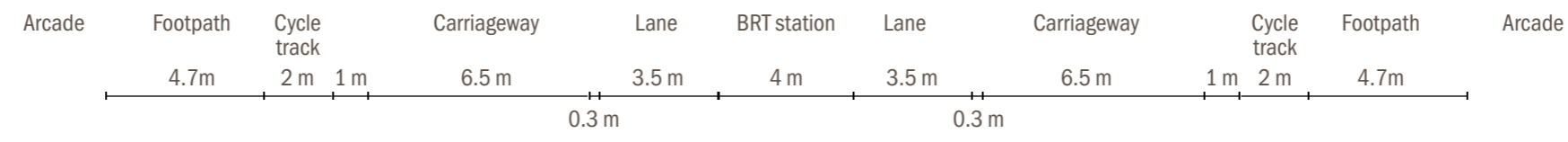
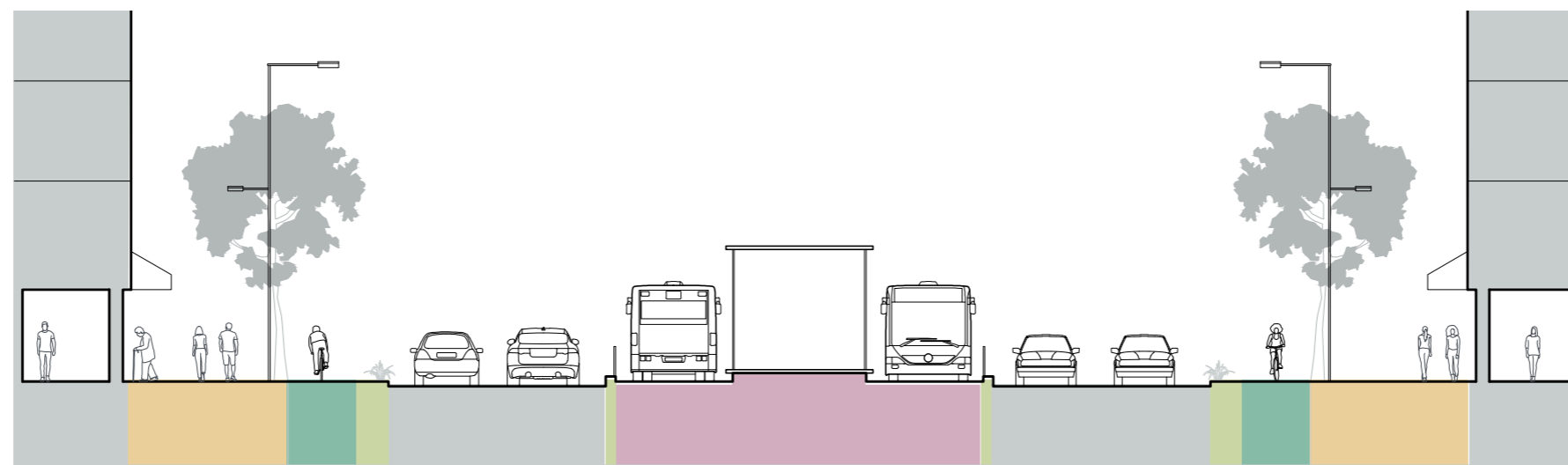

Cycle track
+0.15
Carriageway
0.00
BRT lanes
+0.15
BRT station
+0.50

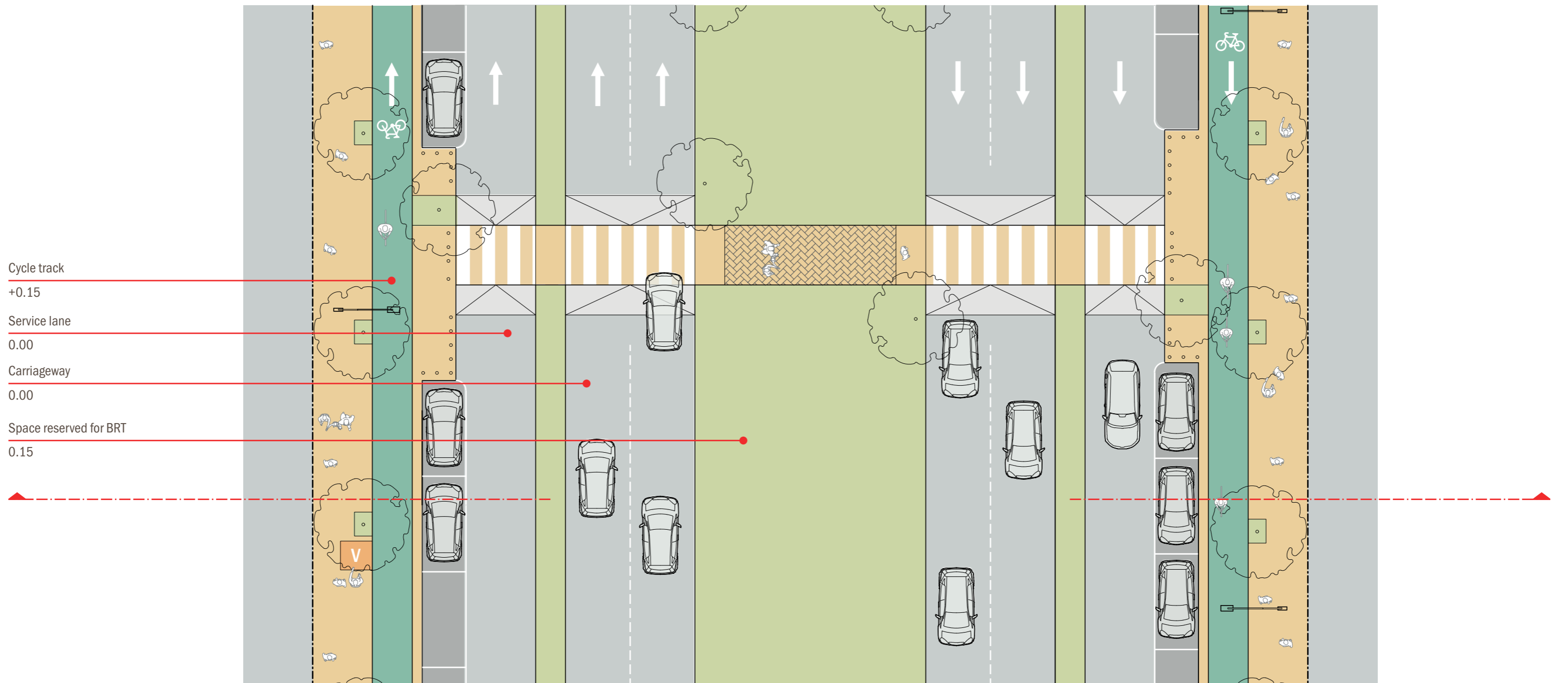
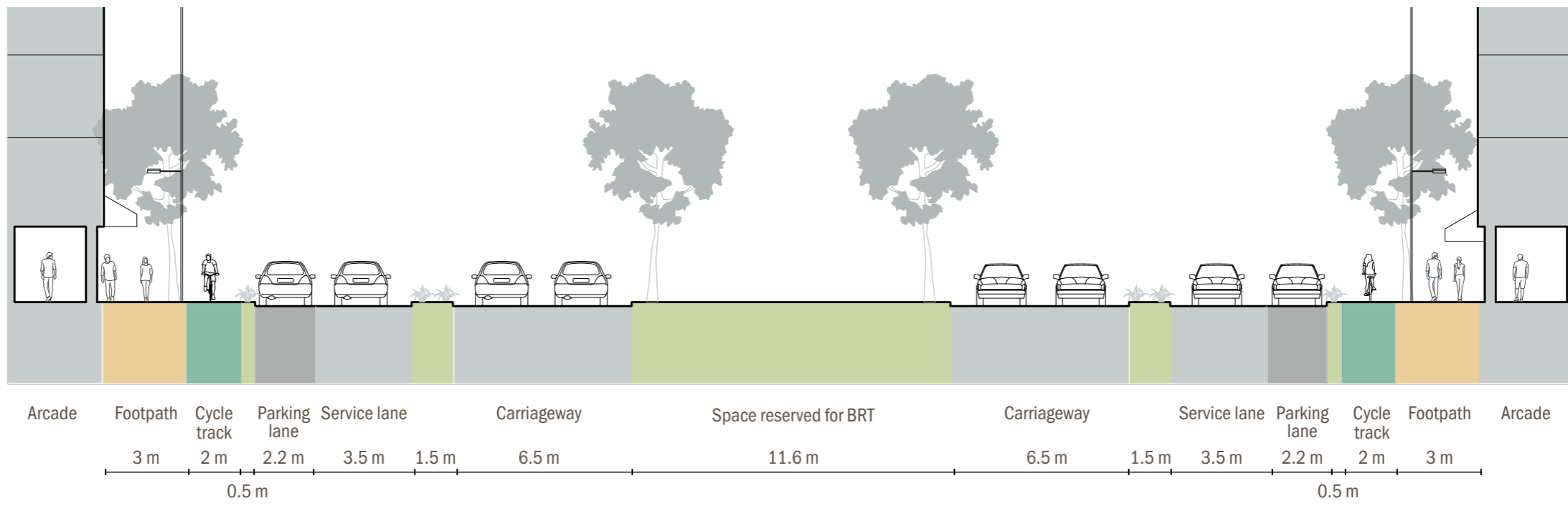

50 m
Option B
Off station



Arcade	Footpath	Cycle track	Parking lane	Service lane		Carriageway	Median	BRT	Median	Carriageway	Service lane	Parking lane	Cycle track	Footpath	Arcade
	4 m	2.5 m	2.2 m	3.5 m	0.8 m	6.5 m	1.5 m	7 m	1.5 m	6.5 m	0.8 m	3.5 m	2.2 m	2.5 m	4 m
	0.5 m										0.5 m				

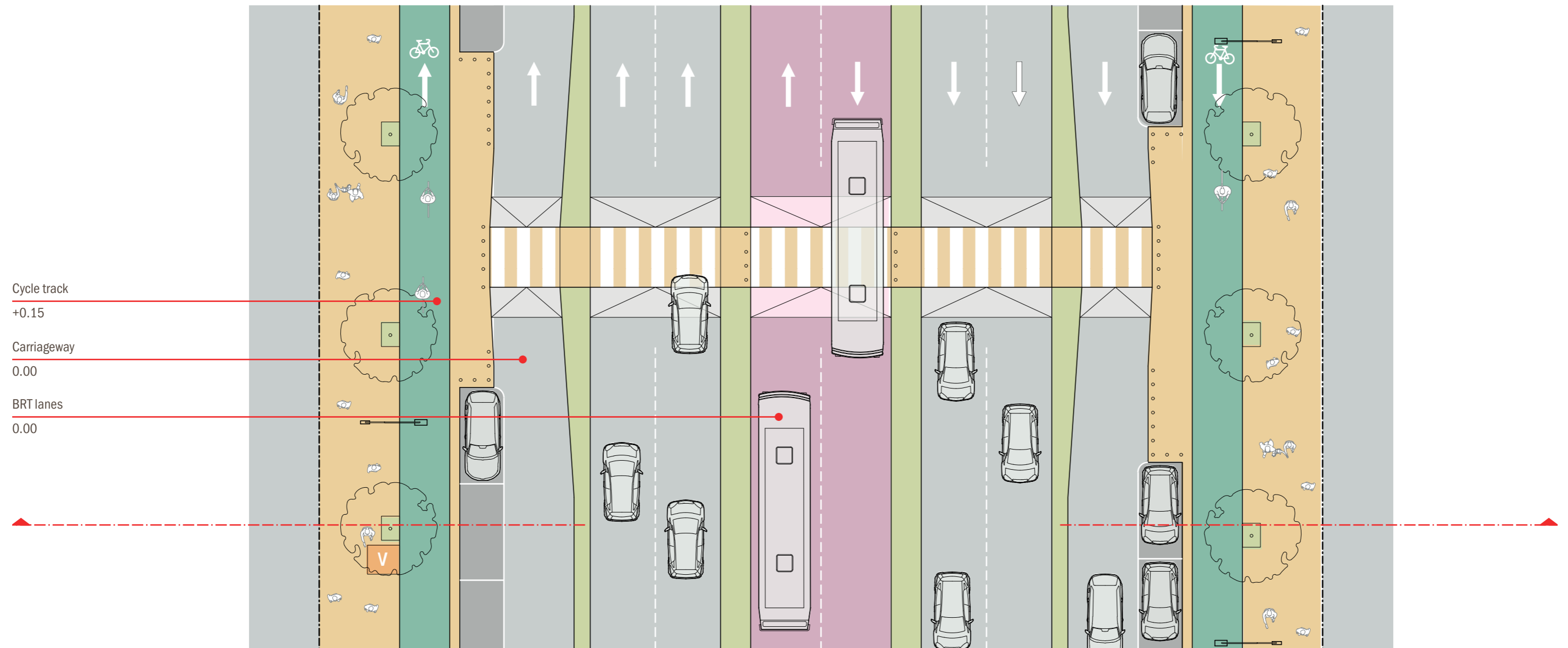

50 m
Option B
At station

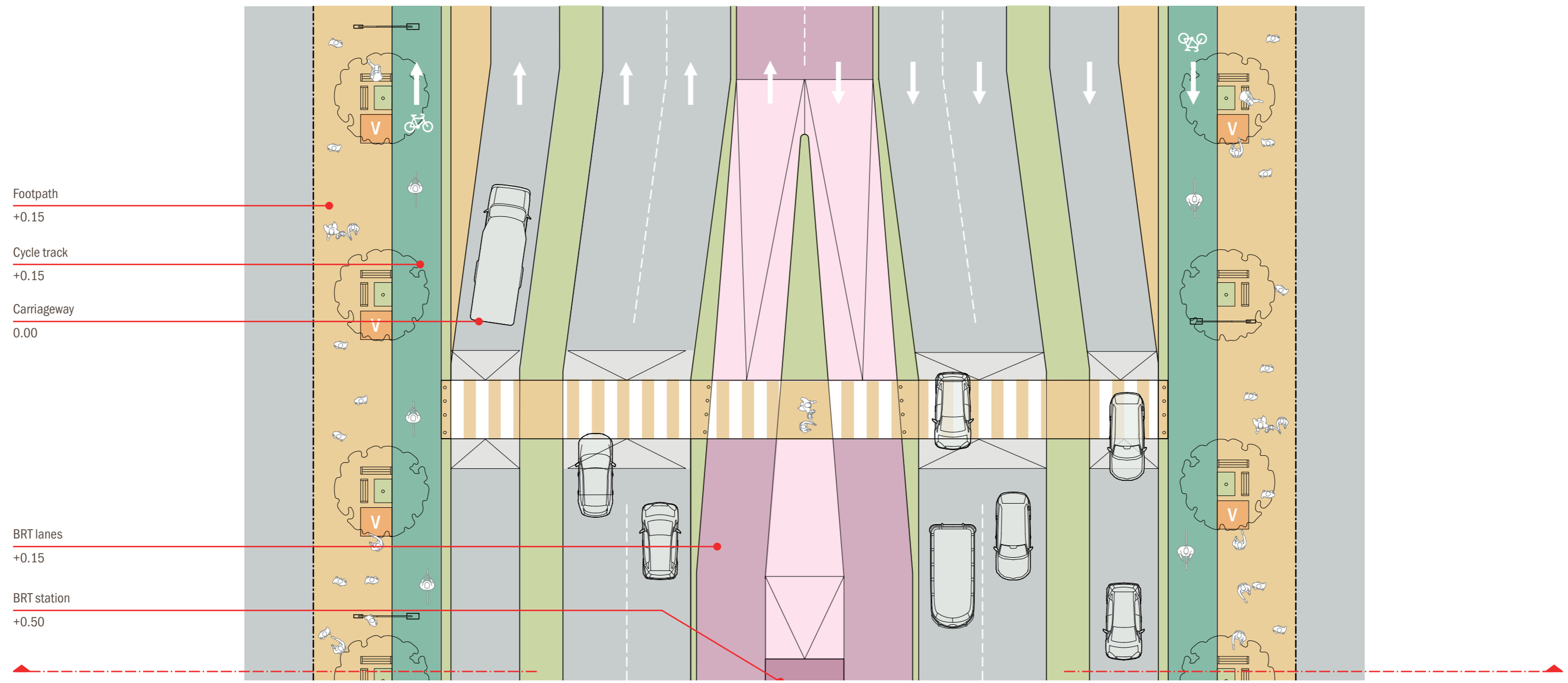
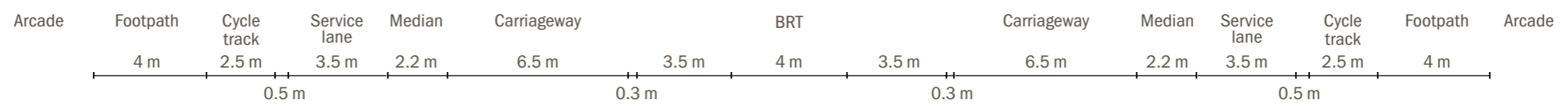
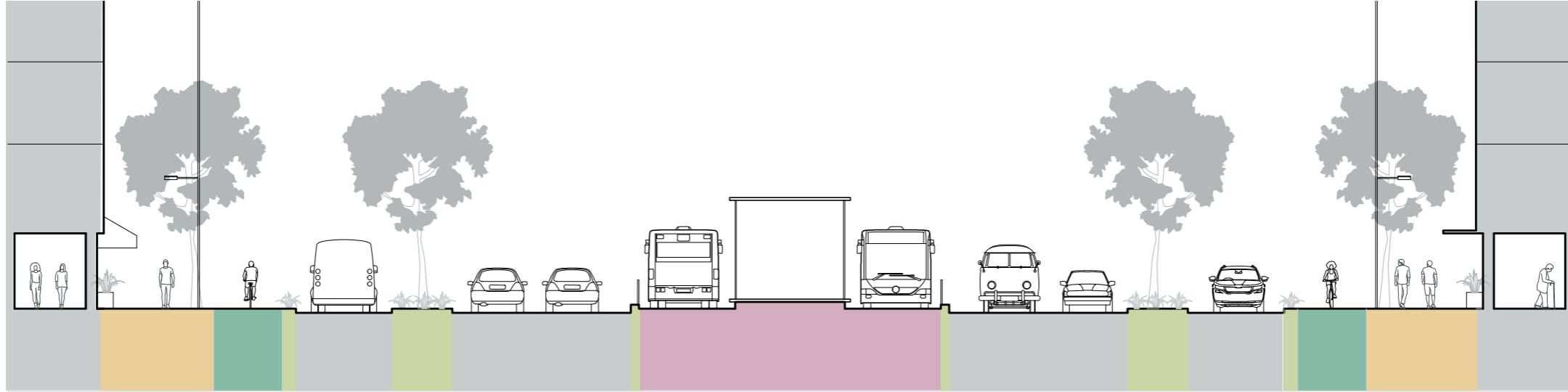

Footpath
+0.15

Cycle track
+0.15

Carriageway
0.00

BRT lanes
+0.15

BRT station
+0.50

60 m
Option A
Off station

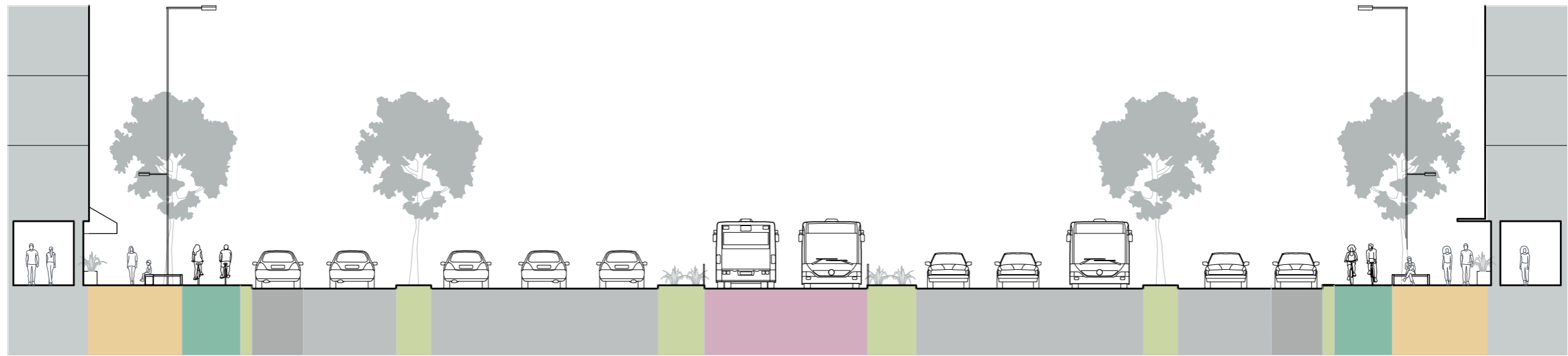

Arcade	Footpath	Cycle track	Parking lane	Service lane	Median	Carriageway	Median	BRT	Median	Carriageway	Median	Service lane	Parking lane	Cycle track	Footpath	Arcade
	4 m	2.5 m	2.2 m	4 m	1.5 m	9.75 m	2 m	7 m	2.1 m	9.75 m	1.5 m	4 m	2.2 m	2.5 m	4 m	
	0.5 m												0.5 m			

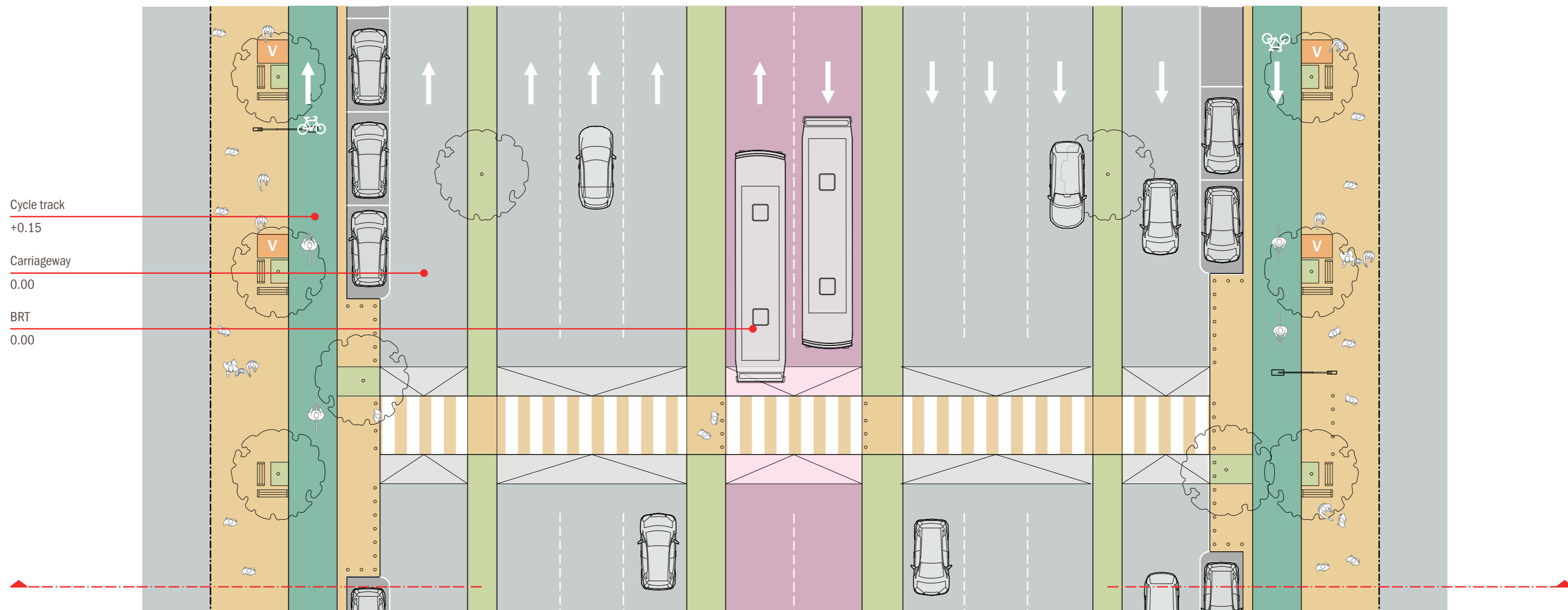

60 m
Option A
At station

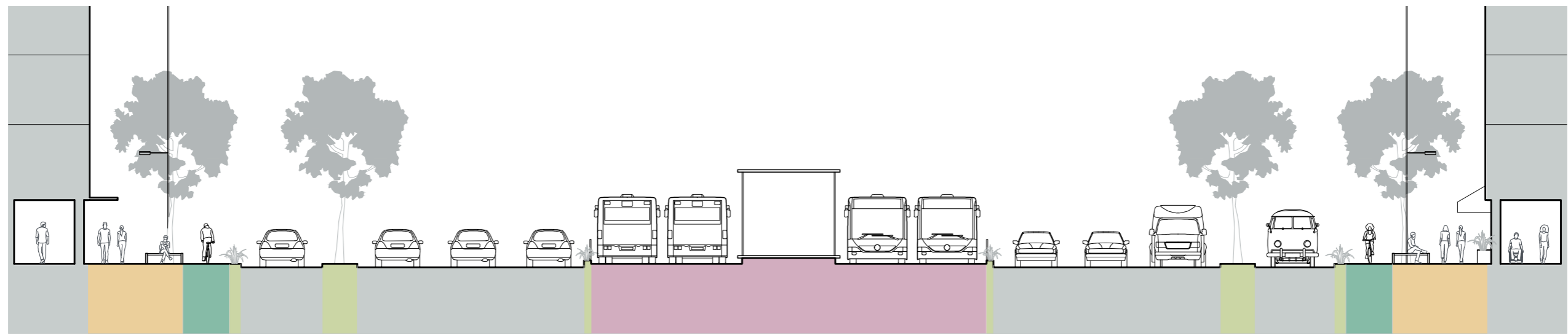

Footpath	Cycle track	Service lane	Median	Carriageway	Passing lane	Lane	BRT station staggered design	Lane	Passing lane	Carriageway	Median	Service lane	Cycle track	Footpath
4 m	2 m	3.5 m	1.5 m	9.75 m	3 m	3.5 m	4 m	3.5 m	3 m	9.75 m	1.5 m	3.4 m	2 m	4 m
	0.5 m				0.3 m				0.3 m			0.5 m		

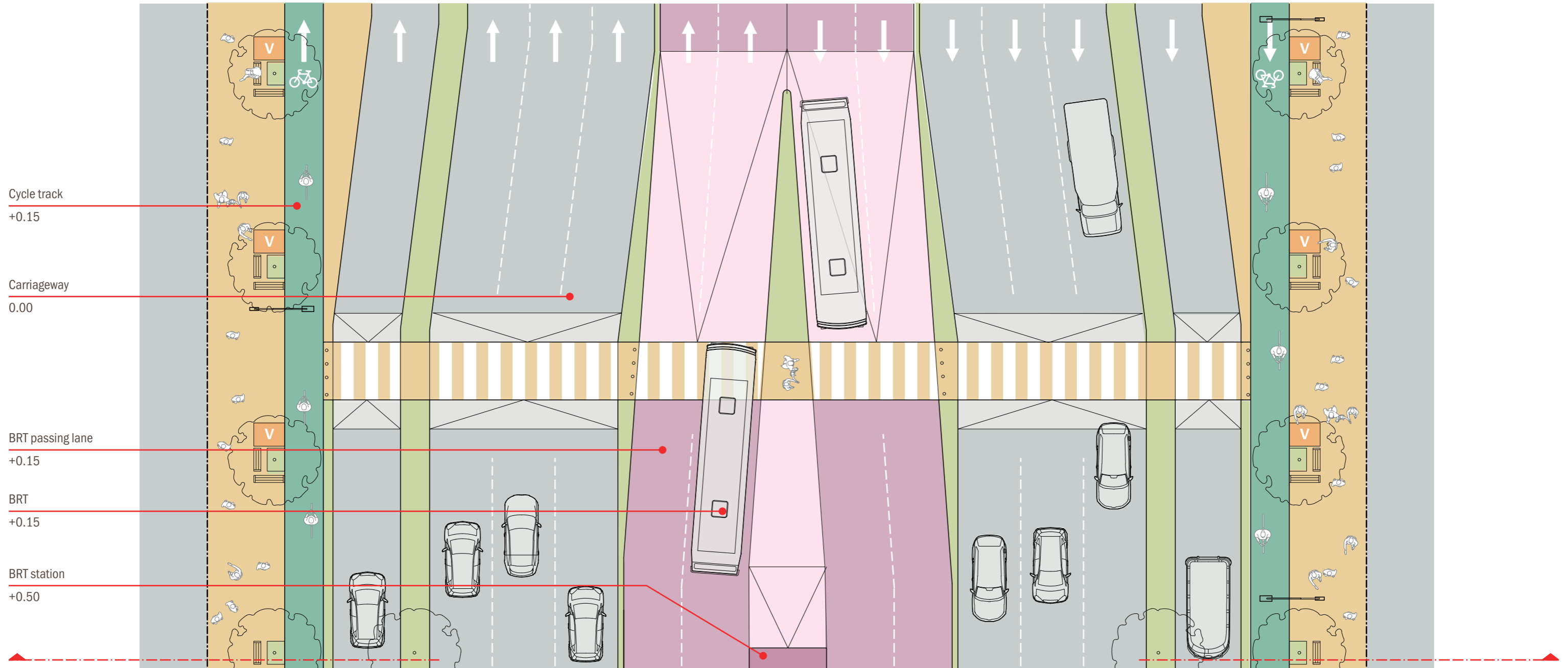



6. INTERSECTIONS

Intersection design has undergone a fundamental shift over the past decades. What was once seen as simply an exercise in processing the highest number of vehicles has now been recast as an exercise in safety. Intersections, by definition, are points of conflict. Experience tells us that the best way to minimise the outcomes of those conflicts is through speed management—not by assigning priority as is traditionally done through traffic control devices.

Intersections, rather than the standard section of a street, are the limiting factor in vehicle capacity. Therefore, intersection design needs to take into account the impact of design choices on mobility. However, this emphasis on mobility should not be confused with privileging private motorised traffic. Instead, it is desirable to design an intersection in such a way that prioritises throughput of public transport, cycles, and pedestrians.

6.1. INTERSECTION TYPOLOGIES

Intersections can take a variety of forms depending on the level of pedestrian activity, bicycle traffic, vehicle volume, presence of BRT, and street cross sections:

- **Signalised intersections** are the preferred configuration for urban intersections of major streets with large volumes of pedestrians and cyclists. All legs are controlled by traffic signals. Signalised intersections provide discrete crossing opportunities for pedestrians and cyclists.
- **Roundabouts** improve safety for vehicles by simplifying the interactions among vehicles at unsignalised intersections. However, they present challenges for pedestrians and cyclists because they increase the size of the intersection and divert NMT movements from their desire lines. Roundabouts are warranted at locations with moderate traffic volumes: up to 15,000 annual average daily traffic (AADT) for a mini roundabout, 25,000 AADT for a single-lane roundabout, and 45,000 AADT for a two-lane roundabout. With higher volumes, roundabouts should be converted to compact signalised intersections without the central traffic circle. Such conversions will reduce delay for vehicle and NMT users alike.
- **Squareabouts** are a means of managing right-turning traffic at large intersections while minimising signal cycle time. Squareabouts make the right-turn phase obsolete by creating right-turn queuing space within the intersection itself. Vehicles queue in this space during one phase and exit during the next phase. Squareabouts are a valuable option on BRT corridors. While the BRT would require the addition of extra phases to a typical four-phase signal cycle, the squareabout accommodates all turning movements in only two phases.
- **Stop-controlled intersections** are appropriate for smaller streets with low to moderate traffic volumes. Stop lines should be provided.
- **Mini roundabouts** are the safest type of intersection on smaller streets.

6.2. OPERATIONS

The capacity of a road facility is the rate at which persons, cyclists, or vehicles can traverse a section of street during a given period of time under prevailing infrastructure, traffic, and control conditions. Delays for NMT users, public transport, and mixed traffic can be minimised through optimal signal phases, determined by the relative volumes of the various movements taking place at an intersection. Use of information technology systems (ITS) can enhance the management of intersections by adjusting signal timings in response to current traffic conditions and prioritising movement of buses.

The simplification of signal cycles through the elimination of turning movements can help reduce delay at intersections, particularly along BRT corridors. As described later in this section, squareabouts combine straight and turning movements, allowing for a two-phase cycle. Signal cycles also can be simplified through changes at the network level. For example, a right turn can be substituted by three left turns. For more information on BRT intersections, see the NaMATA BRT Design Framework.

DESIGN STANDARDS

- ▶ Signal timing should be optimised according to traffic volumes on different legs of the intersection. Pedestrians should be given priority, followed by bicyclists, public transport, and other vehicles in that order.
- ▶ Provide leading pedestrian signals allowing pedestrians to begin crossing before the signals for vehicles along the same leg turn green.
- ▶ The minimum phase duration is determined by the time pedestrians need to cross the street, assuming a walking speed of 1 m/s.
- ▶ Adopt two-phase signal cycles and intersection designs along BRT corridors. Intersections where BRT corridors cross roundabouts should be signalised.
- ▶ Phasing sequences ensure that the final vehicles from each phase are in a different part of the junction from the starting vehicles in the next phase. For example, for four straight-plus-right phases, a counter-clockwise sequence is preferred.
- ▶ Signalised intersections should be fitted with audible pedestrian signals in at least one local language and in English.

6.3. GEOMETRIC DESIGN

The physical layout of an intersection must be designed in conjunction with the signal phasing. The layout is also influenced by the design vehicle, the kind of vehicle that predominantly uses a given street (as opposed to the control vehicle). The design vehicle should be as small as possible, typically a passenger car or small delivery van.

The choice of design vehicle is influenced by the functional classification of a street and by the proportions of the various types and sizes of vehicles expected to use the facility. The control vehicle on the other hand is the largest vehicle that is expected to operate on a given roadway segment at low frequencies. When control vehicles are making turns at an intersection, they can be allowed to encroach to the adjacent lanes to enable them to make the turn movement.

Crossings

Crosswalks delineate an area that is reserved for pedestrian and cycle movement while perpendicular traffic is stopped. They should only be marked where vehicles are required to stop, such as at signalised intersections. At unsignalised intersections, painted crosswalks do not necessarily improve pedestrian safety unless accompanied by a physical measure such as a speed bump or speed table. Stop or yield lines for drivers should be located prior to painted crosswalks.

DESIGN STANDARDS

- ▶ Zebra crossings at all legs of all signalised intersections.
- ▶ Pedestrian crossings aligned with desire lines. People will cross the street using the shortest route, so it is best to accommodate movements along desire lines. Align crossing elements (zebra crossings, median refuges, and kerb ramps) in a straight line and maintain the same width.
- ▶ 5 m wide pedestrian crossings (3 m minimum) and 2 m wide cycle track crossings.
- ▶ Raised crosswalks (tabletop crossings) at +150 mm at unsignalised zebra crossings. This applies to crossings of smaller streets along a corridor, slip lanes, and elsewhere. Signalised crossings may be raised as well. The entire intersection may be raised.
- ▶ Pedestrian refuge islands separate conflicts, so pedestrians can judge whether it is safe to cross by looking at and analysing fewer travel lanes and directions of traffic at a time. Provide refuge islands where there are more than three lanes total to cross.

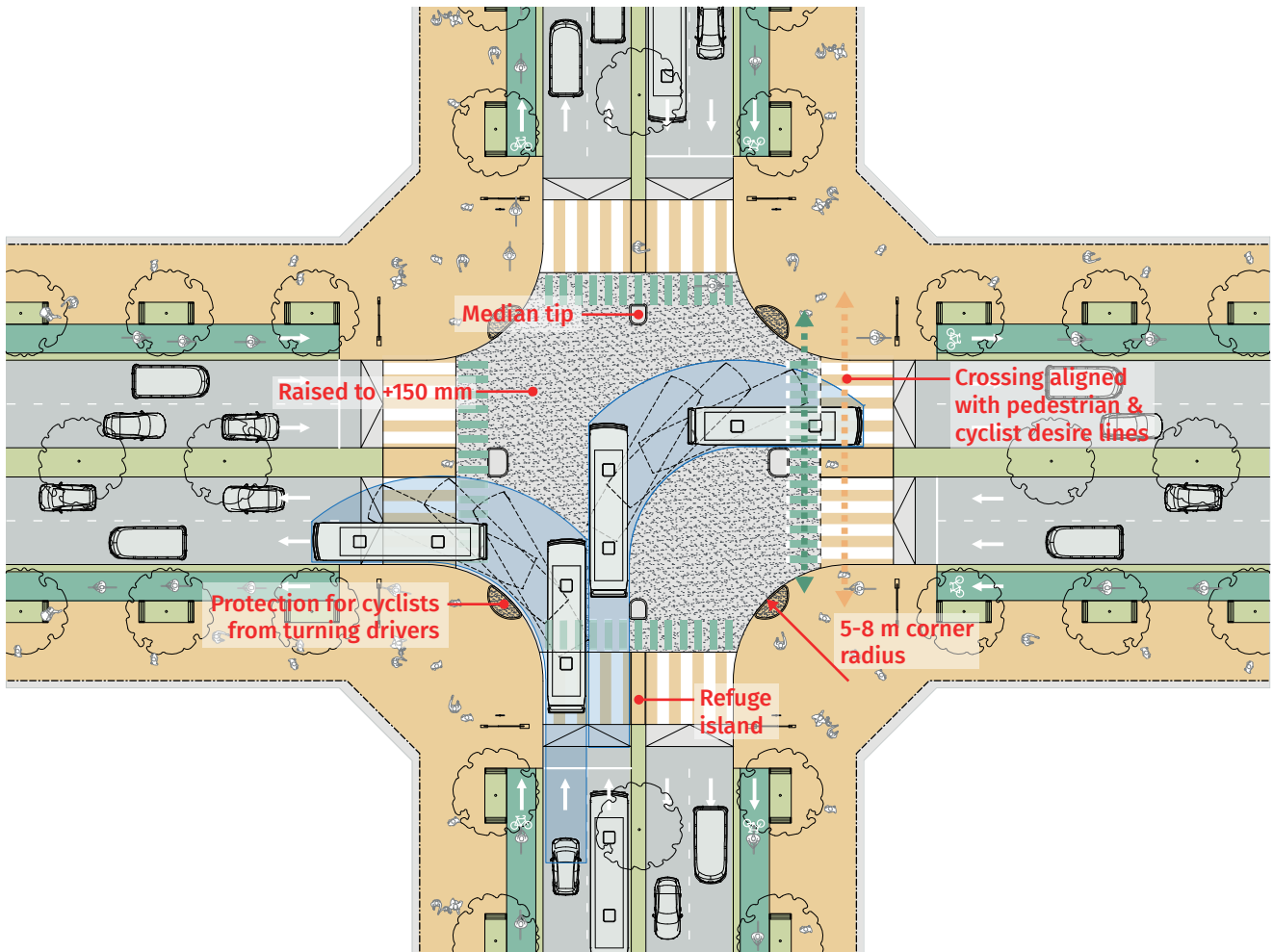

Figure 77. Signalised intersection design elements.

- ▶ Provide bicycle facilities through intersections. Protect cyclists from drivers, especially turning drivers. Direct cyclists through pedestrian areas. Include slow, shared zones where modes and directions interact.
- ▶ “Median tips” where there is a zebra crossing and a median at an intersection
- ▶ Stop lines perpendicular to the travel lane and set back at least 3 m from the zebra crossings.
- ▶ Tall, bushy plants should be avoided immediately adjacent to refuge islands because they obstruct pedestrian visibility. In the case of triangular islands adjacent to free left turn lanes, the island must remain free of landscaping and fencing in order to serve as a refuge for pedestrians.

Turning radius

The concept of the turning radius is relevant in the context of designing street corners and left turn pockets. Larger vehicles require more space in order to take a turn, so intersection designs need to take into account the size of vehicles that are expected to pass through an intersection.

Since larger turning radii encourage faster vehicle speeds, tighter corners are preferred because

they improve safety for pedestrians and cyclists. Smaller radii reduce vehicle speeds, minimise crossing distances, and encourage driver yield behaviour.

While larger streets need to take into account the turning radius requirements of buses and trucks, the effective turning radius is often much larger than the radius of the built kerb. The design of the kerb should assume that vehicles make the largest turn possible. The corner radii listed below can be adjusted in the case of skewed intersections.

DESIGN STANDARDS

- ▶ For local streets that cater to light vehicles, as well as intersections of major streets with local streets, a 3 m kerb radius is appropriate.
- ▶ For streets with large vehicles, use an 8 m radius when turning into one lane and a 5 m radius when turning into more than one lane.
- ▶ Protected configuration of the cycle track at locations where vehicles turn.

Bollards

Bollards help define refuge islands and other pedestrian spaces and prevent vehicles from driving over these spaces. Bollards are especially helpful when a pedestrian area is at the same level as the surrounding street surface. Possible shapes range from slender posts to larger and heavier obstacles that can double as seats.

DESIGN STANDARDS

- ▶ A minimum width of 900 mm between at least one set of bollards is required for the passage of wheelchairs at pedestrian crossings.
- ▶ At entrances to cycle tracks, 1.2 m is preferred between bollards. A width of 1.5 m is required for 3-wheelers and trailers.

Intersection alignment

The carriageway can be widened at intersections to provide additional queuing space for vehicles, which reduces overall signal time. Where the additional space is provided, the street's cross section usually becomes asymmetrical—even if the regular street section is symmetrical—in order to claim the additional space evenly from both sides of the cross section instead of eating deeply into the pedestrian/cycle space only on one side. The number of straight-bound lanes entering an intersection should equal the number of outgoing lanes in the same direction. Otherwise, the intersection may become congested as vehicles try to merge into the narrower outgoing carriageway.

DESIGN STANDARDS

- ▶ The physical layout of signalised intersections must be designed in conjunction with traffic signal timing and phasing for users.
- ▶ Equal number of straight-bound lanes entering an intersection and outgoing lanes in the same direction.
- ▶ Streets at an intersection should join at right angles, or as near to a right angle as possible.
- ▶ If more than four legs join at the intersection, explore solutions to reduce the number of intersecting legs.

- ▶ One receiving lane at a T-junction as there will ever only be one driver turning into it at a time.
- ▶ 1:2 transition when a turn lane is added.
- ▶ The entire intersection can be raised to the level of the footpath (typically +150 mm) to improve safety. Vehicles from all directions pass over a ramp as they enter the intersection, causing them to slow down.

Left turn pockets

Left turn pockets can increase intersection capacity by allowing vehicles to make free left turns. However, if not designed appropriately, they can compromise pedestrian safety. Traditionally, left turn lanes have been designed with a circular geometry. However, such a design is unsafe for pedestrians because it allows for fast vehicle movements. The preferred design incorporates a 30° angle of approach. Since vehicles enter the outgoing leg at a more abrupt angle, they are compelled to reduce their speeds.

The design should assume that a large vehicle completes the turn in the outermost lane of the exit leg but may enter the central lane while completing the turn. Otherwise, the left turn pocket becomes so large that smaller vehicles are able to travel at full speed around the corner.

DESIGN STANDARDS

- ▶ 30° angle of approach to encourage moderate vehicle speeds, with a 20 m entry radius and 8 m exit radius.
- ▶ 4 m vehicle lane.
- ▶ Tabletop crossing for pedestrians and cyclists, with ramps for vehicles.

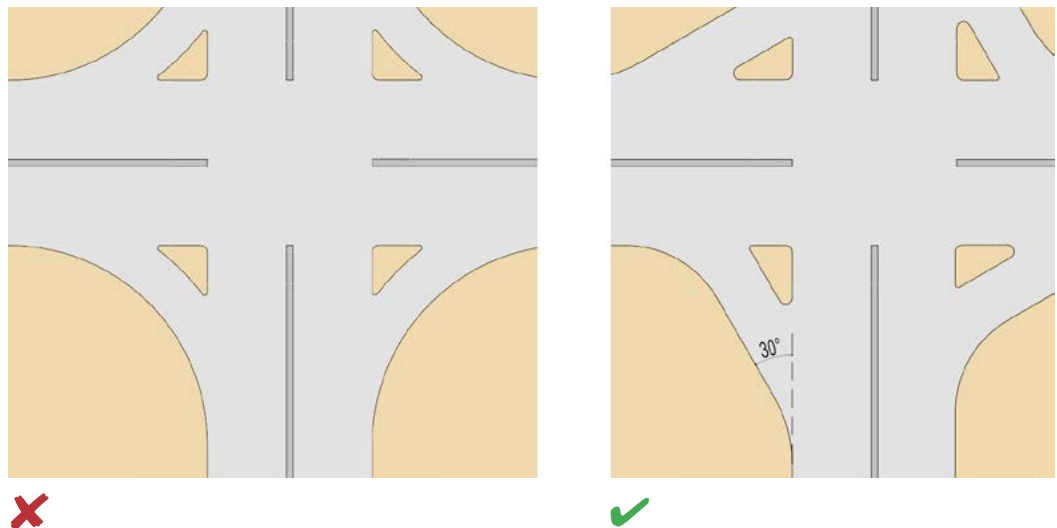

Figure 78. A 30° angle of approach at left turn pockets encourages moderate speeds.

Roundabouts

Roundabouts can improve safety for vehicles at unsignalised intersections with moderate vehicle volumes. Roundabouts increase walking and cycling distances and should be avoided where NMT volumes are high. Roundabouts need to include safety elements for pedestrians and cyclists. The cycle lane should be protected from motorised traffic in the roundabout through the provision of a buffer zone. Since the intersection is unsignalised, pedestrian and cycle crossings should be raised to the level of the footpath, with ramps for vehicles.

DESIGN STANDARDS

- ▶ Inner circle radius as large as possible.
- ▶ No more than two approach lanes per direction. If there are three or more lanes, use a signalised intersection design. The number of circulating lanes should be equal to the number of lanes per direction on the largest carriageway of the intersecting legs.
- ▶ Adopt a maximum of 2 lanes circulating the roundabout.
- ▶ Circulating lane width of 4 m.
- ▶ 5 m offset between the circulating lanes and the crossing to allow a vehicle to stop for pedestrians and cyclists on the exit leg without blocking the roundabout.
- ▶ Raised pedestrian and cycle crossings at +150 mm.
- ▶ Roundabouts can be applied in areas where the volume of pedestrians is low and where there is sufficient space to accommodate vehicle and NMT elements in the roundabout design.

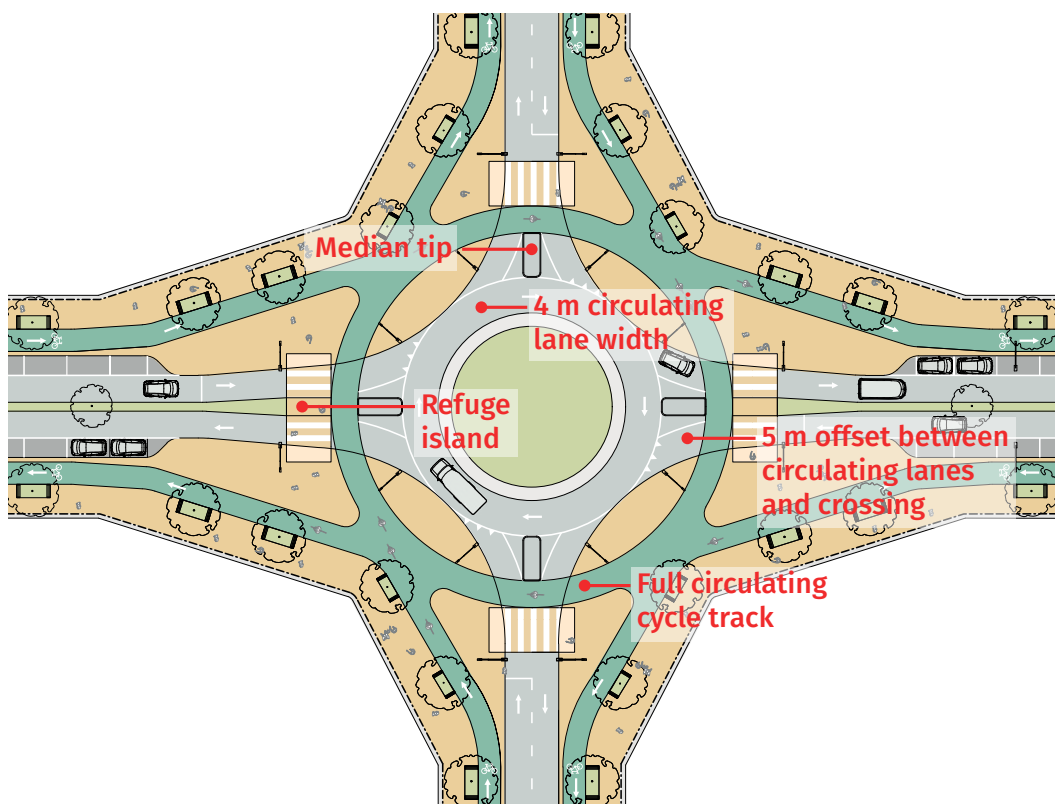

Figure 79. Roundabout design elements: single-lane roundabout.

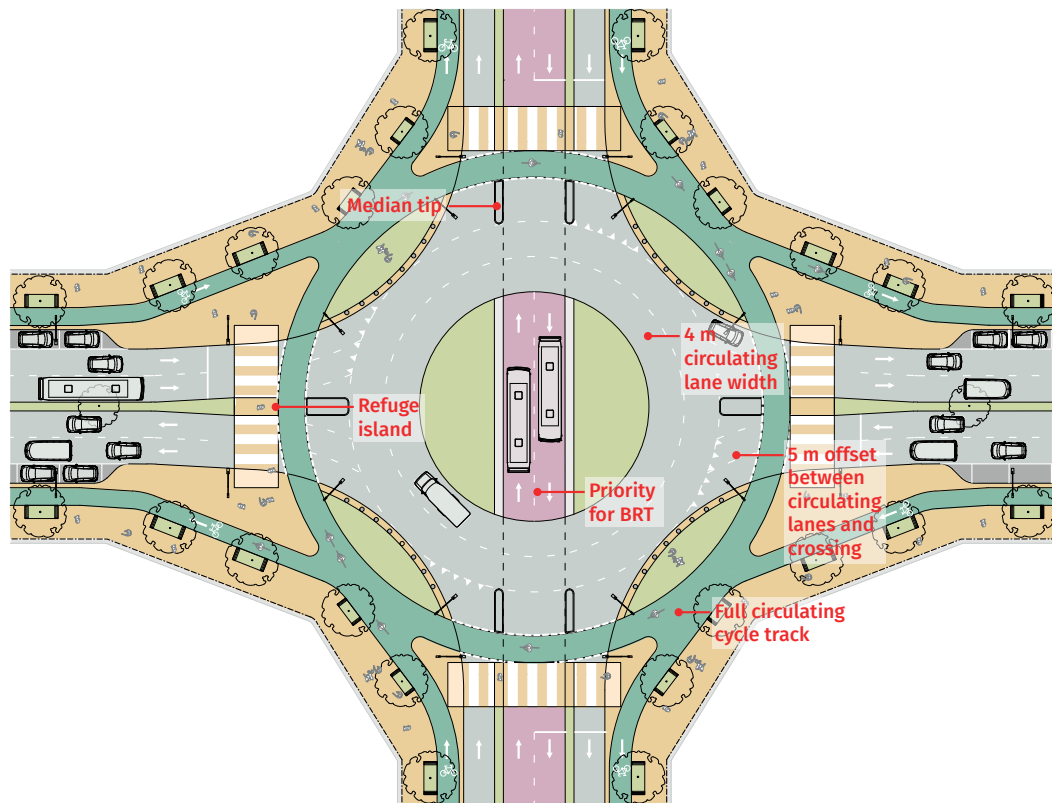

Figure 80. Roundabout design elements: dual-lane roundabout with BRT.

Intersections with BRT

BRT intersections should be designed to operate with two-phase signal cycles, reducing delays for buses and mixed traffic alike. Turns along BRT corridors can be managed through the following approaches:

- Two-phase signal cycles combine straight-bound BRT and mixed traffic movement. Right turns are accomplished through the network (e.g., three left turns).
- Signalised U-turns allow vehicles to reach the opposite side of the corridor. They also accommodate right turning vehicles (e.g., U-turn plus left turn).
- Squareabouts make the right-turn phase obsolete by creating right-turn queuing space within the intersection itself. Vehicles queue in this space during one phase and exit during the next phase. BRT buses merge with the mixed traffic when moving around the central island.

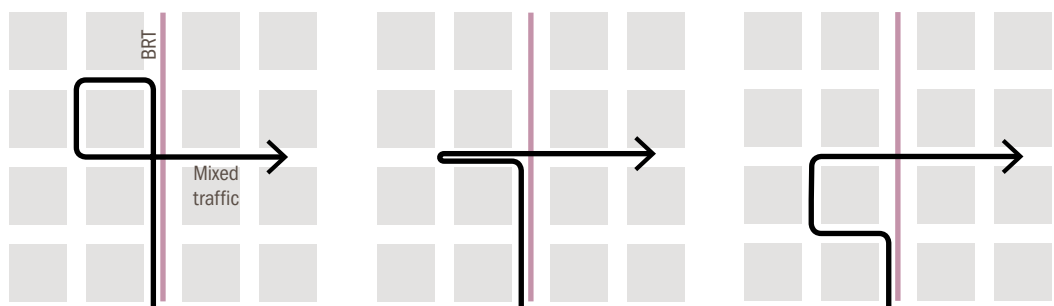

Figure 81. Alternatives to right turns across median BRT lanes.

DESIGN STANDARDS

- ▶ Adopt two-phase signals at BRT intersections. Eliminate right turns across the BRT lanes. Additional phases may be provided where BRT buses need to turn.
- ▶ In squareabout intersections, size the queueing space per expected turn volumes. Use corner radii of 8 m for the central island.
- ▶ Position U-turn lanes on the outer side of the carriageway to improve visibility of turning vehicles for bus drivers and allow for an adequate U-turn radius.



Figure 82. Alternative to right turns across BRT lanes.



Figure 83. Squareabout intersection with two-phase signal cycle permitting BRT and mixed traffic turning movements together.

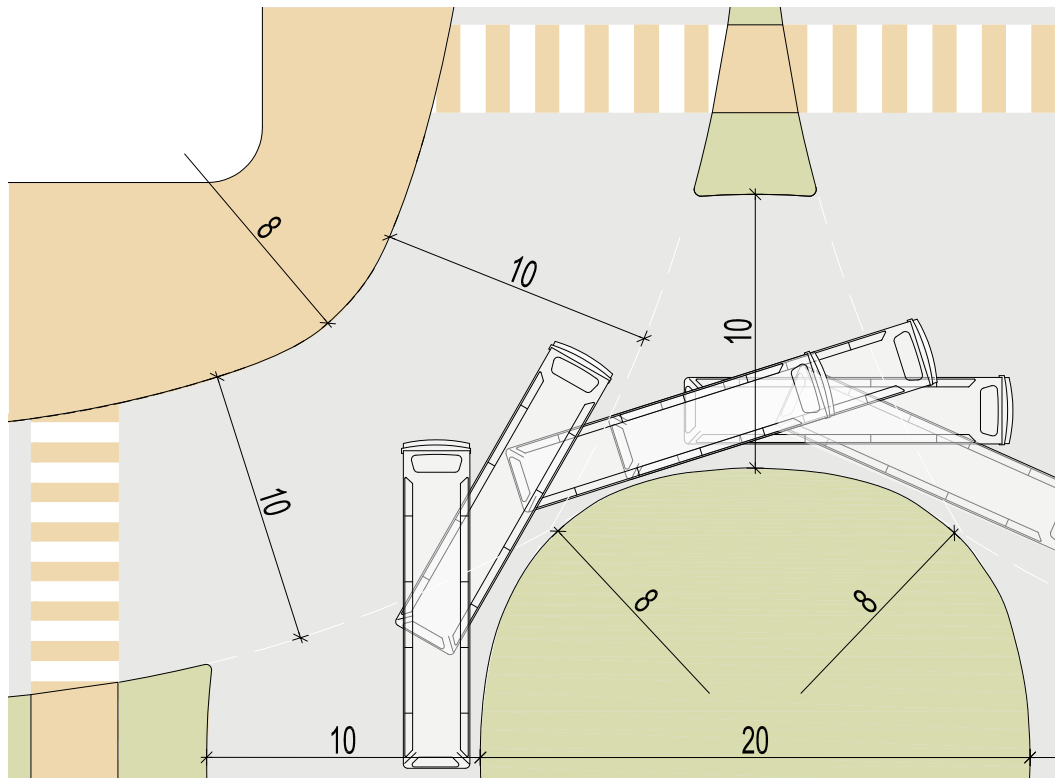

Figure 84. Squareabout configuration to accommodate BRT turning movements.

Grade separation

In general, urban intersections should be at-grade so as not to disrupt the urban fabric, public space, and socioeconomic activities. Grade separation is not justified to facilitate vehicle flow. This simply induces more traffic and increases speed at the overpass, which decreases safety.

Cases where grade separation may be justified include BRT-only flyover to give priority to BRT buses, NMT-only bridge or tunnel connecting parks and greenways, and changes in elevations where people already go up or down.

DESIGN STANDARDS

- The clear height under the grade separator shall be at least 5.5 m.

Shared space intersection

10 m x 10 m

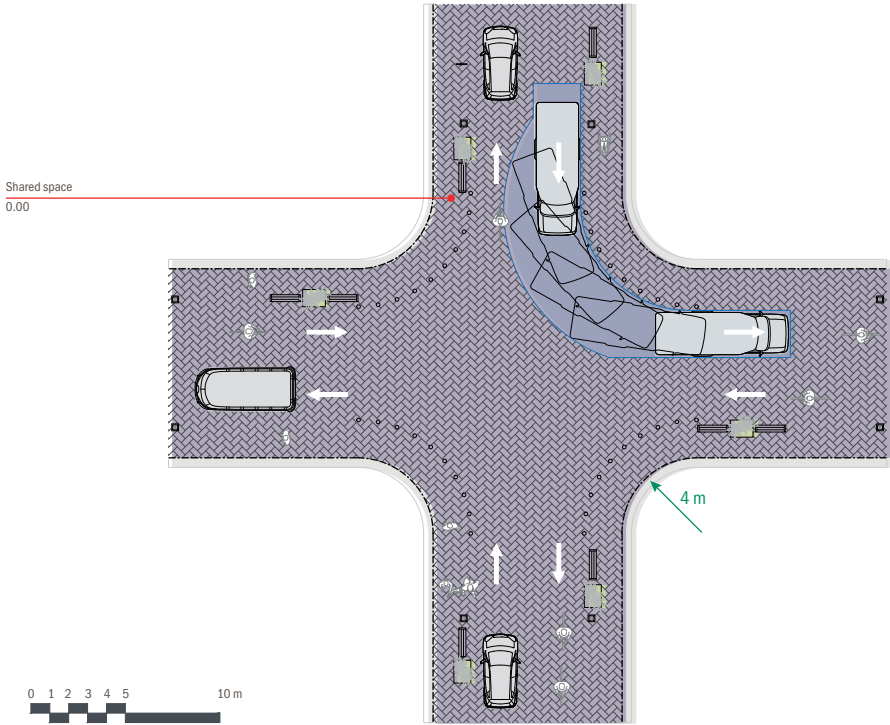

Four-way intersection

20 m x 20 m

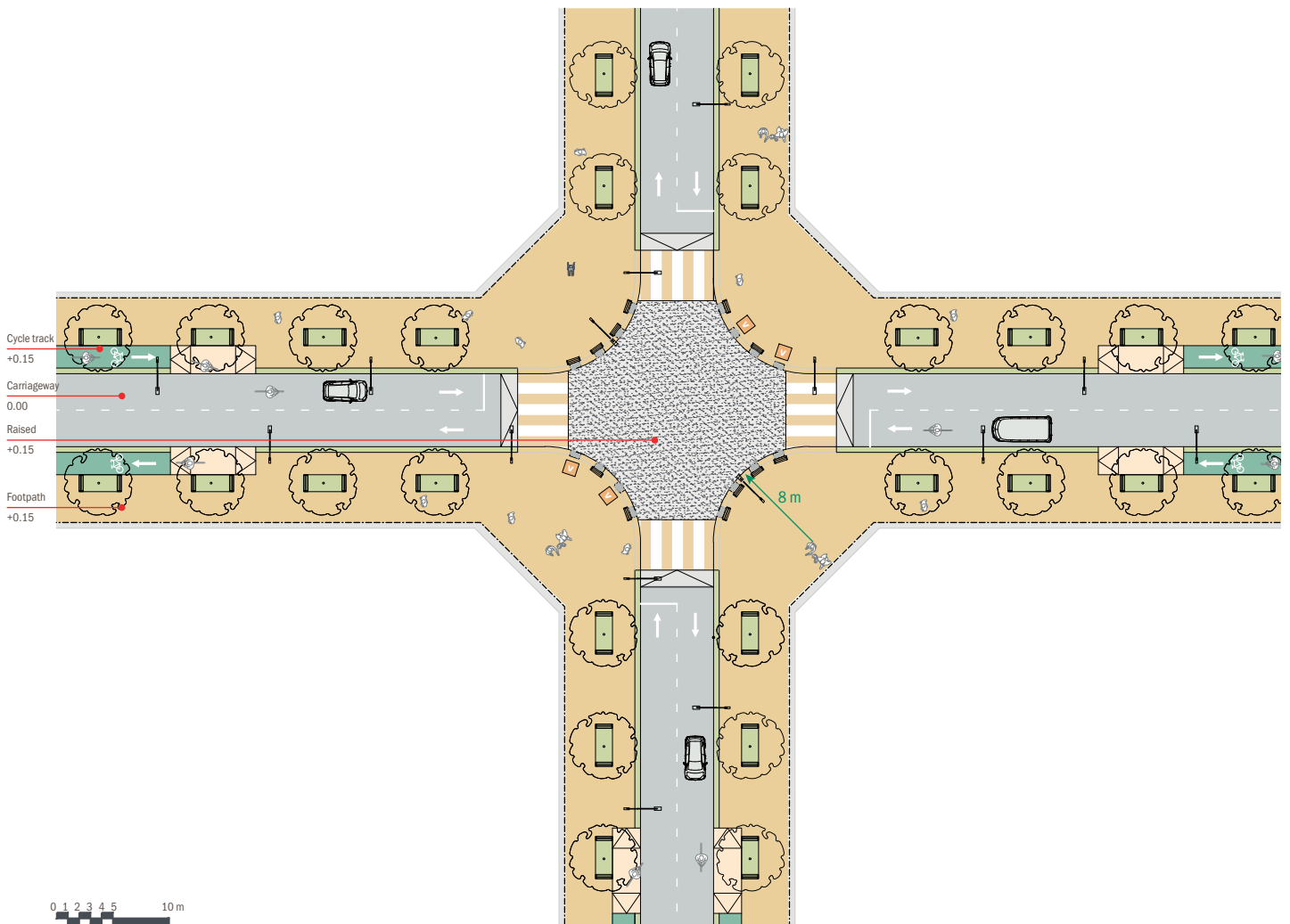

Mini roundabout

20 m x 20 m

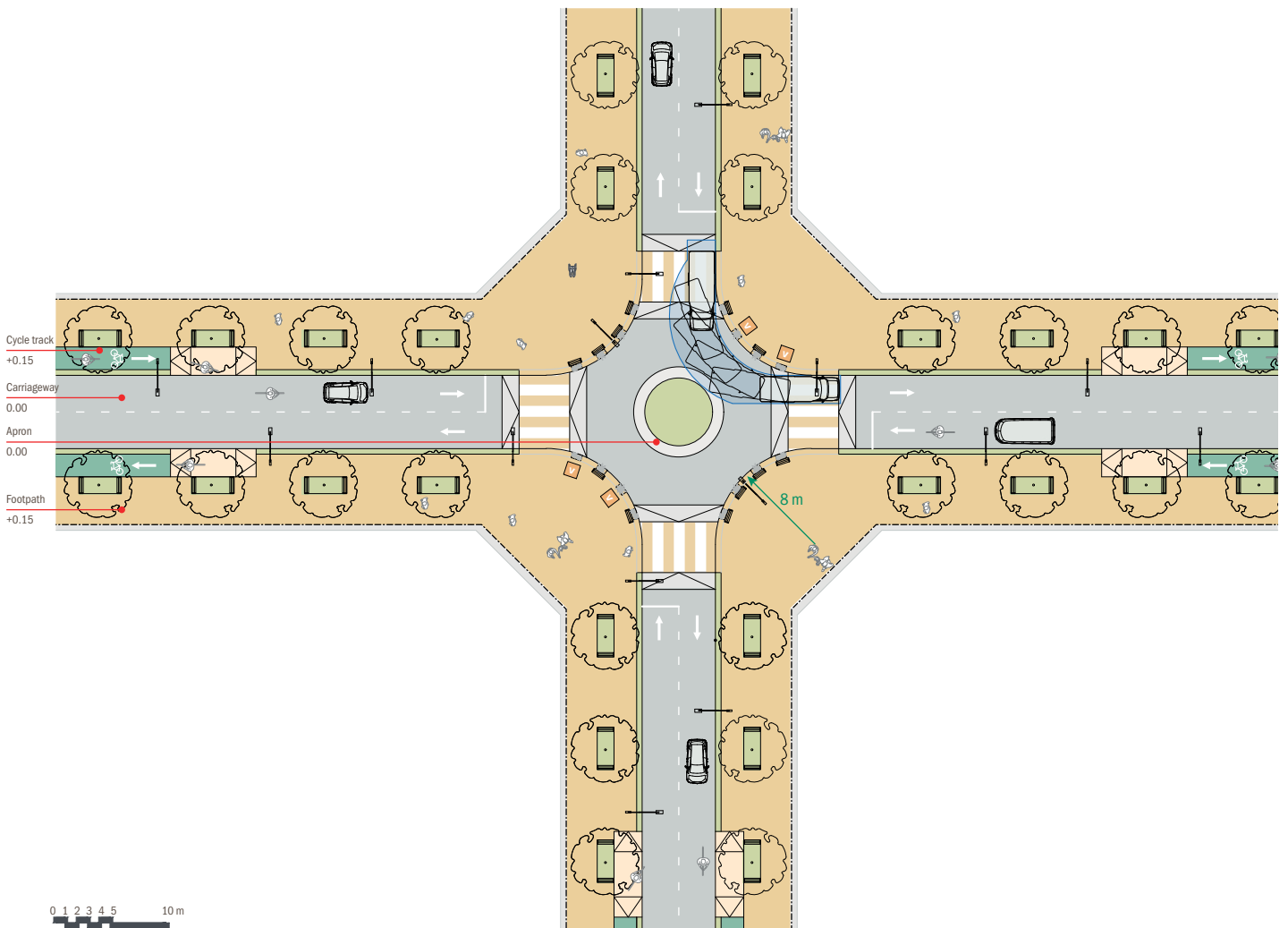

Four-way intersection

20 m x 20 m

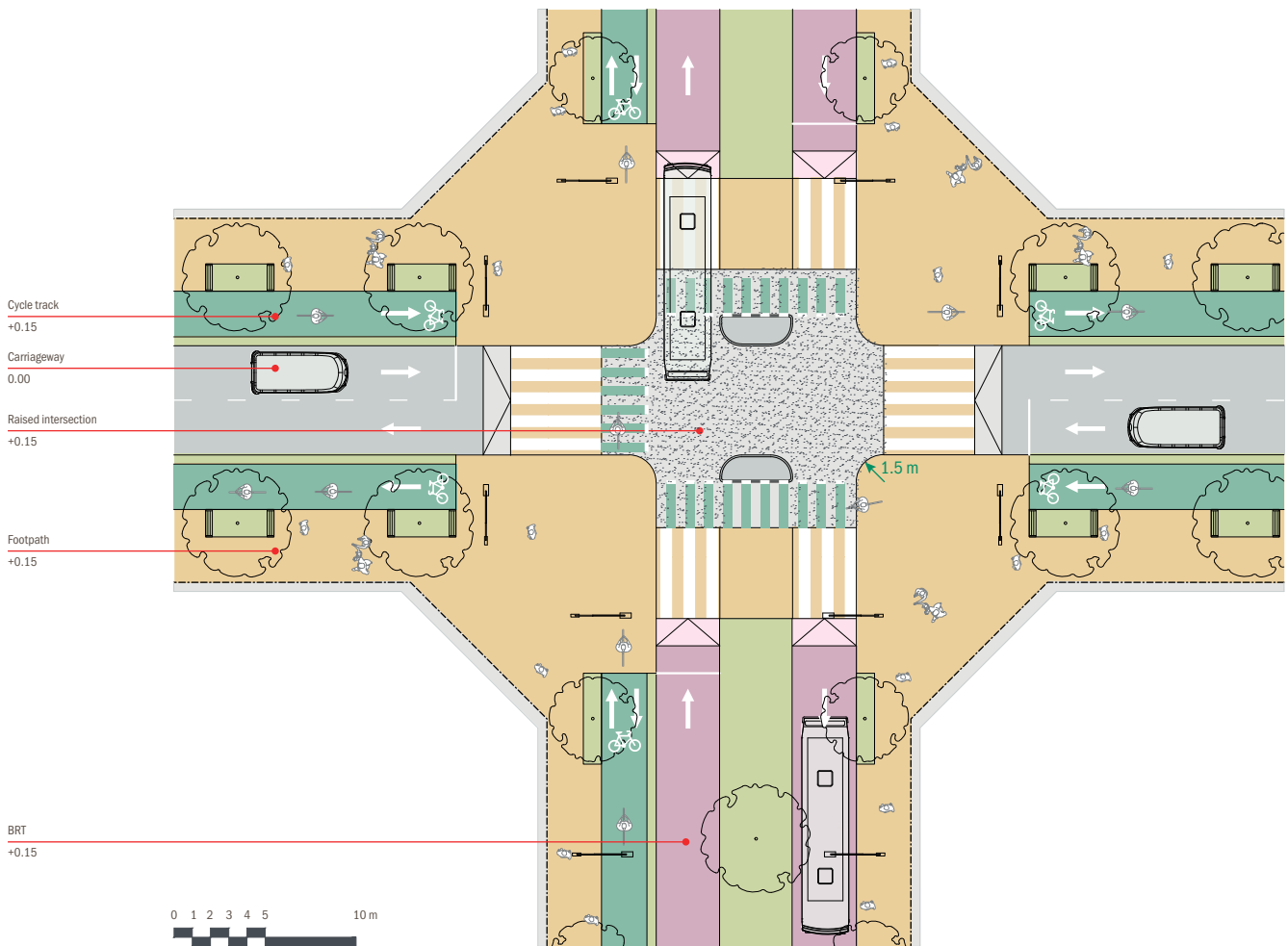

Four-way intersection

30 m x 30 m

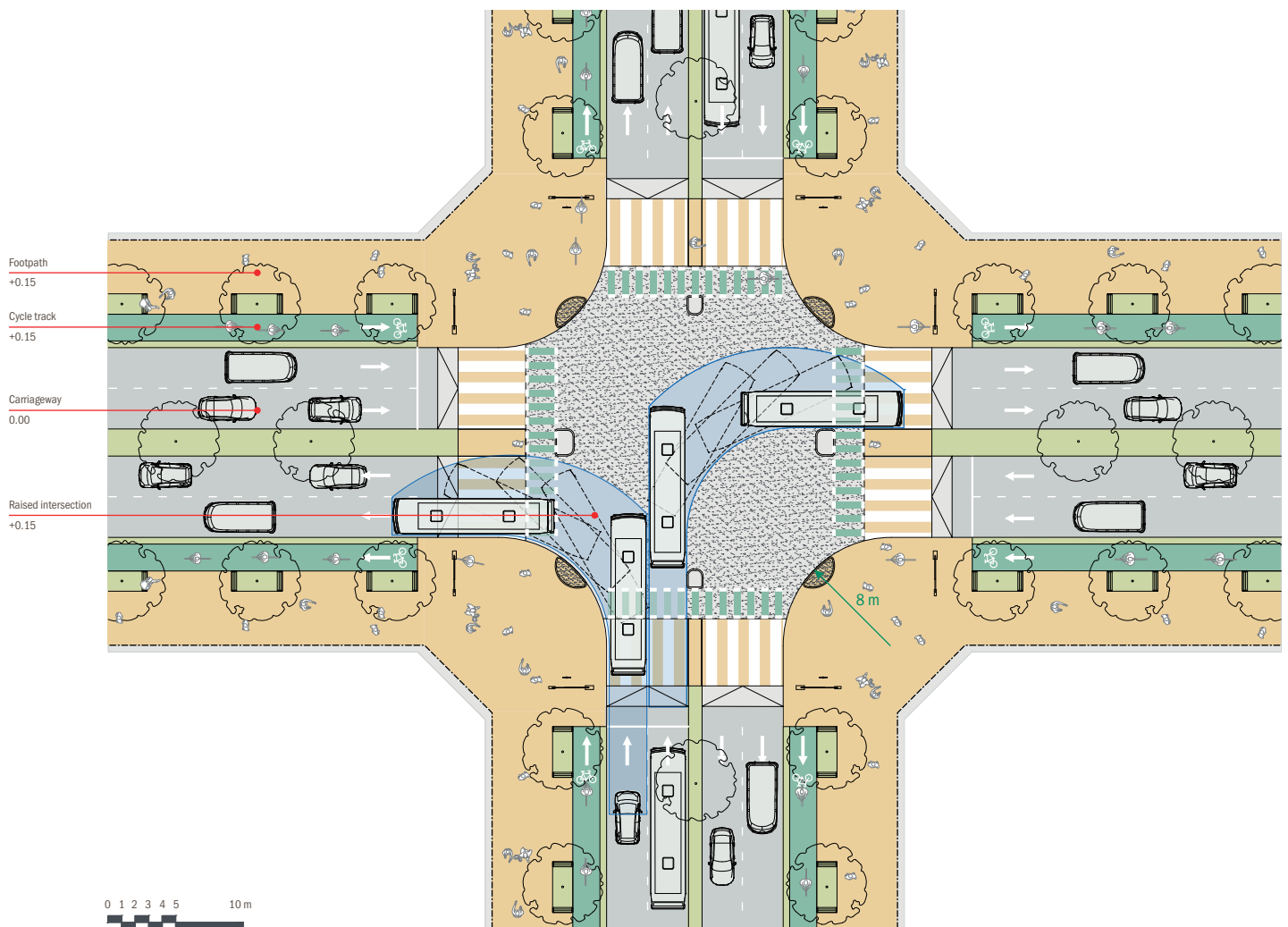

Roundabout (BRT)

30 m x 30 m

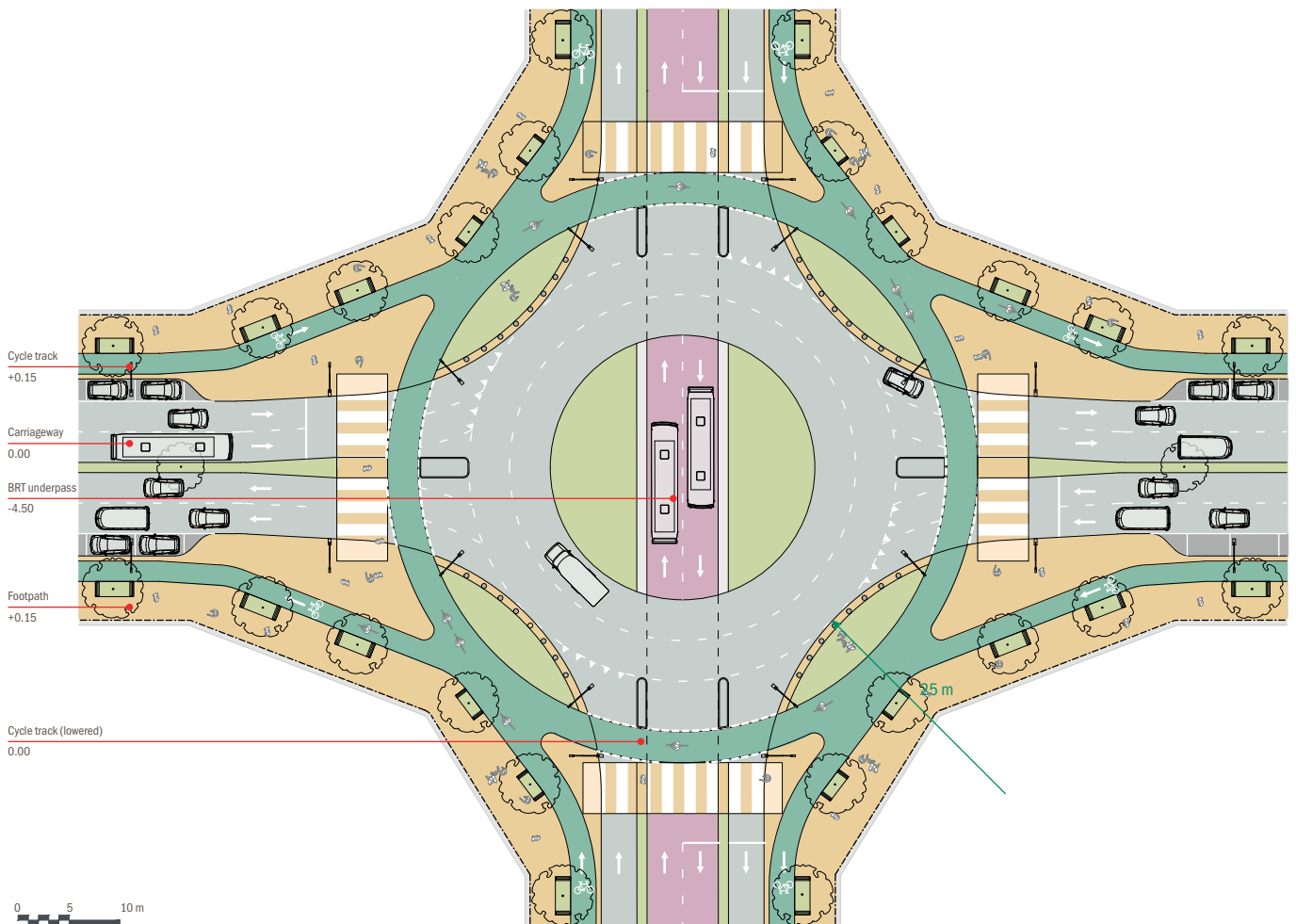

T intersection (BRT)

30 m x 30 m

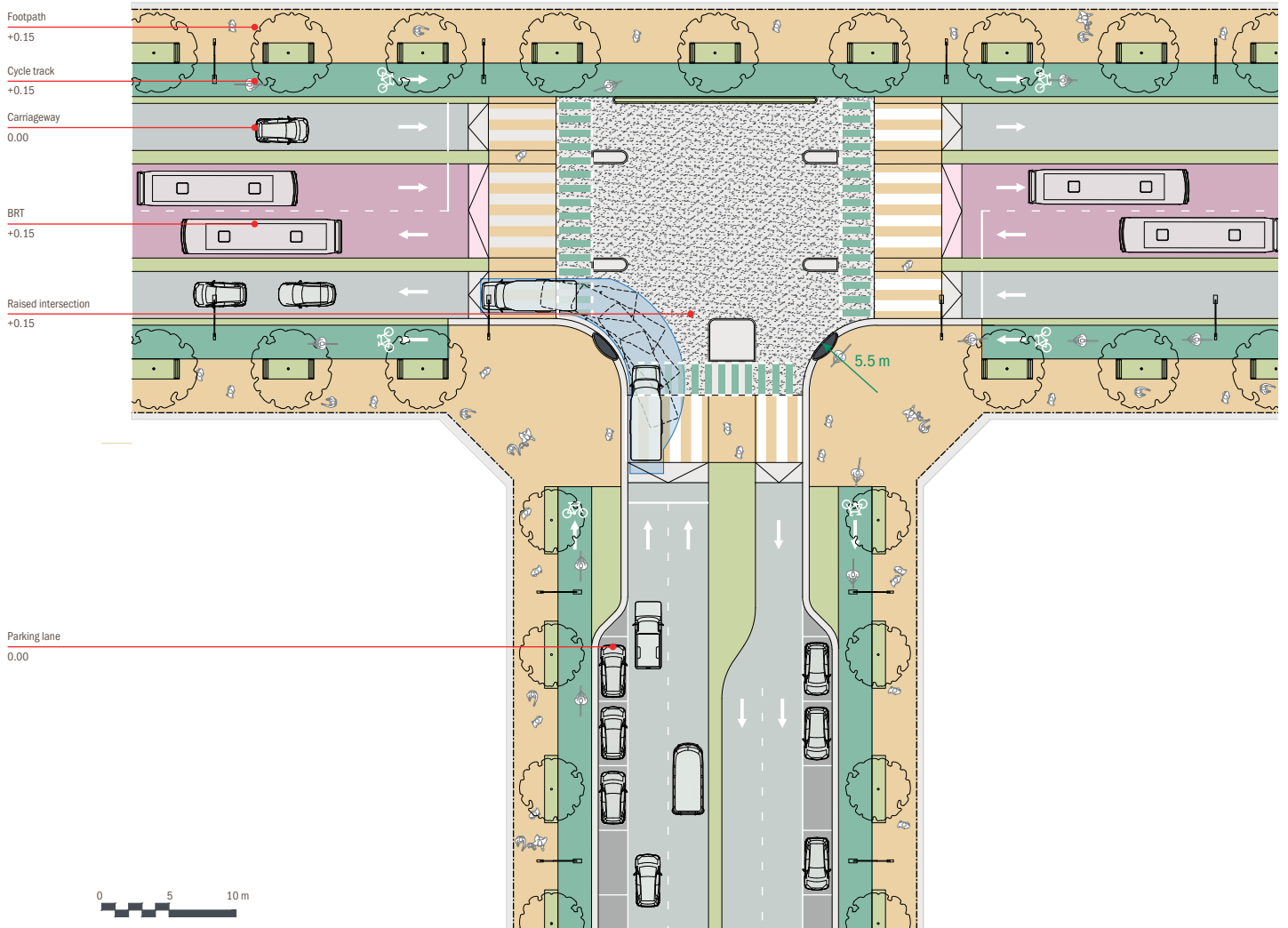

Four-way intersection (BRT)

40 m x 40 m

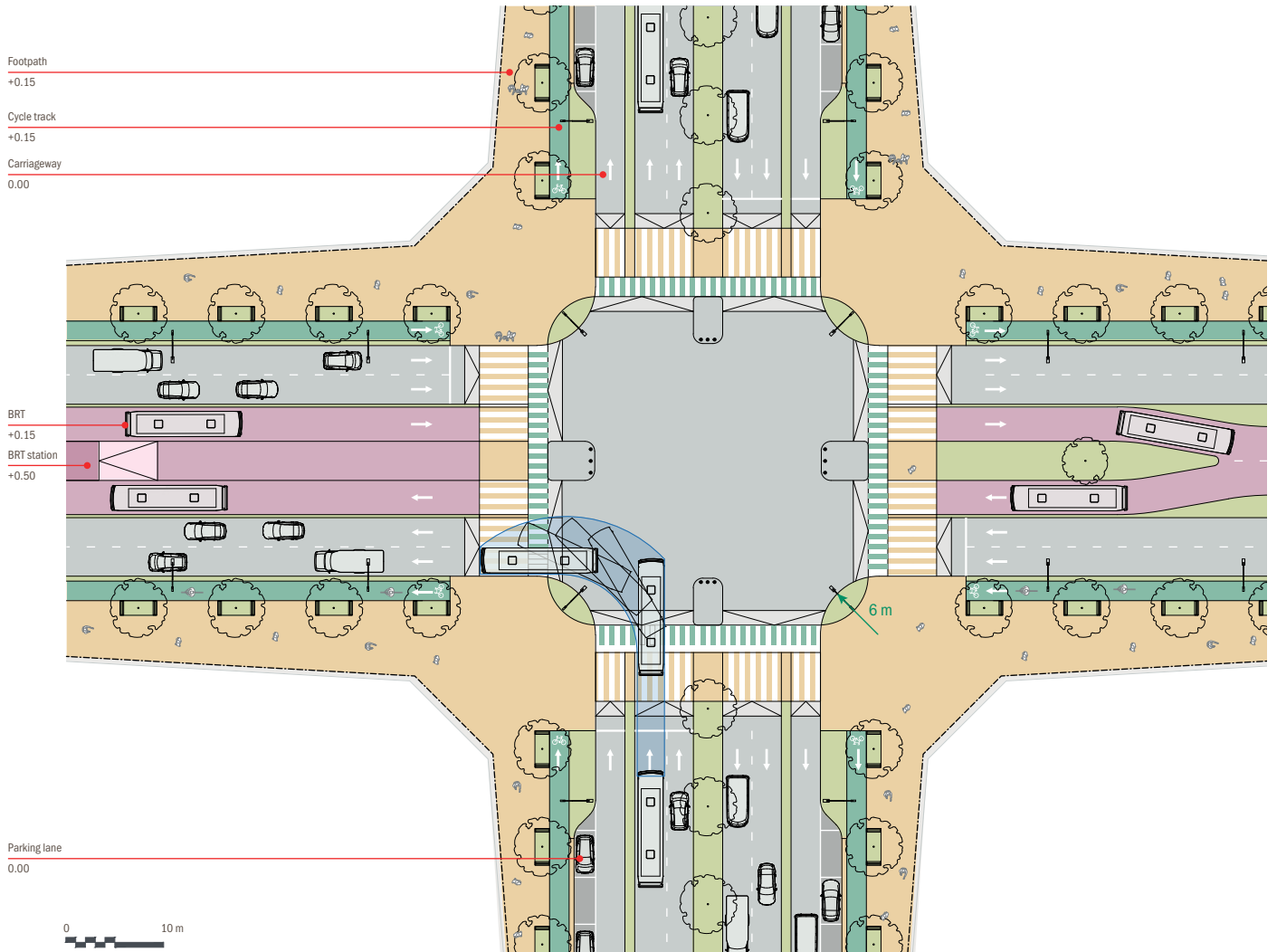

Four-way intersection (BRT, grade-separated)

50 m x 50 m

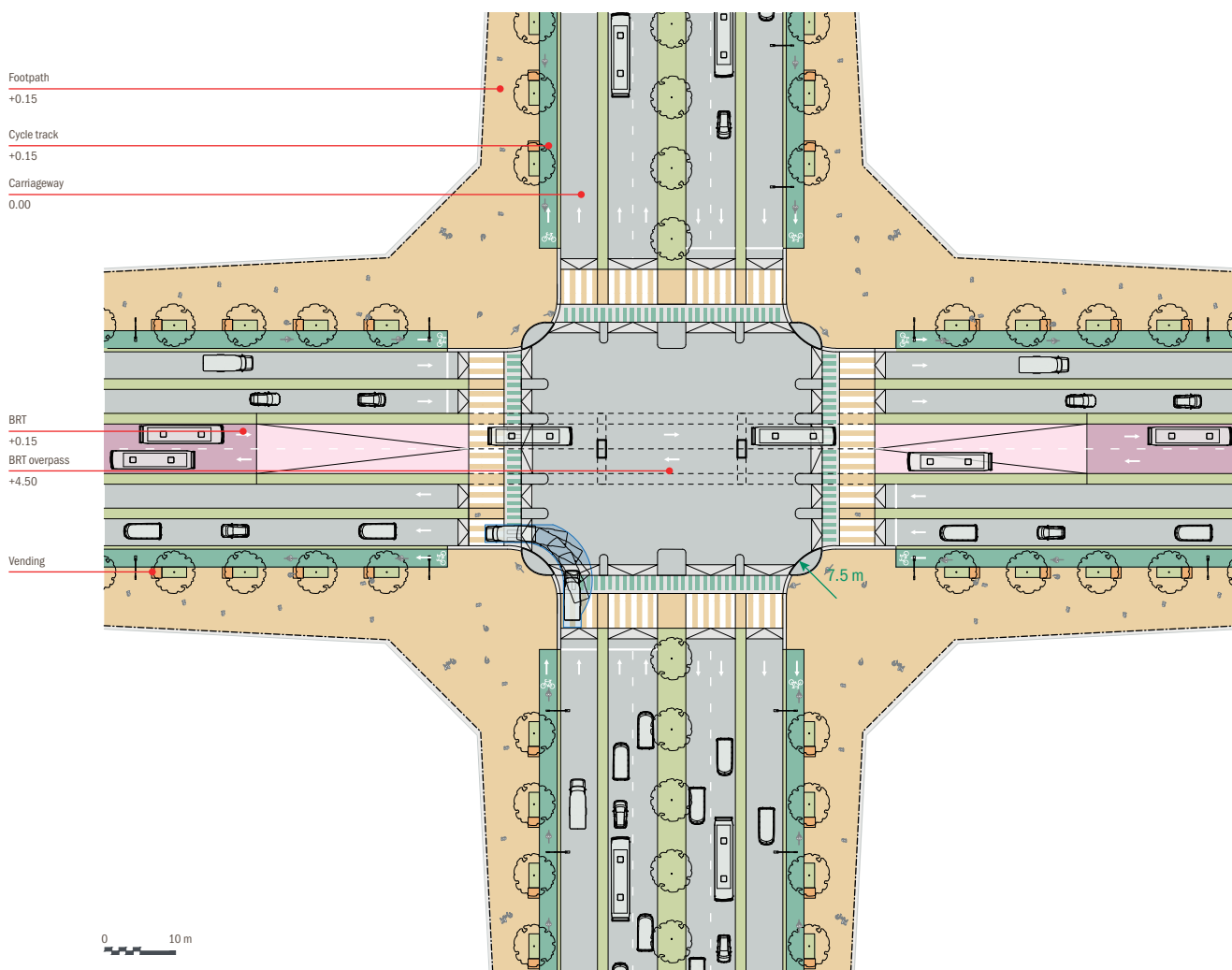

Multi-legged roundabout retrofit (BRT, grade-separated)

40 m x 20 m x 15 m

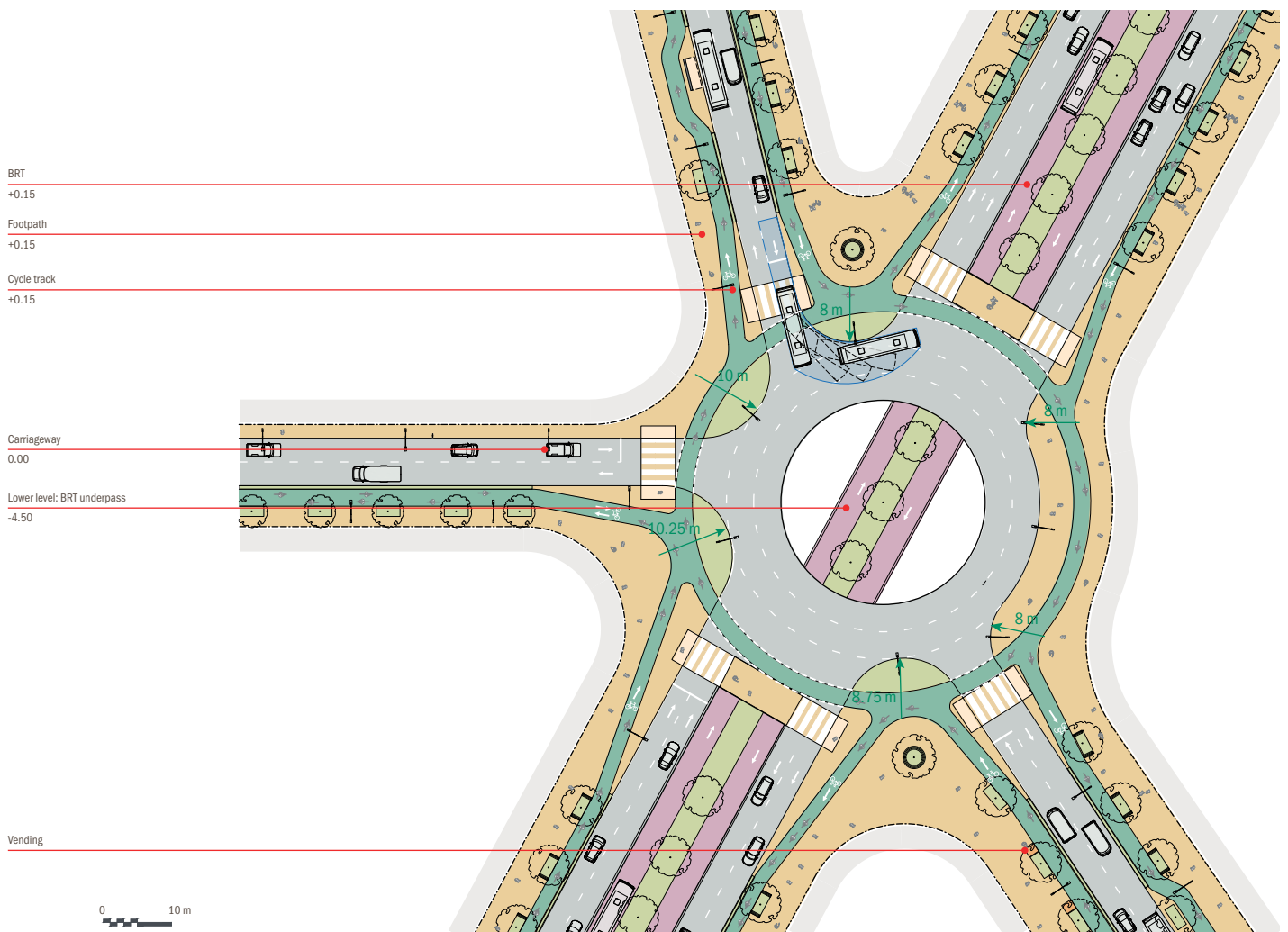



7. DESIGN PROCESS

This chapter describes the process of designing streets in an urban environment. Connectivity and safety are key aspects to consider during the street design process. Creating an effective design involves analysing the existing conditions in the project area, identifying design solutions to suit the local conditions, and working with an interdisciplinary team of professionals to develop an effective design.

The street design process involves the following stages:

1. Project identification and conceptualisation
2. Data and information collection
3. Preliminary designs, cost estimate, and economic evaluation
4. Stakeholder engagement
5. Preliminary designs
6. Design review
7. Detailed designs and final cost estimate
8. Tender documentation

7.1. PROJECT IDENTIFICATION AND CONCEPTUALISATION

At the onset of the design process, it is key that the designer consult relevant government agencies and local stakeholders to understand challenges on the site and to brainstorm on potential solutions.

7.2. DATA AND INFORMATION COLLECTION

The designer should collect primary and secondary information about site conditions, including the following.

Transport and land use plans: Before commencing the design process, the designer should review existing transport and land use plans. The designer should compile spatial information about ongoing and planned transport investments, including bus rapid transit (BRT) networks, cycle networks, pedestrian networks, and pedestrian zones. The designer should identify transport system goals that are stated in these reports.

Topographic survey: The purpose of a topographic survey is to collect data on the project site including all the existing features (see box). The designer should supplement the topographic survey with information on underground utility networks obtained from the client.

TOPOGRAPHIC SURVEY

The topographic survey must cover all streets in the project area plus any intersecting streets up to a distance of 100 m from the intersection with the study area street. The survey should locate the following elements, each geocoded with X, Y, and Z coordinates. Each type of element should be on a different layer in AutoCAD:

- ▶ Main roads, sub-roads, and service lanes, as applicable
- ▶ Signals /road marks
- ▶ Intersection elements
- ▶ Roundabouts
- ▶ Medians / bollards /permanent barricades
- ▶ Compound walls and each access point/ gate
- ▶ All utility (electricity, telephone etc.) poles/boxes

- ▶ Overhead high tension lines
- ▶ Trees: to be indicated in 2 categories: above and below 30 cm of main trunk circumference
- ▶ Front facade of existing buildings/structures
- ▶ Footpaths/pathways including all kerbs and level differences
- ▶ Kerbs
- ▶ Manholes
- ▶ Drains (covered and uncovered)
- ▶ Signboards/markings
- ▶ Service lines/cable ducts
- ▶ The difference in levels wherever it occurs
- ▶ Establishing true/magnetic north point with respect to each location
- ▶ Establishing reduced/relative level for each item

Each map should be georeferenced with latitude, longitude, and height coordinates so that it can be combined with other maps on a GIS platform. Each element should be in a separate layer.



Figure 85. Sample topographic survey drawing.

Survey of land uses: The designer should compile land use information to help inform street design decisions. The survey should document the ground floor and above ground use in every building in the study area. The land use analysis should note important activity generators, such as shopping areas, theatres, and housing developments. All land use data should be recorded using a GIS platform.



Figure 86. Renderings can help stakeholders envision proposed street designs.

Existing NMT condition survey: Key to designing an effective NMT network is to have an in-depth understanding of the existing walking and cycling environment, and the extent to which it provides safe, convenient access for NMT users. Street conditions can be captured using a smartphone application. The app allows a surveyor to record street characteristics and remotely upload the information to an online spreadsheet. The data from these surveys are then cleaned, mapped, and analysed to inform preliminary interventions along the surveyed streets.

Survey of NMT user movements: Information on NMT volumes on each street can help inform the design and sizing of pedestrian and cycle facilities. A range of applications can be used for NMT counts. NMT surveys should be disaggregated by gender, age, and disability.

Traffic counts: Data obtained through a traffic survey are necessary for intersection design and signal timing optimisation. The traffic survey quantifies vehicle and non-motorised user movements. Traffic surveys should be conducted during peak periods when motorised traffic and demand for space are highest. To improve quality control, the preferred method is to collect video recordings and then conduct the enumeration. The count should be categorised by vehicle type. In many cases, classified traffic count data from prior surveys can be obtained from relevant agencies.

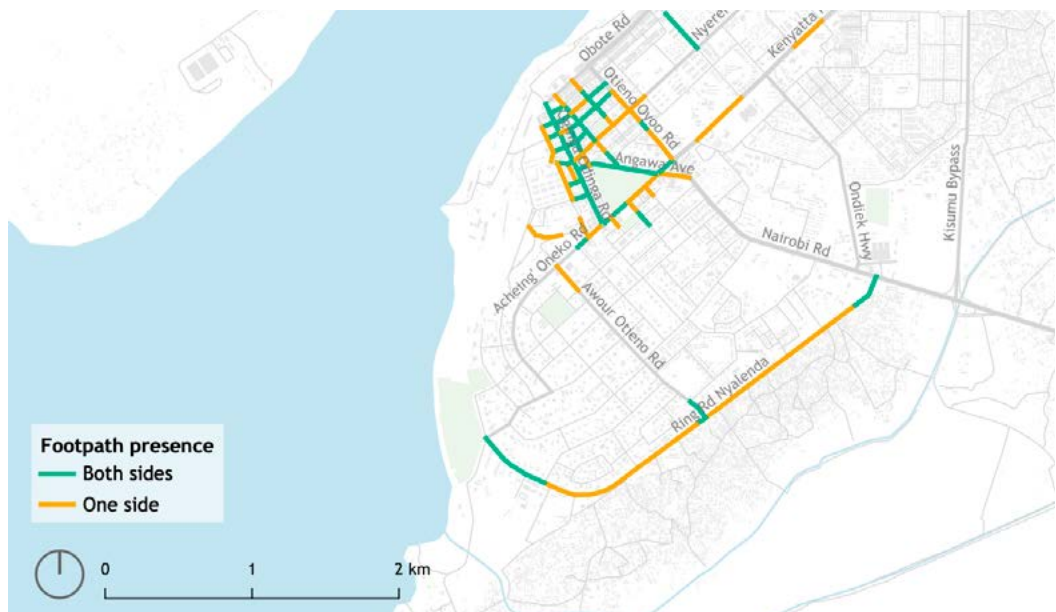

Figure 87. Analysis of footpath presence.

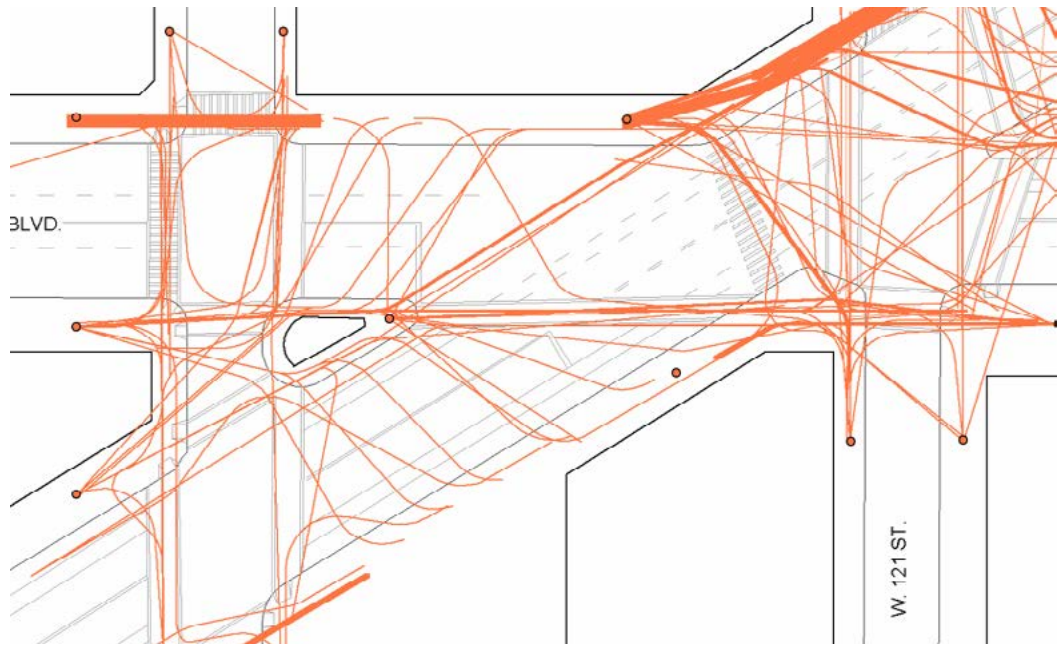

Figure 88. A tracking survey documents pedestrian movements through an intersection.

Parking survey: A parking survey seeks to quantify current parking patterns in the project area by collecting data on the existing parking capacity and demand. Parking often appears crowded and chaotic in some areas, creating the impression of an overall shortage, yet there could be several unused parking spaces within a reasonable walking distance. A parking survey reveals such imbalances, and appropriate measures can be included in the street design to improve parking efficiency on the street. Three types of surveys should be carried out:

- **Parking inventory survey:** The first step involves recording the number of parking spaces in on-street and off-street facilities.

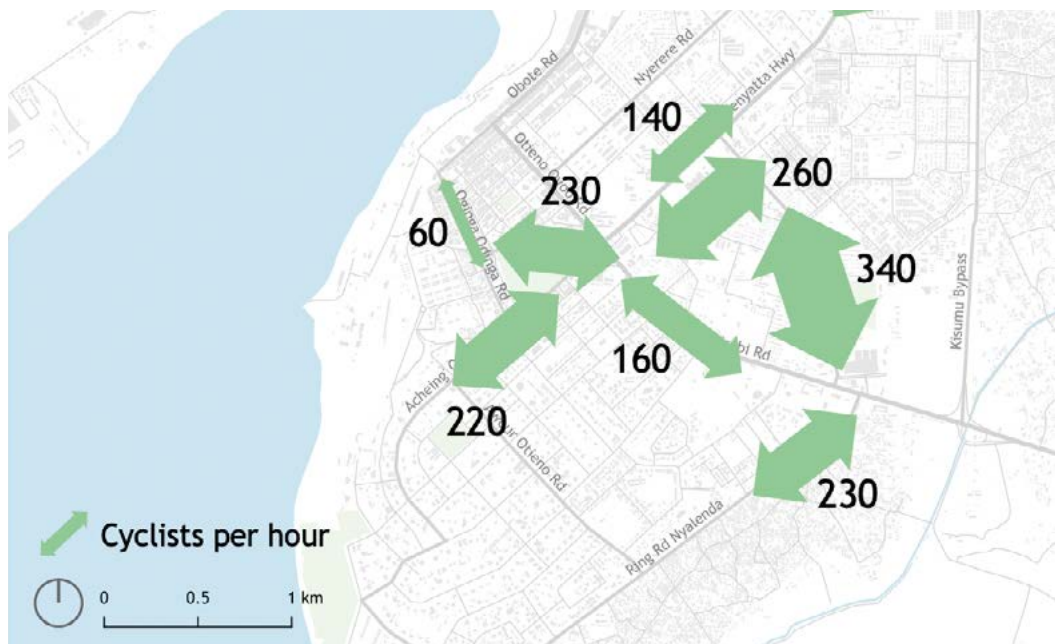

Figure 89. Cycle volume counts.

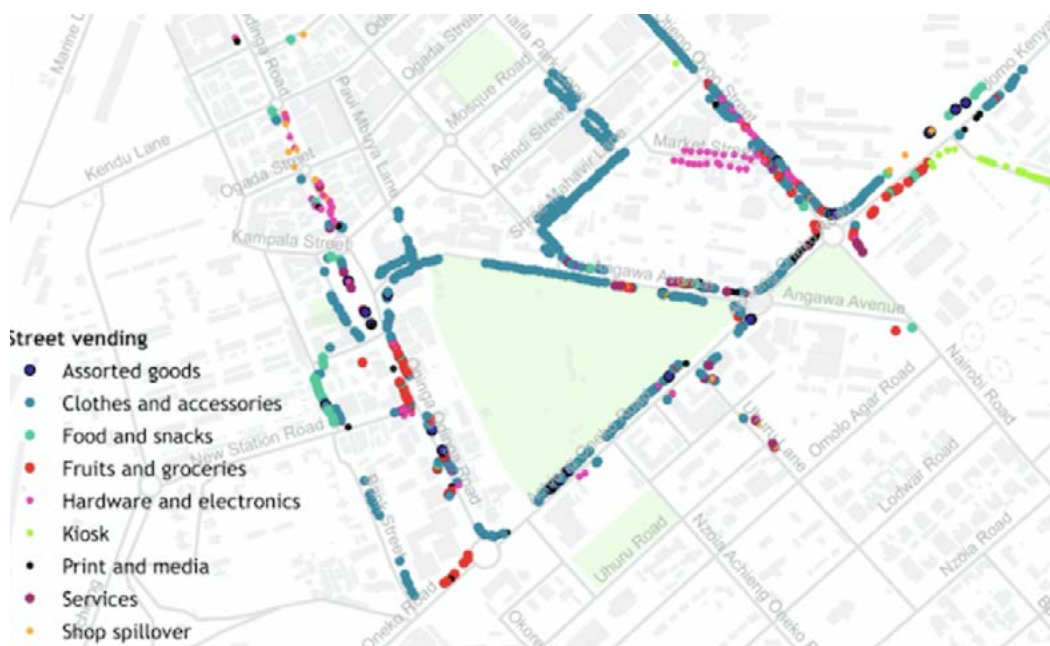

Figure 90. Mapping of street vendors.

- **Occupancy survey:** The second step involves counting the number of vehicles parked on each street segment or off-street parking facility over the course of the day. These counts can be used along with the supply data gathered in the first step to calculate occupancy rates.
- **Turnover survey:** Turnover data can help determine what types of users are parking in a particular facility (e.g., all-day parking by office-goers, short-term parking by shoppers, etc.).

Street vending and related activities survey: The designer must document existing vending activity, including the type of vending and the physical typology of the vending structure (i.e., permanent or temporary structure). The location and characteristics of each vendor should be recorded using GIS. The survey also should capture social gathering spaces in the study area. This information will inform the placement of street furniture and other elements in the final design.

Analysis of crash data: The designer should obtain data on traffic crashes over the past three years. The crash location, type, and users involved (i.e., pedestrian, cyclist, two-wheeler, car, bus, etc.) should be mapped using a GIS platform. This information will enable the designer to identify major traffic safety “black spots” and suggest traffic calming, intersection modifications, and other interventions to improve safety for vulnerable street users.

Right-of-way: The designer should map the available public right-of-way (ROW). County planning departments, the Survey of Kenya, and other relevant authorities may be in a position to provide the ROW of streets in the study area.

Documentation of public transport: To document existing public transport routes and services, data on the public transport services within the project area should be collected and mapped. For Nairobi, Mombasa, and Kisumu the matatu routes have been mapped and the information is available online. All boda boda stands within the project area also should be mapped. The designer should gather additional information on planned public transport projects within the project area from relevant bodies, such as NaMATA.

Utility survey: Any existing utilities within the project area should be identified during the early stages of design. Utility providers may have information on existing utility networks. If utility maps are not available, it may be necessary to conduct surveys to establish the location of specific utility lines and determine whether relocation is necessary. These utilities may include

lines for telecommunication, electricity, natural gas, water, and sewage. Any existing utilities within the project area should be identified during the early stages of design. Discussions with relevant utility providers should be held to agree on any necessary relocations and installation of service ducts. It is advisable to maintain communication with the providers throughout the design and implementation process. The designer should obtain any necessary approvals from utility providers for planned relocations.

7.3. CONCEPT DESIGNS

The designer should prepare detailed street designs for all streets in the project area. The design must be consistent with relevant plans, including plans for BRT networks, cycling networks, pedestrian networks, and pedestrian zones.

Information on land uses in the project area and NMT user flows will inform the designer's decisions on the width of footpaths, location and sizing of pedestrian crossings, and other design elements. Intersection designs and the width of the lanes should facilitate speed control for motorised traffic to enhance NMT user safety. Cycle tracks should be provided along axes identified in the city's cycle network plan. Facilities such as stations, bus stops, terminals, and other facilities needed to support projected public transport demand should be included in the designs.

Once typical cross sections are assigned, the various street elements should be captured in a concept layout plan. All street elements should be included in the conceptual plan, including public transport, pedestrian facilities, cycle tracks, bus stops, BRT stations (if applicable), mixed traffic lanes, vending kiosks, and landscaping. The concept design should be discussed with the city/county management and relevant agencies for concurrence.

DESIGN TEAM COMPOSITION

Preparation of effective designs for urban streets requires collaboration among an interdisciplinary team of professionals. A design team should include the following roles:

- ▶ **Project lead/manager:** Master's degree in transport planning, landscape architecture, civil/transport engineering, or urban design. At least 5 years of experience in street/NMT improvement projects, project management, and contract administration.
- ▶ **Landscape architect/architect/urban designer:** Degree in architecture, urban design, landscape architecture, or equivalent field. At least 3 years of experience in urban street/NMT improvement projects.

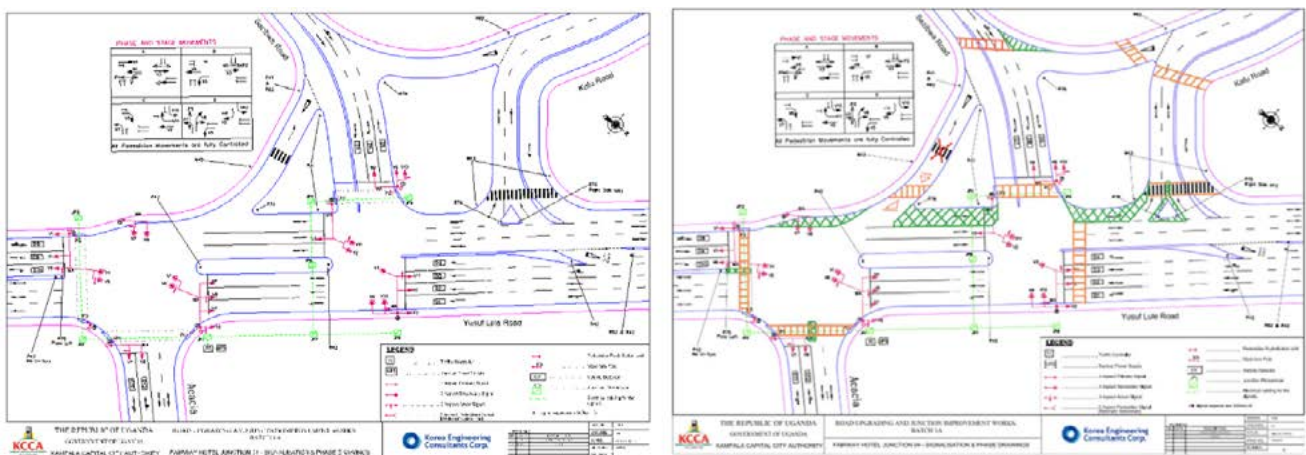

Figure 91. Existing design (left) and conceptual design (right) for NMT improvements.

- ▶ Urban planner: Degree in city planning, landscape architecture, or equivalent field with at least 3 years of experience in urban street/NMT improvement projects.
- ▶ Civil engineer/transport engineer: Degree in civil/transport engineering or equivalent field. At least 3 years of experience in urban street/NMT improvement projects.
- ▶ Land surveyor: Degree in land surveying or equivalent field. At least 3 years of experience in topographic surveys for street projects.

Travel demand forecasting

Traffic forecasts used to inform street improvement projects often overestimate traffic growth based on an assumption that future growth in the use of private motor vehicles is inevitable. However, urban travel demand patterns can be influenced through transport policies and investments. Public transport improvements, high-quality walking and cycling facilities, and parking management measures can all help to encourage a shift from personal vehicles to sustainable modes, thereby offsetting future growth in traffic volumes.

Travel demand forecasts should consider the following factors:

- **Population growth:** Estimates of future population growth are available in county integrated development plans, spatial plans, or from the Kenya National Bureau of Statistics.
- **Trip rate:** The number of daily trips per capita is typically derived from household survey data and can be found in master plans or transport studies. The trip rate typically increases over time as incomes rise but is also affected by changing labour patterns, such as work-from-home arrangements.
- **Mode split:** Existing and future mode splits can be found in the urban mobility plan or spatial plan for the respective urban area.

Improvements in public transport and NMT facilities, a reduction in trip lengths due to transit-oriented development, and travel demand measures can all contribute to a reduction in the mode share for personal motor vehicles. Changes in the mode split can offset possible increases in travel resulting from growth in population and incomes.

The methodology for calculating the traffic growth is as follows:

1. Determine the initial traffic volume for each traffic class, c , using the results of the traffic survey and any other recent traffic count information.
2. Estimate the annual growth rate, i , expressed as a decimal fraction. The growth rate will be influenced by the following factors:
 - Population growth
 - Trip rate
 - Mode shift changes, as outlined in the respective master plan
3. For each transport mode, estimate the traffic in the opening year of the project, using the following formula:

$$AADT_{c,n} = AADT_{c,0} \times (1+i)^n$$

4. Combine the volumes for each transport mode to determine the overall volume.

Example: Kisumu travel demand. The population of Kisumu is expected to increase from 568,000 to 770,000 by 2030, a 2.3 percent annual increase. Meanwhile, the Kisumu Sustainable Mobility Plan (KSMP) calls for an increase in the share of trips by walking, cycling, and public transport as shown in the table below.

Table 10. Modal split under mobility scenarios for Kisumu. (Source: KSMP)

Mode	Today	2030, KSMP sustainable scenario
Walk	52.7%	54.0%
Bicycle	3.4%	7.0%
Bicycle boda	1.5%	1.5%
Matatu/bus	13.0%	16.0%
Tuk-tuk	3.4%	2.0%
Motorcycle boda	13.5%	10.0%
Motorcycle	5.8%	4.3%
Car	5.6%	4.1%
Other	1.1%	1.1%

The per capita trip rate is expected to increase at a rate of 0.5% per year. Due to growth in population and in the per capita trip rate, total daily trips are expected to increase as shown in the table below. However, the KSMP calls for improving facilities for walking, cycling, and public transport in order to absorb the growing demand for travel without an increase in the number of personal motor vehicle trips.

Table 11. Daily trips in Kisumu. (Source: KSMP)

Mode	Today	2030, KSMP sustainable scenario
Walk	437,513	608,181
Bicycle	28,227	78,838
Bicycle boda	12,453	16,894
Matatu/bus	107,926	180,202
Tuk-tuk	28,227	22,525
Motorcycle boda	112,076	112,626
Motorcycle	48,151	48,429
Car	46,491	46,177
Other	9,132	12,389

The resulting growth rates through 2030 are as follows:

- Total trips: 2.8 percent per year
- NMT trips: 3.6 percent per year
- Public transport: 2.2 percent per year
- Private modes: 0.0 percent per year

These growth rates can be applied to traffic counts to determine future traffic volumes.

7.4. STAKEHOLDER ENGAGEMENT

Public participation is a requirement under the Constitution of Kenya, 2010, aimed at promoting transparency in decision making. Public participation is, therefore, a key step in the street design process. The project team should inform the stakeholders of the planned developments and to seek their input into the designs. It is important to engage all key stakeholders including:

- National ministry responsible for transport
- County and/or city/urban area roads and transport department
- County and/or city/urban area planning department
- Local transport authorities
- National roads authorities
- National authority responsible for road safety
- Environmental management authority
- Public transport operators
- Street vendor representatives
- Business community
- Persons with disabilities
- Gender based organisations
- Donor agencies and development partners
- NGOs and civil society organisations in transport and related sectors
- Utility providers (e.g., water, electricity, telecommunications)
- Cycling community

7.5. PRELIMINARY DESIGNS, COST ESTIMATE, AND ECONOMIC EVALUATION

After gathering feedback on the concept designs, the designer prepares preliminary designs reflecting the stakeholder inputs. The designer also prepares a preliminary cost estimate and economic evaluation.

7.6. DESIGN REVIEW

For quality control and to ensure that the standards outlined in this manual are achieved in the design, the concept street designs should be submitted to the county transport director or road agency design manager, who will share the designs with members of a review committee for comments. Preliminary designs will be reviewed by the committee to confirm that they are aligned with city goals, street design principles, and design standards outlined in this manual. Street design review committees should be comprised of the following members:

- County transport department representative
- County architect
- County landscape architect
- County planning department representative
- Regional manager from roads authority (as applicable)
- Regional manager from safety authority
- City transport authority (as applicable)
- County environment department representative

The designer may be required to present the plans at additional public stakeholder meetings. The designer should revise the preliminary design based on the feedback received from the review committee and other stakeholders.

7.7. DETAILED DESIGNS & FINAL COST ESTIMATE

Following approval by the client of the preliminary designs, the designer will prepare detailed construction drawings and a final cost estimate. The designs should include geometric and vertical profiles and should incorporate drainage designs. The final working drawings must be submitted to the client for approval.

7.8. TENDER DOCUMENTATION

The final stage of the process is to prepare specifications, bills of quantities (BOQ), and bid documents for the implementation of the proposed street improvements, including pavements, furniture, street lighting, landscaping, and other components. The designer should work with the client to include appropriate mechanisms in the bid documents to facilitate long-term maintenance, such as annuity-based compensation of contractors. Maintenance provisions must cover all street elements, including walkways, cycle tracks, furniture, trees, lighting, and drainage.

To achieve complete street designs, the BOQ should incorporate the following items that are not conventionally included in street improvement BOQs:

- Footpaths
- Tabletop pedestrian crossings
- Cycle tracks
- Trees and other landscaping elements
- Bus stops and bus shelters
- Street furniture, including seating and trash receptacles
- Street lights
- Bicycle parking
- Public toilets

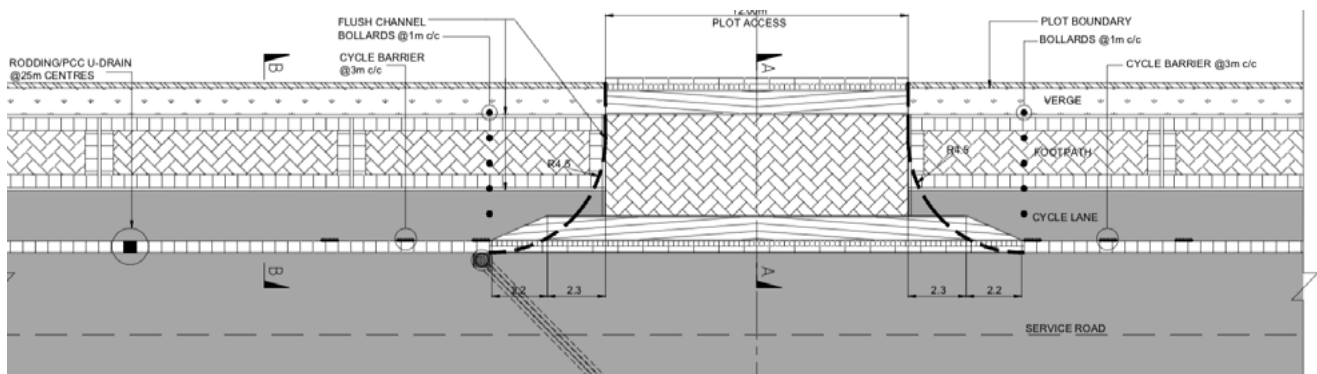

Figure 92. The designs and BOQ should include provision for pedestrian elements such as tabletop crossings.

8. DESIGN CHECKLIST

Element	Design criteria
Footpath	<ul style="list-style-type: none"> • Height of 150 mm above the carriageway. • Minimum 2 m clear width in all locations. • Wheelchair kerb ramps have a maximum slope of 1:10 (1:12 preferred). • Bollards installed along the edge of the footpath to prevent driving and parking on the footpath. • At least one set of bollards with spacing of 900 mm. • The footpath surface is uniform and non-slippery, with slope of 1:50 to avoid water stagnation. • Tactile warning are strips located at transition points (e.g., mid-block crossings, intersections).
Cycle track	<ul style="list-style-type: none"> • Physically separated from the carriageway. • Elevated 150 mm above the carriageway. • Minimum 2 m clear width for one-way movement, and 3.0 m for two-way movement.
Property entrances	<ul style="list-style-type: none"> • The footpath remains at the same level through property entrances. • Bollards are installed on either side of each entrance to prevent driving and parking. • Property access is provided at a discrete location for each plot, with a maximum entrance width of 6 m for residences. For commercial facilities, queuing space is provided inside the property.
Mid-block crossings	<ul style="list-style-type: none"> • Pedestrian crossings at regular intervals, depending on demand. • Crossings raised to the level of the footpath with ramps for vehicles (minimum slope of 1:8) OR kerb ramps at each end of the crossing if signal control is provided. • Median refuge island with minimum dimension of 1.5 m x 3.0 m.
Intersections	<ul style="list-style-type: none"> • Kerb ramps on all corners of intersections to provide wheelchair access to the footpath. • Median refuge island with minimum dimension of 1.5 m x 3.0 m on all legs with more than two lanes to cross. • Signalisation if any leg has more than 2 lanes to cross. • Pedestrian crossings located along desire lines. • Turning radii are no more than 3 m at minor streets, 8 m at locations with turns into a single lane, and 5 m for turns into more than one lane.
Shade	<ul style="list-style-type: none"> • Tree pits every 10 m.
Lighting	<ul style="list-style-type: none"> • No dark spots on footpaths, cycle tracks, or carriageway.
On-street parking	<ul style="list-style-type: none"> • Parking is provided in parallel orientation rather than angled or perpendicular parking. • Car parking bay size is no more than 5.0 m x 2.2 m.
Street vending	<ul style="list-style-type: none"> • The design includes designated spaces for organised street vending.

9. DEFINITIONS

Access: Ability to reach social and economic opportunities, measured in terms of the time, money, comfort, and safety that is associated with reaching such opportunities.

Bus rapid transit (BRT): High quality bus-based mass rapid transit system that delivers fast, comfortable, reliable, and cost-effective urban mobility through the provision of segregated right-of-way infrastructure, rapid and frequent operations, and excellence in marketing and customer service.

Complete streets: Streets that are designed for all users, including pedestrians, cyclists, public transport passengers, and personal motor vehicles, as well as street vending, trees, street furniture, and other elements.

Greenway: A waterway or strip of land with exclusive facilities for cycling and walking.

Mass rapid transit (MRT): A high quality public transport system characterised by high capacity, comfort, overall attractiveness, use of technology in passenger information systems, and ensuring reliability using dedicated right of way for transit vehicles (i.e., rail tracks or bus lanes).

Mobility: Conditions under which an individual is capable of moving in the urban environment.

Mode share: The share of total trips carried out by a particular mode of urban transport, including walking, cycling, bus, paratransit, rail, two-wheeler, or car.

Non-motorised transport (NMT): Human-powered transport such as walking and cycling.

On-street parking: The space occupied by vehicles to park along the edge of the street.

Paratransit: Service operated by the private sector on a shared or per seat basis along informally organised routes with intermediate stops. The service may or may not have a

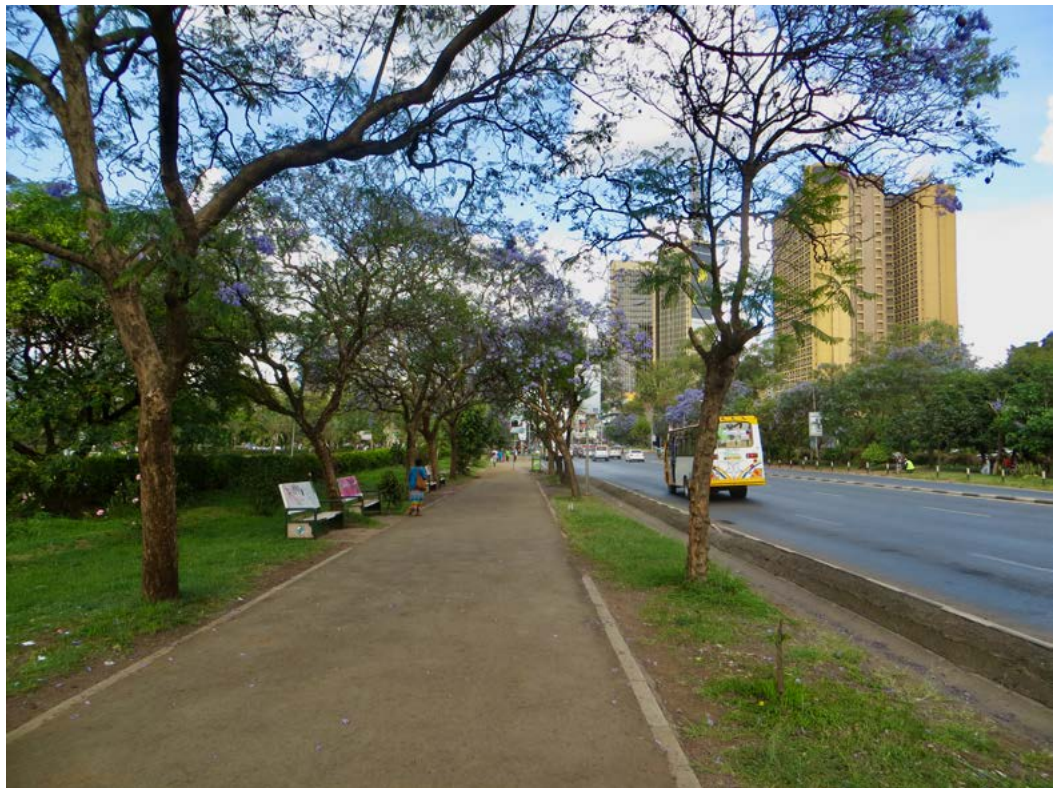

Figure 93. Wide footpath with a dual tree line.

predefined fare structure. The term “intermediate public transport (IPT)” means the same but is avoided in this document for consistency. Common paratransit modes include matatus and shared tuk tuks.

Public transport (PT): Shared passenger vehicles that are publicly available for multiple users. In this document, the term “public transport” is used to refer to MRT, paratransit, and formal road-based public transport services.

Parking management: Pricing, enforcement, and other mechanisms used to guide parking operations to ensure the efficient use of street space.

Right-of-way (ROW): The width of the street, taken from the compound wall/property edge on one side of the street to the compound wall/property edge on the other side of the street.

School zone: All streets and greenways within a 200 m radius of a school.

Sustainable transport modes: Compared with personal motor vehicles, sustainable transport modes consume the least amount of street space and fuel per person-km and also entail lower infrastructure costs: walking, cycling, and public transport (including a regular bus service as well as MRT systems).

Traffic calming: Traffic calming measures ensure pedestrian and vehicle safety by reducing at least speed and potentially also the volume of motor vehicles. Traffic calming slows down vehicles through vertical displacement, horizontal displacement, real or perceived narrowing of carriageway, material/colour changes that signal conflict points, or the complete closure of a street.

Vehicle kilometres travelled (VKT): Vehicle kilometres travelled by all the personal motor vehicles (in a city) in one day.

WWW.ITDP.ORG
WWW.UNHABITAT.ORG

